

# MARINE BIOLOGICAL LABORATORY.

---

Received 21 Dec ' 7

Accession No. 41987

Given by Lew S. Feibiger

Place, Philadelphia

---

\*\*No book or pamphlet is to be removed from the Laboratory without the permission of the Trustees.

MBL/WHOI



0 0301 0021119 9









PLATE I



LOUIS PASTEUR

The greatest of the pioneers in Bacteriology



THE FUNDAMENTALS  
OF  
BACTERIOLOGY

BY  
CHARLES BRADFIELD MORREY, B.A., M.D.

PROFESSOR OF BACTERIOLOGY AND CHAIRMAN OF THE DEPARTMENT IN THE  
OHIO STATE UNIVERSITY, COLUMBUS, OHIO

ILLUSTRATED WITH 175 ENGRAVINGS AND 6 PLATES

*FOURTH EDITION, THOROUGHLY REVISED*



LEA & FEBIGER  
PHILADELPHIA

COPYRIGHT  
LEA & FEBIGER  
1929

PRINTED IN U. S. A.

TO  
GRACE HAMILTON MORREY  
AMERICAN PIANIST





## PREFACE TO THE FOURTH EDITION.

---

AN experience of nearly thirty years in the teaching of Bacteriology has convinced the author that students of this subject need a comprehensive grasp of the entire field and special training in fundamental technic before specializing in any particular line of work. Courses at the University are arranged on this basis. One quarter is devoted to General Bacteriology. During the second and third quarters the student has a choice of special work in Pathogenic, Dairy, Soil, Water, or Chemical Bacteriology. A second year may be devoted to advanced work in any of the above lines, to Immunity and Serum Therapy or to Pathogenic Protozoa.

This text-book is intended to cover the first or introductory quarter's work, and requires two classroom periods per week. Each student is compelled to take three laboratory periods of three hours each per week along with the class work. The outline of the laboratory work is given at the end of the text. Results attained seem to justify this plan. A text-book is but one of many pedagogical mechanisms and is not intended to be an encyclopedia of the subject.

During the preparation of this work the author has made a thorough review of the literature of Bacteriology, covering the standard text-books as well as works of reference and the leading periodicals dealing with the subject. Thus the latest information has been incorporated.

No attempt has been made to give detailed references in a work of this character.

The photomicrographs are original except where otherwise indicated and are all of a magnification of one thousand diameters where no statement to the contrary appears. These photographs were made with a Bausch & Lomb Projection Microscope fitted with a home-made camera box. Direct

current arc light was used and exposures were five to ten seconds. Photographs of cultures are also original with a few indicated exceptions. All temperatures are indicated in degrees centigrade.

For use of electrotypes or for prints furnished the author is indebted to the following: A. P. Barber Creamery Supply Company, Chicago, Ill.; Bausch & Lomb Optical Company, Rochester, N. Y.; Creamery Package Manufacturing Company, Chicago, Ill.; Davis Milk Machinery Company, North Chicago, Ill.; Mr. C. B. Hoover, Superintendent of Sewage Disposal Plant, Columbus, O.; Mr. C. P. Hoover, Superintendent of Water Filtration Plant, Columbus, O.; The Hydraulic Press Manufacturing Company, Mt. Gilead, O.; Loew Manufacturing Company, Cleveland, O.; Metric Metal Works, Erie, Pa.; Sprague Canning Machine Company, Chicago, Ill.; U. S. Marine Hospital Service; Wallace and Tiernan Company, New York City, N. Y.

For the preparation of many cultures and slides, for great assistance in the reading of proof and in the preparation of the index, Miss Vera M. McCoy, Instructor in Bacteriology, deserves the author's thanks.

Exigencies of schedule have required a method of presentation of the subject different from that used with earlier editions. This has resulted in rearrangement of the text-book.

Some of the newer phases of bacteriology which have become prominent since the last edition have been included—the bacteriophage; mutation; life cycles; bacterial growth.

Additions have been made to some portions of the text to make the presentation more clear. A few figures are added and some withdrawn.

Professor Claude E. O'Neal of Ohio Wesleyan University and Miss Florence Belle Darrah of State Teachers College, Oshkosh, Wis., have offered valuable suggestions which are hereby acknowledged. New material and new figures are properly accredited in the appropriate places in the text.

The author trusts that the book will find a place in College and University courses in Bacteriology.

C. B. M.

# CONTENTS.

## CHAPTER I.

### POSITION—RELATIONSHIPS.

Morphology . . . . .	18
Physiology—Metabolism . . . . .	18

## PART I.

### MORPHOLOGY.

#### CHAPTER II.

##### CELL STRUCTURES.

Cytoplasm . . . . .	25
Nucleus . . . . .	26
Vacuoles . . . . .	27
Capsule . . . . .	28
Metachromatic Granules . . . . .	29
Flagellum . . . . .	29
Spores . . . . .	32

#### CHAPTER III.

CELL FORMS . . . . .	37
----------------------	----

#### CHAPTER IV.

CELL GROUPINGS . . . . .	40
--------------------------	----

#### CHAPTER V.

##### CLASSIFICATION.

The Classification of Bergey's Manual of Determinative Bacteriology . . . . .	45
---	----

41987

PART II.  
PHYSIOLOGY.

CHAPTER VI.

GENERAL CONDITION FOR GROWTH.

Occurrence . . . . .	49
Moisture . . . . .	51
Temperature . . . . .	52
Light . . . . .	54
Oxygen Supply . . . . .	56
Osmotic Pressure . . . . .	58
Electricity . . . . .	59
Radiations . . . . .	59
Pressure . . . . .	59
Mechanical Vibration . . . . .	60
High Frequency Vibrations . . . . .	60

CHAPTER VII.

CHEMICAL ENVIRONMENT.

Reaction of Medicine . . . . .	61
Injurious Chemical Substances . . . . .	61
Chemical Composition . . . . .	61

CHAPTER VIII.

CHEMICAL ENVIRONMENT (*Continued*).

General Food Relationships—Metabolism . . . . .	66
Carbon Metabolism . . . . .	68
Oxygen Metabolism . . . . .	69
Nitrogen Metabolism . . . . .	70
Sulphur Metabolism . . . . .	70
Limitation of Growth . . . . .	74
Mutation . . . . .	75
Life Cycles . . . . .	75
Why Cells Divide . . . . .	76
Growth Accessory Substances . . . . .	77

CHAPTER IX.

PHYSIOLOGICAL ACTIVITIES.

Fermentation of Carbohydrates . . . . .	78
Splitting of Fats. . . . .	87



## CHAPTER X.

PHYSIOLOGICAL ACTIVITIES (*Continued*).

Putrefaction of Proteins . . . . .	89
------------------------------------	----

## CHAPTER XI.

PHYSIOLOGICAL ACTIVITIES (*Continued*).

Production of Acids . . . . .	96
Gas Production . . . . .	96
Production of Esters . . . . .	96
Production of "Aromatic" Compounds . . . . .	97
Phosphorescence or Photogenesis . . . . .	97
Production of Pigment or Chromogenesis . . . . .	98
Reducing Actions . . . . .	99
Oxidation . . . . .	100
Production of Heat . . . . .	102
Absorption of Free Nitrogen . . . . .	103
Nitrogen Nutrition of Green Plants . . . . .	105

## CHAPTER XII.

PHYSIOLOGICAL ACTIVITIES (*Continued*).

Production of Enzymes . . . . .	107
Production of Toxins . . . . .	112
Causation of Disease . . . . .	114
Antibody Formation . . . . .	115
Staining . . . . .	115
Cultural Characteristics . . . . .	115

## CHAPTER VIII.

## DISINFECTION—STERILIZATION—DISINFECTANTS.

Physical Agents . . . . .	117
1. Drying . . . . .	117
2. Heat . . . . .	118
Dry Heat . . . . .	119
Moist Heat . . . . .	119
Steam Heat . . . . .	120
3. Cold . . . . .	134
4. Light . . . . .	134
5. Osmotic Pressure . . . . .	135
6. Electricity . . . . .	136
7. Filtration . . . . .	138
8. Burying . . . . .	140

## CHAPTER XIV.

DISINFECTION AND STERILIZATION (*Continued*).

Chemical Agents . . . . .	142
Elements . . . . .	142
Oxygen . . . . .	142
Chlorine . . . . .	143
Compounds . . . . .	144
Calcium Oxide . . . . .	144
Chloride of Lime . . . . .	144
Sodium Hypochlorite . . . . .	144
Bichloride of Mercury . . . . .	144
Organic Compounds . . . . .	145
Carbolic Acid or Phenol . . . . .	145
Cresols . . . . .	145
Alcohol . . . . .	146
Soap . . . . .	146
Formaldehyde . . . . .	146
Anilin Dyes . . . . .	148

## CHAPTER XV.

DISINFECTION AND STERILIZATION (*Continued*).

Choice of Agent . . . . .	149
Standardization of Disinfectants—"Phenol Coefficient" . . . . .	150
Practical Sterilization and Disinfection . . . . .	151

## PART III.

## THE STUDY OF BACTERIA.

## CHAPTER XVI.

## CULTURE MEDIA.

Meat Broth (Bouillon) . . . . .	159
Standardization to a definite H-Ion Concentration . . . . .	161
Titration and Standardization . . . . .	169
Colorimetric Method of Standardization . . . . .	171
Preparation of Standard Colors . . . . .	171

Titration . . . . .	172
Meat Extract Broth . . . . .	172
Glycerin Broth . . . . .	173
Sugar Broths . . . . .	173
Dunham's Peptone Solution . . . . .	173
Nitrate Broth . . . . .	173
Milk . . . . .	173
Litmus Milk . . . . .	174
Gelatin Culture Medium . . . . .	174
Agar Medium . . . . .	175
Potato Media . . . . .	176
Blood Serum Media . . . . .	178

## CHAPTER XVII.

METHODS OF USING CULTURE MEDIA . . . . .	181
--	-----

## CHAPTER XVIII.

ISOLATION OF BACTERIA IN PURE CULTURE . . . . .	191
---	-----

## CHAPTER XIX.

## STUDY OF INDIVIDUAL BACTERIA-STAINING.

Hanging Drop Slide . . . . .	198
Staining . . . . .	201
Anilin Water . . . . .	203
Preparation of the Film . . . . .	204
Gram's Method of Staining . . . . .	205
Staining of Spores in the Rod . . . . .	206
Staining of "Acid-fast" Bacilli . . . . .	206
Gabbet's Method . . . . .	206
Ziehl-Neelson Method . . . . .	207
Staining of Capsules . . . . .	207
Räbiger's Method . . . . .	207
Welch's Method . . . . .	207
Staining of Flagella . . . . .	207
Staining of Metachromatic Granules . . . . .	209
Neisser's Method . . . . .	209

## CHAPTER XX.

STUDY OF THE PHYSIOLOGY OF BACTERIA . . . . .	210
Appearance of Growth on Different Culture Media . . . . .	214

## CHAPTER XXI.

## ANIMAL INOCULATION.

Securing and Transporting Material from Animals for Bacteriological Examination . . . . .	225
---	-----

## PART IV.

## GENERAL PATHOGENIC BACTERIOLOGY.

## CHAPTER XXII.

INTRODUCTION . . . . .	227
------------------------	-----

## CHAPTER XXIII.

PATHOGENIC BACTERIA OUTSIDE THE BODY . . . . .	233
--	-----

## CHAPTER XXIV.

## PATHS OF ENTRANCE OF PATHOGENIC ORGANISMS, OR CHANNELS OF INFECTION.

The Skin . . . . .	239
Mucosæ Directly Continuous with the Skin and Lined with Stratified Epithelium . . . . .	240
Lungs . . . . .	241
Alimentary Tract . . . . .	242
Mechanism of Entrance of Organisms . . . . .	243
Dissemination of Organisms . . . . .	243
Paths of Elimination of Pathogenic Microorganisms . . . . .	243
Specificity of Location of Infective Organisms . . . . .	245

## CHAPTER XXV.

## IMMUNITY.

Active Immunity . . . . .	248
---------------------------	-----

## CHAPTER XXVI.

THEORIES OF IMMUNITY . . . . .	252
--------------------------------	-----

## CHAPTER XXVII.

## RECEPTORS OF THE FIRST ORDER.

Antitoxins—Antienzymes . . . . .	257
----------------------------------	-----

## CHAPTER XXVIII.

## RECEPTORS OF THE SECOND ORDER.

Agglutinins . . . . .	261
Precipitins . . . . .	264

## CHAPTER XXIX.

## RECEPTORS OF THE THIRD ORDER.

Cytolysins . . . . .	267
Amboceptors . . . . .	269
Complements . . . . .	270
Antisnake Venoms . . . . .	272
Failure of Cytolytic Serums . . . . .	272
Complement-fixation Test . . . . .	273
Bacteriophage . . . . .	278

## CHAPTER XXX.

## PHAGOCYTOSIS—OPSONINS.

Bacterial Vaccines . . . . .	281
Lipovaccines . . . . .	283
Aggressins . . . . .	287

## CHAPTER XXXI.

## ANAPHYLAXIS . . . . . 288

A Tabulation of Antigens and Antibodies as at Present Recognized	293
Summary of Immunity as Applied to Protection from Disease .	294

## CHAPTER XXXII.

## A BRIEF HISTORY OF BACTERIOLOGY UP TO 1881.

Spontaneous Generation . . . . .	296
Causation of Disease . . . . .	304
Putrefaction and Fermentation . . . . .	310
Study of Forms . . . . .	312
List of Laboratory Exercises Given in Connection with the Class	
Work Included in this Text-book . . . . .	316





# FUNDAMENTALS OF BACTERIOLOGY.

## CHAPTER I.

### POSITION—RELATIONSHIPS.

THE student in his biological courses has already learned the necessity of classifying living organisms. The division of the organic world into plants and animals is a very old one. It seems to have been based primarily on ability to move from place to place. Animals could move, plants could not. The first microscopic forms discovered in the seventeenth century were called "animalcules," little animals, because many of them could be seen to move. The fact that all organisms are made up of cells and that there are organisms consisting of one cell only was a scientific contribution of the nineteenth century. The term *protista* is used to include all unicellular organisms; *protozoa*, the unicellular animals and *protophyta* the unicellular plants.

In attempting to decide whether a given organism is a protozoon or a protophyton resemblances must be sought between it and other organisms already classified. The decision is based on a *preponderance of resemblances*. There is no one characteristic which is decisive. There are today a number of organisms classified by botanists as plants and by zoölogists as animals because there does not seem to be sufficient evidence for a definite decision. *Euglena*, *myxomycetes* or *mycetozoa*, *spirochetes*, are illustrations.

Resemblances must be sought not alone in *morphology*, the form of the cell, how it looks under the microscope. The *physiology* of the organism must be compared, especially the *method of reproduction* and the *metabolism*. *Chemical composition* is fundamental in metabolism and this must be studied.

If certain aspects of chemical composition are considered, all organisms are found to be alike since all contain the same twelve elements—C, H, O, N, S, P, Cl, K, Ca, Mg, Fe, Mn—and the same classes of compounds, namely, proteins, carbohydrates, fats, mineral salts and water.

In attempting to place the bacteria with their nearest relations they must be compared with other protista in all the characteristics mentioned in the paragraphs above.

**Morphology.**—Bacteria look most like the lowest algæ, the blue-green algæ. A study of Figs. 1 to 7 will show that the forms of the cell are very similar and that the cells are grouped in similar ways. The grouping of the cells shown is the result of their dividing and remaining attached and indicates that both these algæ and the bacteria *reproduce* the same way, that is, by *simple transverse division*. Bacteria are not considered to be algæ because of a fundamental difference in *metabolism* due to the fact that algæ show a marked difference in *chemical composition*. They contain *chlorophyl* and bacteria do not. Chlorophyl is the green-coloring matter which is considered to enable organisms possessing it to utilize sunlight to split up carbon dioxide and build up organic compounds from it.<sup>1</sup> Bacteria with few exceptions (see Chapter VII) are dependent on complex carbon compounds for their carbon and cannot utilize CO<sub>2</sub>.

**Physiology—Metabolism.**—In metabolism the bacteria most closely resemble the fungous or non-chlorophyl plants especially the yeasts and molds. Their chemical composition is also nearest to that of these forms. Another argument for relationship of bacteria to the yeasts is that there are certain organisms which appear to be intermediate between them, transition forms, the *Schizosaccharomyces*, or fission yeasts, Fig. 9. *Such connecting links are good evidence of relationship.*

Bacteria are not yeasts nor are they molds. They differ from both in their manner of reproduction. Bacteria, as has been stated, reproduce by simple transverse division. Yeasts reproduce by budding or gemmation and also by spore formation. The fission yeasts produce spores like the yeasts do and also divide transversely like the bacteria. Molds

<sup>1</sup> See Photosynthesis: Prof. E. C. C. Baly, Science, 1928, 48, 364.



grow as branching threads and form spores in specially developed fruiting organs (Figs. 10 to 16). The higher thread bacteria (Fig. 17) do show branching and rudimentary fruiting organs and are to be considered *connecting links between the true bacteria and the molds*.



FIG. 1.—A thread of blue-green algae.

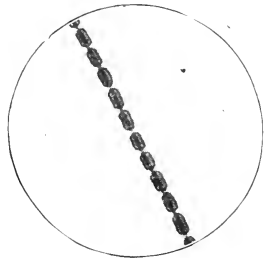

FIG. 2.—A thread of small blue-green algae.



FIG. 3.—A thread of bacteria. Compare with Figs. 1 and 2.

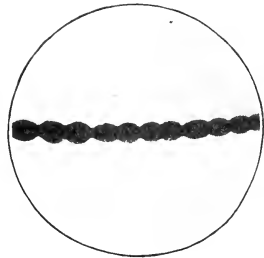

FIG. 4.—A chain of spherical blue-green algae.



FIG. 5.—A chain of spherical bacteria.



FIG. 6.—A pair of spherical blue-green algae.

Some few bacteria, approximately 13 to 14 per cent of all, form spores, but the function of these spores (Chapter II) is markedly different from that of yeasts or mold spores. Bacterial spores are not primarily reproductive, but they correspond more nearly to the *encystment* of many protozoa.

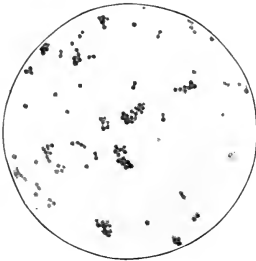

FIG. 7.—Spherical bacteria. Several pairs are shown.



FIG. 8.—Yeast cells. Some show typical budding.



FIG. 9.—Schizosaccharomyces. Yeast-like cells, bacteria-like cells, transverse division are all shown.

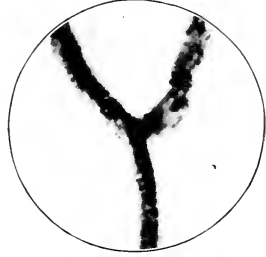

FIG. 10.—A portion of the mycelium of a mold. Note the large size and the branching.

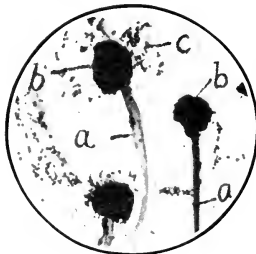

FIG. 11.—Mucor type of mold showing "special fruiting organs."  $\times 100$ .  
a, sporangiophore; b, sporangium; c, free spores.

These protozoa under certain conditions show a change in form, usually to a more or less spherical shape, accompanied by a shrinkage in volume and the development of an outside covering, sometimes largely mineral salts, sometimes more organic. When the protozoön has changed to this form,

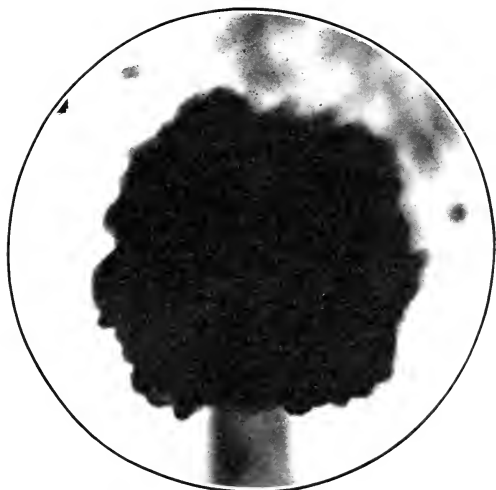

FIG. 12.—Same as Fig. 11.  $\times 1000$ . Shows a sporangium containing a mass of spores.

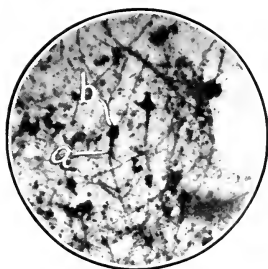

FIG. 13.—Aspergillus type of mold.  $\times 100$ . *a*, conidiophore; *b*, mass of conidia attached to head of conidiophore.

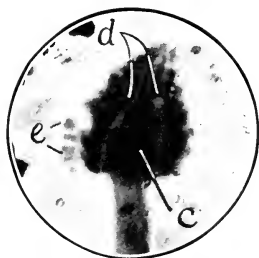

FIG. 14.—Same as Fig. 13.  $\times 1000$ . (Slightly retouched). *c*, enlarged head of conidiophore; *d*, sterigmata; *e*, conidia (spores) at end of sterigmata.

called a *cyst*, it is enabled to withstand much greater environmental changes than the active organism can, especially drying. The bacterial spore resembles these protozoal cysts very closely.

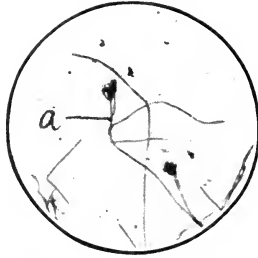

FIG. 15.—*Penicillium* type of mold.  $\times 100$ . *a*, branched conidiophore.

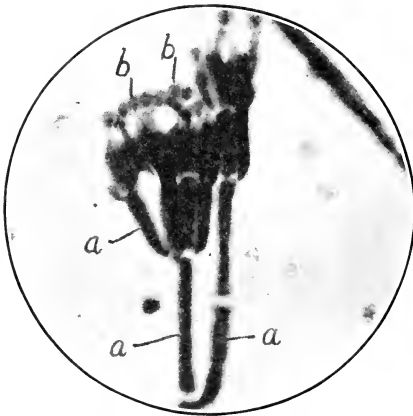

FIG. 16.—Same as Fig. 15.  $\times 1000$ .  
*b*, conidia.

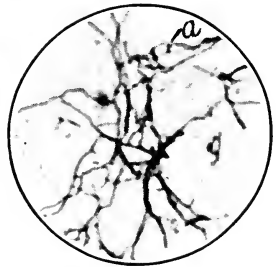

FIG. 17.—Higher bacteria.  
 $\times 1000$ . The fine branching threads are characteristic. *a*, conidium.

Some bacteria have the power of independent motion from place to place in a liquid, they can swim, as many protozoa can. Other low plant forms, as some diatoms and desmids and certain green algæ, also have motility so that this characteristic is not sufficient to place the bacteria with the protozoa, though the motility of bacteria is more like that of the protozoa than that of the protophyta.

The food of bacteria is always taken up in solution by diffusion through the outer covering of the cell, as it is in all plants. Plant cells never surround and engulf particles of solid food and digest them within the cell as many single-celled animals do and as the leukocytes and similar amœboid cells in practically all multicelled animals do.<sup>1</sup>

One of the most generally recognized differences between animals and plants is with respect to their energy relationships. Plants are characteristically storers of energy while animals are liberators of it. Some bacteria which have the power of swimming in a liquid certainly liberate relatively large amounts of energy, and in the changes which bacteria bring about in the material which they use as food considerable heat is evolved ("heating of manure," etc., Chapter XI). Nevertheless, the evidence is good that the bacteria as a class store much more of the energy contained in the substances actually taken into the body cell as food than is liberated in any form.

The above arguments for classifying bacteria may be briefly summarized as follows:

#### RESEMBLANCES TO PLANTS.

1. Like the lowest algae in being single celled, having similar cell forms and similar cell groupings.
2. Like the yeasts in being unicellular and without chlorophyll and having similar metabolism. The fission yeasts form a connecting link.
3. Like the molds in not having chlorophyll and having similar metabolism. The higher bacteria form a connecting link.
4. Chemical composition is similar to fungous plants.
5. Rather storers of energy than liberators of it.
6. Food is always taken into the cell in solution.

#### RESEMBLANCES TO ANIMALS.

1. Like the protozoa in being unicellular.
2. Motility is more like that of certain protozoa than that of protophyta.
3. Spore formation corresponds rather to encystment of the protozoa than to spore formation of fungous plants.

It should be evident that the *preponderance of resemblances* is in favor of placing the bacteria among the plants.

<sup>1</sup> Myxomycetes excepted, and they may just as well be considered animals—Mycetozoa.

Bacteria are among the smallest of organisms, so small that it requires the highest powers of the microscope for their study and the use of a special unit for their measurement. This unit is the one-thousandth part of a millimeter and is called a micro-millimeter or micron. Its symbol is the Greek letter *mu* ( $\mu$ ). The micron, plural microns or micra, is used generally for measuring other microscopic objects as well as bacteria.

The size varies widely among different kinds but is fairly constant in the same kind. The smallest described form is said to be only  $0.18 \mu$  long by  $0.06 \mu$  thick and is just visible with the highest power of the microscope, though it is possible and even probable that there are forms still smaller which cannot be seen. Some large rare forms may measure  $40 \mu$  in length, but the vast majority are from  $1 \mu$  to  $4 \mu$  or  $5 \mu$  long and from one-third to one-half as wide.

From the description outlined in the above paragraphs a bacterium might be said to be a *microscopic, unicellular plant, without chlorophyl, which reproduces by dividing transversely.*

PART I.  
MORPHOLOGY.

---

CHAPTER II.  
CELL STRUCTURES.

THE *essential* structures which may by appropriate means be distinguished in the bacterial cell are *cell wall* and *cell contents*, technically termed *protoplasm*, cytoplasm. The cell wall is not so dense, relatively, as that of green plants, but is thicker than the outer covering of protozoa. It is very similar to the cell wall of other lower fungi. Diffusion takes place readily through it with very little selective action on substances absorbed, as judged by the comparative composition of bacteria and their surrounding medium.

**Cytoplasm.**—The cytoplasm according to Bütschli and others is somewhat different and slightly denser in its outer portion next to the cell wall. This layer is designated the *ectoplasm*, as distinguished from the remainder of the cell contents, the *endoplasm*. When bacteria are suddenly transferred from a given medium into one of decidedly *greater* density, there sometimes results a contraction of the *cytoplasm*, due to the rapid diffusion of water. This phenomenon is designated *plasmolysis* (Fig. 18), and is similar to what occurs in the cells of higher plants when subjected to the same treatment. This is one of the methods which may be used to show the different parts of the cell just described.

If bacteria are suddenly transferred from a relatively dense medium to one which is of decidedly *less* density, it

occasionally happens that water diffuses into the cell and swells up the cytoplasm so much more rapidly than the cell wall that the latter ruptures and some of the cytoplasm exudes in the form of droplets on the surface of the cell wall. This phenomenon is called *plasmoptysis*. Students will seldom observe the distinction between cell wall and cell contents, except that in examining living bacteria the outer portion appears more highly refractive. This is chiefly due to the presence of a cell wall, but is not a proof of its existence.

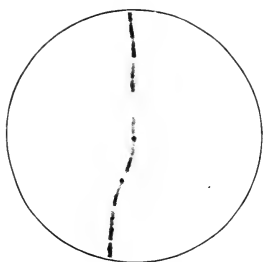

FIG. 18.—Cells of bacteria showing plasmolysis. The cell substance of three of the cells in the middle of the chain has shrunk until it appears as a round black mass. The cell wall shows as the lighter area.

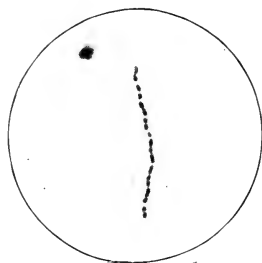

FIG. 19.—Vacuoles in the bacterial cell. The lighter areas are vacuoles.

**Nucleus.**—Douglas and Distaso<sup>1</sup> summarize the various opinions with regard to the nucleus in bacteria as follows:

1. Those who do not admit the presence of a nucleus or of anything equivalent to it (Fischer, Migula, Massart).

2. Those who consider that the entire bacterial cell is the equivalent of a nucleus and contains no cytoplasm (Ruzicka).

3. Those who admit the presence of nuclein but say that this is not morphologically differentiated from the protoplasm as a nucleus (Weigert).

<sup>1</sup> Centralblatt f. Bakteriologie, etc.. 1912, **63**, I abt. orig., 4; idem, 1912, **66**, I abt. orig., 323.



4. Those who consider the bacterial protoplasm to consist of a central endoplasm throughout which the nuclein is diffused and an external layer of ectoplasm next to the cell wall, (Bütschli, Zettnow).

5. Those who say that the bacterial cell contains a distinct nucleus, at least in most instances. These authors base their claims on staining with a Giemsa stain (Feinberg, Ziemann, Neuvel, Dobell, Douglass and Distaso).

That nucleoproteins are present in the bacterial cell in relatively large amounts is well established. Also, that there are other proteins and that the protoplasm is not all nuclein.

Some workers, as noted above, have been able to demonstrate collections of nuclein by staining, especially in very young cells. In older cells this material is in most instances diffused throughout the protoplasm and cannot be so differentiated.

The following statement probably represents the generally accepted view at the present time:

A nucleus *as such* is not present in bacterial cells except in a few large rare forms and in very young cells. *Nuclein*, the characteristic chemical substance in nuclei, which when aggregated forms the nucleus, is scattered throughout the cell contents and thus intimately mingled with the protoplasm, and cannot be differentiated by staining as in most cells.

The close association of nuclein and cytoplasm may explain the rapid rate of division of bacteria (Chapter VIII, page 72).

The chemical composition of the bacterial cell is discussed in Chapter VII.

In addition to the *essential* parts just described the bacterial cell may show some of the following *accidental* structures: *vacuoles*, *capsules*, *metachromatic granules*, *flagella*, *spores*.

**Vacuoles.**—*Vacuoles* appear as clear spaces in the cytoplasm when the organism is examined in the living condition or when stained very slightly (Fig. 19). During life these are filled with liquid or gaseous material which is sometimes waste, sometimes reserve food, sometimes digestive fluids.

Students are apt to confuse vacuoles with spores (page 32). Staining is the surest way to differentiate (Chapter XIX, page 206). If vacuoles have any special function, it is an unimportant one.

**Capsule.**—The *capsule* is a second covering outside the cell wall and probably developed from it (Fig. 20). It is usually gelatinous, so that bacteria which form capsules frequently stick together when growing in a fluid, so that the whole mass has a jelly-like consistency. The term *zoöglæa* was formerly applied to such masses, but is a poor term and misleading (*zoön* = an animal) and should be dropped. The masses of jelly-like material frequently found on decaying



FIG. 20.—Bacteria seen within capsules.

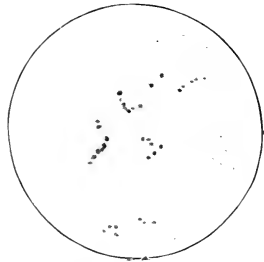

FIG. 21.—Metachromatic granules in bacteria. The dark round spots are the granules. The cells of the bacteria are scarcely visible.

wood, especially in rainy weather, are in some cases masses of capsule-forming bacteria, though a part of the jelly is a product of bacterial activity, a gum-like substance which lies among the capsulated organisms. When these masses dry out they become tough and leathery, but it is not to be presumed that capsules are of this consistency. On the contrary, they are soft and delicate, though they certainly serve as an additional protection to the organism, doubtless more by selective absorption than mechanically. Certain bacteria which cause disease form capsules in the blood of those animals which they kill and not in the blood of those in which they have no effect (*Bacillus anthracis* in guinea-

pig's blood and in rat's blood). The presence of capsules around an organism can be proved only by staining the capsule. Many bacteria when stained in albuminous fluids show a clear space around them which appears like a capsule. It is due to the contraction of the fluid away from the organism during drying.

**Metachromatic Granules.**—The term “*metachromatic*” is applied to granules which in stained preparations take a color different from the protoplasm as a whole (Fig. 21). They vary widely in chemical composition. Some of them are glycogen, some fat droplets. Others are so-called “granulose” closely related to starch but probably not true starch. Others are probably nuclein. Of many the chemical composition is unknown. They are called “Babes-Ernst corpuscles” in certain bacteria (typhoid bacillus). Since they frequently occur in the ends of cells the term “polar granules” is also applied. Their presence is of value in the recognition of but few bacteria (“Neisser granules” in diphtheria bacilli).

**Flagellum.**—A *flagellum* is a very minute thread-like process growing out from the cell wall, probably filled with a strand of cytoplasm. The vibrations of the flagella move the organism through the liquid medium. Bacteria which are thus capable of independent movement are spoken of as “motile bacteria.” The actual rate of movement is very slight, though in proportion to the size of the organism it may be considered rapid. Thus, Alfred Fischer determined that some organisms have a speed for short periods of about 40 cm. per hour. This is equivalent to a man moving more than 200 miles in the same time.

It is obvious that bacteria which can move about in a liquid have an advantage in obtaining food, since they do not need to wait for it to be brought to them. This advantage is probably slight.

An organism may have only one flagellum at the end. It is then said to be *monotrichic* (Fig. 22) ( $\mu\omicron\upsilon\sigma\tau$ , monos = alone, single;  $\tau\mu\epsilon\chi\omicron\sigma\tau$ , trichos = hair). This is most commonly at the front end, so that the bacterium is drawn through the liquid by its motion. Rarely it is at the rear end. Other bacteria

may possess a bundle of flagella at one end and are called *lophotrichic* (Fig. 23)  $\lambda\omicron\phi\omicron\tau$ , lophos = tuft). Sometimes at approaching division the flagella may be at both ends and are then *amphitrichic* (Fig. 24) ( $\alpha\mu\phi$ : amphi = both). It is

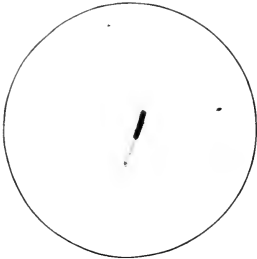

FIG. 22.—A bacterium showing a single flagellum at the end—monotrichic.



FIG. 23.—A bacterium showing a bundle of four flagella at the end—lophotrichic.

probable that this condition does not persist long but represents the development of flagella at one end of each of a pair resulting from division of an organism which has flagella at one end only. In many bacteria the flagella arise from all

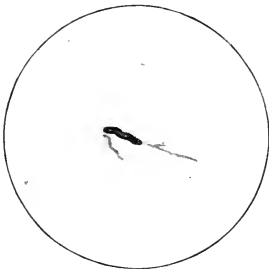

FIG. 24.—A bacterium showing flagella at each end—amphitrichic.

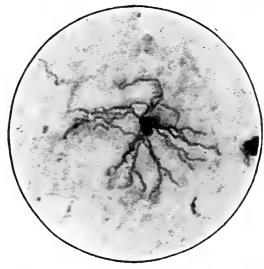

FIG. 25.—A bacterium showing flagella all around—peritrichic.

parts of the surface of the cell. Such bacteria are *peritrichic* (Figs. 25, 26) ( $\pi\epsilon\mu$ , peri = around). The position and even the number of the flagella are very constant for each kind and are of decided value in identification.

Flagella are too fine and delicate to be seen on the living organism or even on bacteria which have been colored by the ordinary stains. They are rendered visible only by certain methods which cause a precipitate on both bacteria and flagella, which are thereby made thick enough to be seen (Chapter XIX, page 207). The movement of liquid around a bacterium caused by vibrations of flagella can sometimes be observed with large forms and the use of "dark-field" illumination.

Flagella are very delicate and easily broken off from the cell body. Slight changes in the density or reaction of the medium frequently cause this breaking off, so that preparations made from actively motile bacteria frequently show

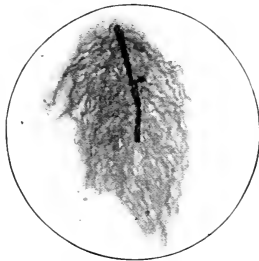

FIG. 26.—A bacillus with peritrichic flagella. (Student preparation.)

no flagella. For this reason and also on account of their fineness the demonstration of flagella is not easy, and it is not safe to say that a non-motile bacterium has no flagella except after very careful study.

The motion of bacteria is characteristic and a little practice in observing will enable the student to recognize it and distinguish between motility and "Brownian" or molecular motion. Dead and non-motile bacteria show the latter. In fact, any finely divided particles suspended in a liquid which is not too viscous and in which the particles are not soluble show Brownian motion or "pedesis." This latter is a dancing motion of the particle within a very small area and without change of place, while motile bacteria move

from place to place or even out of the field of the microscope with greater or less speed. There is a marked difference in the character of the motion of different kinds of bacteria. Some rotate around the long axis when moving, others vibrate from side to side.

Among the higher thread bacteria there are some which show motility without possessing flagella. Just how they move is little understood.

**Spores.**—Under certain conditions some bacterial cells undergo transformations which result in the formation of so-called *spores*. If the process is followed under the microscope the changes observed are approximately these: A very minute point appears in the protoplasm which seems to

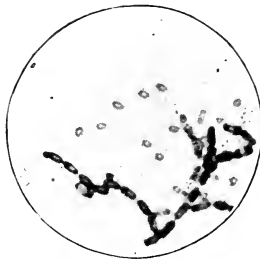

FIG. 27.—The smaller oval bodies in the middle of the field are free spores.

act somewhat like the centrosome of higher cells as a “center of attraction,” so that the protoplasm gradually collects around it. The spot disappears or is enclosed in the collected protoplasm. This has evidently become denser as it is more highly refractive than before. In time all or nearly all of the cytoplasm is collected. A new cell wall is developed around it which is thicker than the cell wall of the bacterium. This thickened cell wall is called the “spore capsule.” Gradually the remnants of the former cell contents and the old cell wall disappear or dissolve and the spore becomes “free” (Fig. 27).

If the spore is placed in favorable conditions the protoplasm absorbs water, swells, the capsule bursts at some point, a cell wall is formed and the bacterium grows to

normal size and divides, that is, it is an active growing cell again. This process is called "germination" of the spore. The point at which the spore capsule bursts to permit the

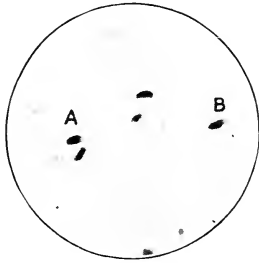

FIG. 28.—Spores showing polar germination. The lighter part of the two organisms just below *A* and *B* is the developing bacterium. In the original slide the spore was stained red and the developing bacterium a faint blue.

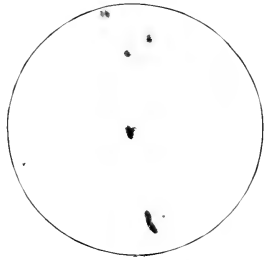

FIG. 29.—A spore showing equatorial germination. The spore in the center of the field shows a rod growing out of it laterally. In the original slide the spore was stained red and the developing bacterium blue.

new cell to emerge is characteristic for each kind of bacterium. It may be at the end when the germination is said

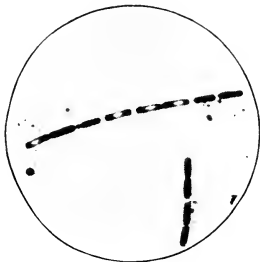

FIG. 30.—Spores in the middle of the rod without enlargement of the rod. The lighter areas in the rods are spores.



FIG. 31.—Spores in the middle of the rod with enlargement of the rod around them. The lighter areas in the rods are spores.

to be *polar* (Fig. 28). It may be from the middle of one side which gives *equatorial* germination (Fig. 29). Rarely it is diagonally from a point between the equator and the pole

which type may be styled *oblique* germination. In one or two instances the entire spore swells up, lengthens and becomes a rod without any special germination unless this type might be designated *bi-polar*.

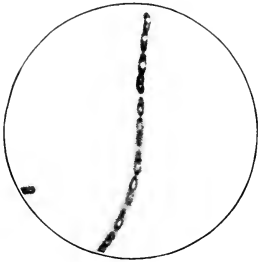

FIG. 32.—Spores in the end of the rod with no enlargement of the rod around them. The lighter areas in the rods are spores.

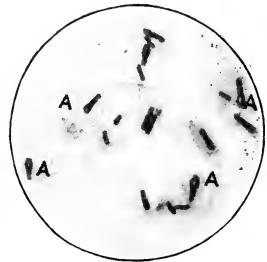

FIG. 33.—Spores in the end of the rod with enlargement of the rod, A, A, A, A.

Spores are most commonly oval or elliptical in shape, though sometimes spherical. A spore may be formed in the middle of the organism without (Fig. 30) or with (Fig. 31)

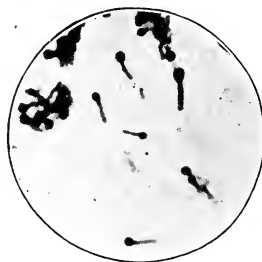

FIG. 34.—Drumstick spores at the end of the rod.

a change in size of the cell around it. If the diameter through the cell is increased, then the cell with the contained spore becomes spindle-shaped. Such a cell is termed a "*clostridium*." Sometimes the spore develops in the



end of the cell either without (Fig. 32) or with enlarging it (Fig. 33). In a few forms the spore is placed at the end of the rod and shows a marked enlargement. This is spoken of as the "*plectridium*," or more commonly the "drumstick spore" (Fig. 34). The position and shape of the spore are constant for each kind of bacteria. In one or two instances only two spores have been observed in a single organism.

The fact that the protoplasm is denser and the spore capsule thicker (the percentage of water in each is decidedly less than in the growing cell) gives the spore the property of much greater resistance to all destructive agencies than the active bacterium has. For example, all actively growing cells are destroyed by boiling in a very few minutes, while some spores require several hours' boiling. The same relation holds with regard to drying, the action of chemicals, light, etc. That the coagulation temperature of a protein varies inversely with the amount of water it contains is shown by the following table from Frost and McCampbell, *General Bacteriology*.

Egg albumen	plus 50 per cent	water	coagulates at	56°
"	"	" 25 per cent	"	" 74-80°
"	"	" 18 per cent	"	" 88-90°
"	"	" 6 per cent	"	" 145°
"	"	dry	"	" 160-170°

This resistance explains why it happens that food materials boiled and sealed in cans to prevent the entrance of organisms sometimes spoil. The spores have not been killed by the boiling. It explains also in part the persistence of some diseases like anthrax and black leg in pastures for years. From the above description it follows that the spore is to be considered as *a condensation of the bacterial protoplasm surrounded by an especially thick cell wall. Its function is the preservation of the organism under adverse conditions.* It corresponds most closely to the encystment of certain protozoa—the ameba for example. Possibly the spore represents a very rudimentary beginning of a reproductive function such as is gradually evolved in the higher thread bacteria, the fission yeasts, the yeasts, the molds, etc.

Its characteristics are so markedly different, however, that the function of preservation is certainly the main one.

*It is a mistaken idea that spores are formed under adverse conditions. Bacteria require just as exact conditions for spore formation as they do for growth and other functions (Chapters VI and VII). It is true that when the bacterium has changed to the spore stage the spore will resist adverse conditions much better than the bacterium in its growing stage.*

It is also a mistake to believe that most disease-producing organisms are spore formers. In Ohio and most of the Northern States *lock-jaw* and an occasional case of "*gas gangrene*" are almost the only diseases in man due to spore-forming bacteria. The author knows of only two cases of *anthrax* (caused by a spore-forming bacillus) in man in his own state. The organism which causes "*botulism*," a type of toxic food poisoning, is a spore former, but it does not grow in the body and cause disease.

*With the above exceptions not one of our common diseases is caused by a spore-forming organism and hence the organisms are very easily killed.*

## CHAPTER III.

### CELL FORMS.

THOUGH there is apparently a wide variation in the shapes of different bacterial cells, these may all be reduced to *three typical cell forms*. These are: first and simplest, the round or *spherical*, typified by a ball and called the *coccus* form, or *coccus*, plural cocci<sup>1</sup> (Fig. 35). The coccus may be large, that is, from  $1.5\ \mu$  to  $2\ \mu$  in diameter. The term *macro-coccus* is sometimes applied to these large cocci. If the *coccus* is less than  $1\ \mu$  in diameter, it is sometimes spoken of as a *micrococcus*; in fact, this term is very commonly applied to any coccus. When cocci are growing together, many of the cells do not appear as true spheres but are more or less distorted from pressure of their neighbors or from failure to grow to full size after recent division. Most cocci divide into hemispheres and then each half grows to full size. A few cocci elongate before division and then appear oval or elliptical.

The second cell form is that of a *cylinder* or rod typified by a section of a lead-pencil. The name *bacillus*, plural *bacilli*, is applied to this type (Fig. 36). The bacillus may be short (Fig. 37),  $1\ \mu$  or less in length, or long, up to  $40\ \mu$  in rare cases. Most bacilli are from  $2\ \mu$  to  $5\ \mu$  or  $6\ \mu$  long. The ends of the rod are usually rounded, occasionally square and very rarely pointed. It is evident that a very short rod with rounded ends approaches a coccus in form, and it is not always easy to differentiate in such cases. Most bacilli are straight, but some are slightly curved (Fig. 38).

The third cell form is the *spiral*, typified by a section of a cork-screw and named *spirillum*, plural *spirilla* (Fig. 39). A very short spiral consisting of only a portion of a turn is sometimes called *vibrio* (Fig. 40). Vibrios when seen under the microscope look like short curved rods. The distinc-

<sup>1</sup> The pronunciation of this word according to English standards is k6k-si.

tion between the two can be made only by examining the organism alive and moving in a liquid. The vibrio shows a characteristic spiral twisting motion. Very long, flexible

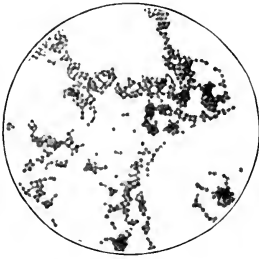

FIG. 35.—Cocci.

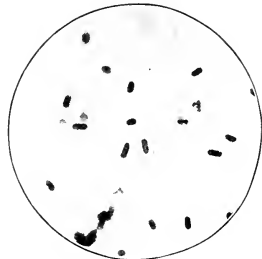

FIG. 36.—Bacilli.

spirals are usually named *spirochetes* (Fig. 41). The spirochetes are motile but flagella have not been shown to be present.

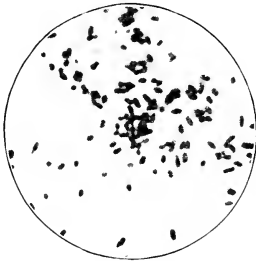

FIG. 37.—Short bacilli.



FIG. 38.—Curved bacilli. Only the one in the center of the field is in focus. The others curve out of focus.

Besides the three typical cell forms<sup>1</sup> bacteria frequently show very great irregularities in shape. They may be

<sup>1</sup> The three typical cell forms might be reduced to two the *sphere* and the *cylinder*, if one chose to consider the bacilli as *straight* or *curved cylinders* and the spirilla as *twisted cylinders*. The above division into three typical cell forms is practically universal.

pointed, bulged, club-shaped or even slightly branched. These peculiar and bizarre forms practically always occur when some of the necessary conditions for normal growth,

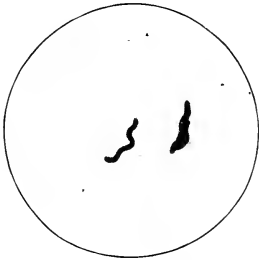

FIG. 39.—Spirilla.

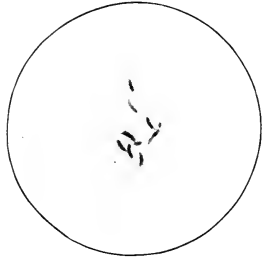

FIG. 40.—Vibrio forms of spirilla.  
Compare with Fig. 44.

discussed in Chapters VI and VII, are not fulfilled. They are best regarded as *involution* or *degeneration* forms for this reason (Fig. 42). In a very few cases it is not possible to

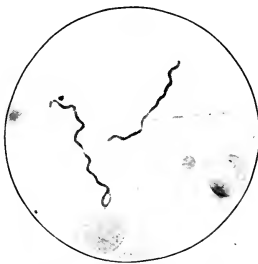

FIG. 41.—Spirochetes.

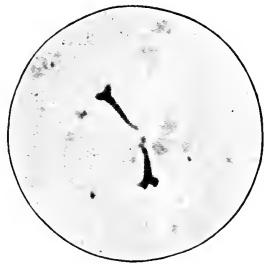

FIG. 42.—Involution forms. The organisms are tapering and branched at one end.

obtain the organism without these forms (the diphtheria group). It is probable that these cell forms are normal in such cases, or else conditions suitable for the normal growth have not been obtained.

CHAPTER IV.  
CELL GROUPINGS.

It has been stated that bacteria reproduce by transverse division, that is, division across the long axis. Following repeated divisions the new cells may or may not remain attached. In the latter case the bacteria occur as separate isolated individuals. In the former, arrangements characteristic of the particular organism almost invariably result. These arrangements are best described as *cell groupings* or *growth forms*.

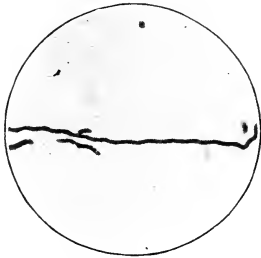

FIG. 43.—Streptospirillum grouping.

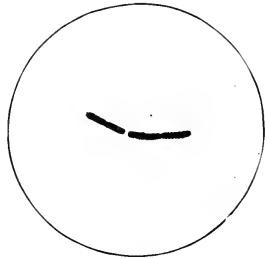

FIG. 44.—Diplobacillus grouping.

In the case of spiral forms it is obvious that there is only one possible grouping, that is, in chains of two or more individuals adherent end to end. A chain of two spirilla might be called a *diplospirillum* (διπλοσ, diplos — double); of three or more, a *streptospirillum* (στροπεπτοσ, streptos — necklace, chain) (Fig. 43). These terms are rarely used, since spirilla do not ordinarily remain attached. Likewise the bacillus can grow only in chains of two or more, and the terms *diplobacillus* (Fig. 44), bacilli in groups of two, and *streptobacillus* (Fig. 45), bacilli in chains are frequently used.

Still the terms *thread*, *filament* or *chain* are more common for *streptobacillus*.

Since the coccus is spherical, *transverse* division may occur in any direction, though in three planes only at right angles to each other. Division might occur in *one plane only*, as in spirilla and bacilli, or in *two planes only* or in all *three planes*.

As a matter of fact these three methods of division are found among the cocci, but only one method for each particular kind of coccus. As a result there may be a variety of cell groupings among the cocci. When division occurs in one plane the only possible groupings are the same as among the spirilla or bacilli. The cocci may occur in groups of two



FIG. 45.—Streptobacillus grouping.

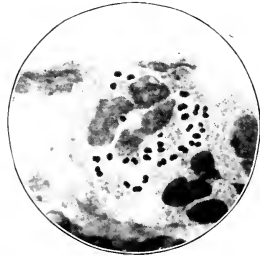

FIG. 46.— Typical diplococcus grouping. Note that the individual cocci are flattened on the apposing sides.

—*diplococcus* grouping (Fig. 46), or in chains—*streptococcus* groupings (Figs. 47 and 48). When the grouping is in *diplococci* the individual cocci most commonly appear as hemispheres with the plane surfaces apposed (Fig. 46). Sometimes they appear as spheres and occasionally are even somewhat elongated. The individuals in a streptococcus grouping are most commonly elongated, either in the same direction as the length of the chain or at right angles to it. The latter appearance is probably due to failure to enlarge completely after division. Streptococci frequently appear as chains of diplococci, that is, the pair resulting from the division of a single coccus remain a little closer to each

other than to neighboring cells, as a close inspection of Fig. 47 will show.

If division occurs in *two planes only*, there may result the above groupings and several others in addition. The four cocci which result from a single division may remain together, giving the *tetracoccus* or *tetrad* grouping. Very rarely all the cocci divide evenly and the result is a regular *rectangular flat mass* of cells, the total number of which is a multiple of four. The term *merismopedia* (from a genus of algae which grows the same way) is applied to such a grouping. If the cells within a group after a few divisions do not reproduce so rapidly (lack of food), as usually happens, the number of cells becomes uneven or at least not neces-

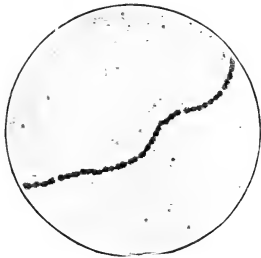

FIG. 47.—Long streptococcus grouping.

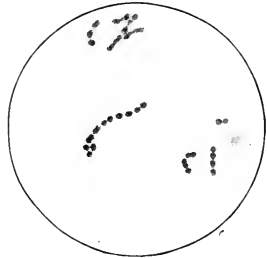

FIG. 48.—Short streptococcus grouping.

sarily a multiple of four and the resultant *flat mass* has an *irregular, uneven outline*. This grouping is termed *staphylococcus* (σταφυλόσ, staphylos = bunch of grapes) (Fig. 49). It is the most common grouping among the cocci.

When division occurs in all three planes, there is in addition to all the groupings possible to one- and two-plane division a third grouping in which the cells are in *solid packets, multiples of eight*. The name *sarcina* is applied to this growth form (Fig. 50). The individual cells in a sarcina packet never show the typical coccus form so long as they remain together, but are always flattened on two or more sides.

The above descriptions indicate how the method of divi-



sion may be determined. If in examining a preparation the *sarcina* grouping appears, that shows *three-plane division*. If there are no *sarcina* but *tetrads* or *staphylococci* (rarely *merismopedia*), then the division is in *two planes*. If none of the foregoing is observed but only *diplo-* or *streptococci*, these indicate *one-plane division* only. Cocci show their characteristic groupings only when grown in a liquid medium, and such should always be used before deciding on the plane of division.

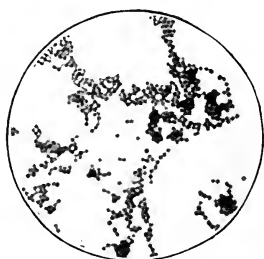

FIG. 49.—Staphylococcus grouping. The large flat masses are staphylococcus grouping. Diplococcus grouping, tetrads and short streptococci are also evident.

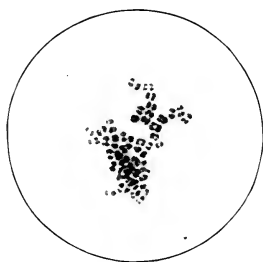

FIG. 50.—Sarcina grouping.

As the above description shows, these terms, which are properly adjectives describing the cell grouping, are quite generally used as nouns. Thus the terms a diplococcus, a tetrad, a streptococcus, etc., are common, meaning a bacterium of the cell form and cell grouping indicated.

## CELL FORM.

Coccus—round or spherical.

Bacillus—rod-shaped or cylindrical

Spirillum—spiral-shaped.

## CELL GROUPING.

{	diplococcus—in 2's.
	streptococcus—in chains.
	tetracoccus, tetrads—in 4's.
	staphylococcus—irregular flat masses.
	sarcina—regular, solid packets, multiples of 8.

{	diplobacillus—in 2's.
	streptobacillus—in chains.

{	diplospirillum—in 2's, little used.
	streptospirillum—in chains, little used

## CHAPTER V.

### CLASSIFICATION.

THE arrangement of living organisms in groups according to their resemblances and the adoption of *fixed names* is of the greatest advantage in their scientific study. For animal forms and for the higher plants this classification is gradually becoming standardized through the International Congress of Zoölogists and of Botanists respectively. Unfortunately, the naming of the bacteria has not as yet been taken up by the latter body, though announced as one of the subjects for the Congress of 1916 (postponed on account of the war). Hence there is at present no system which can be regarded as either fixed or official.

Since Müller's first classification of "animalcules" in 1786 numerous attempts have been made to solve the problem. Only those beginning with Ferdinand Cohn (1872-1875) are of any real value. As long as bacteria are regarded as plants, it appears that the logical method is to follow the well-established botanical principles in any system for naming them. Botanists depend on morphological features almost entirely in making their distinctions. The preceding chapters have shown that the minute plants which are discussed have very few such features. They are, to recapitulate, *cell wall, protoplasm, vacuoles, metachromatic granules, capsules, flagella, spores, cell forms* and *cell groupings*. Most bacteria show not more than three or four of these features, so that it is impossible by the aid of morphology alone to distinguish from each other the large number of different kinds which certainly exist. Physiological activities must be used as an aid to identification. Of the many systems that have been proposed the only one that will be considered in this work is:—

## THE CLASSIFICATION OF BERGEY'S MANUAL OF DETERMINATIVE BACTERIOLOGY.<sup>1</sup>

While there are many things in this Manual of Bergey's which need revision, it is nevertheless true that at present it is the best readily available source of descriptive bacteriology in this country. No attempt will be made to include all its details, but it is believed that an outline of the families and genera and a brief key will be helpful to the student. The summary is adapted from the *Journal of Bacteriology*, vol. xvi, No. 6, pp. 394-395—A Diagrammatic Summary of Various Bacterial Classifications. A Report of the Committee on Taxonomy (of the Society of American Bacteriologists). R. E. Buchanan, Chairman, R. S. Breed, L. F. Rettger.

### CLASS SCHIZOMYCETES.

Unicellular, non-chlorophyl-containing plants, reproducing by transverse division, some higher forms also by conidia.

#### KEY TO THE ORDERS.

1. Simple, undifferentiated forms without true branching. Sulphur and iron not stored as visible particles . . . . . I. *Eubacteriales*
2. Specialized or differentiated forms, some show true branching.
  - a Not protozoan like
    - b Mold like . . . . . II. *Actinomycetales*
    - bb Not mold like
      - c Sheathed . . . . . III. *Chlamydobacteriales*
      - cc Not sheathed
        - d Sulphur bacteria . . . . . IV. *Thiobacteriales*
        - dd Slime mold like . . . . . V. *Myxobacteriales*
    - aa Protozoan like, spiral . . . . . VI. *Spirochaetales*

#### KEY TO THE FAMILIES OF THE ORDER EUBACTERIALES.

1. Secure energy by oxidizing simple compounds of C-S-N-H, sometimes by oxidizing the elements S-H; some fix free N. . . . . I. *Nitrobacteriaceæ*
2. Do not secure energy as above.
  - a Cells spherical . . . . . II. *Coccaceæ*
  - aa Cells spiral . . . . . III. *Spirillaceæ*
  - aaa Cells cylindrical
    - b Spores not formed . . . . . IV. *Bacteriaceæ*
    - bb Spores formed . . . . . V. *Bacillaceæ*

<sup>1</sup> Williams & Wilkins Company, Baltimore, 2d Edition, 1925.

## KEY TO THE FAMILIES OF THE ORDER ACTINOMYCETALES.

1. Filamentous forms, frequently branched,  
saprophytes and some parasites . . . . . I. *Actinomycetaceæ*
2. Rod shaped, exceptionally filamentous  
or branched . . . . . II. *Mycobacteriaceæ*

## KEY TO THE GENERA OF MYCOBACTERIACEÆ.

1. Gram-positive
  - a Acid-fast . . . . . 1. *Mycobacterium* (*tubercle bacilli*)
  - aa Not acid-fast . . . . . 2. *Corynebacterium* (*diphtheria*)
2. Gram-negative
  - a Cells frequently fusiform . . . . . 3. *Fusiformis*
  - aa Cells not fusiform . . . . . 4. *Pfeifferella* (*glanders*)

## CLASS SCHIZOMYCETES

ORDER	FAMILY	SUBFAMILY	TRIBE	GENUS
I Eubacteriales.....	I Nitrobacteriaceæ.....		I Nitrobacteriæ	1 Hydrogenomonas
				2 Methanomonas
				3 Carboxydomonas
				4 Nitrosomonas
				5 Nitrobacter
				6 Nitrosococcus
				7 Acetobacter
				8 Thiobacillus
			II Azotobacteriæ....	9 Azotobacter
				10 Rhizobium
	II Coccaceæ.....		I Streptococceæ	1 Diplococcus
				2 Streptococcus
				3 Leuconostoc
			II Neisseriæ.....	4 Neisseria
				5 Gaffkya
			II Micrococceæ.....	6 Staphylococcus
	7 Micrococcus			
	8 Sarcina			
	9 Rhodococcus			
	III Spirillaceæ.....			1 Vibrio
				2 Spirillum
IV Bacteriaceæ.....		I Chromobacteriæ	1 Serratia	
			2 Flavobacterium	
			3 Chromobacterium	
			4 Pseudomonas	
		II Cellulomonadeæ..	5 Cellulomonas	
		III Achromobacteriæ	6 Achromobacter	
		IV Laetobacillæ....	7 Laetobacillus	
		V Erwiniæ.....	8 Erwinia	
			9 Phytomonas	
		VI Kurthiæ.....	10 Kurthia	
			VII Bacteriæ.....	11 Escherichia
12 Aerobacter				
13 Proteus				
14 Salmonella				
15 Eberthella				
16 Alcaligenes				
VIII Pasteurellæ....	17 Pasteurella			
IX Klebsiellæ.....	18 Klebsiella			
X Hemophilæ.....	19 Hemophilus			
	20 Dialister			
XI Bacteroidæ.....	21 Baeteroides			
	V Bacillaceæ.....			1 Bacillus
2 Clostridium				

## CLASSIFICATION FROM BERGEY—Continued

ORDER	FAMILY	SUBFAMILY	TRIBE	GENUS
II Actinomycetales . . . . .	I Actinomycetaceæ . . . . .			1 Actinobacillus
				2 Leptothrix
				3 Actinomyces
				4 Erysipelothrix
	II Mycobacteriaceæ . . . . .			1 Mycobacterium
				2 Corynebacterium
				3 Fusiformis
				4 Pfeifferella
III Chlamydo-bacteriales	I Chlamydo-bacteriaceæ . . . . .			1 Leptothrix
				2 Didymohelia
				3 Crenothrix
				4 Sphaerotilus
				5 Clonothrix
IV Thiobacteriales . . . . .	I Rhodobacteriaceæ . . . . .	I Chromatoideæ	I Thiocapsæ . . . . .	1 Thiocystis
				2 Thiosphæra
				3 Thiosphærium
				4 Thiocapsa
				5 Thiosarcina
			II Lamprocystæ . . . . .	6 Lamprocystis
			III Thiopediæ . . . . .	7 Thiopedia
				8 Thioderma
				9 Lampropedia
			IV Amœbobacteriæ . . . . .	10 Amœbobacter
				11 Thiodietyon
				12 Thiothece
				13 Thiopolycoecus
	V Chromatiæ . . . . .	14 Chromatium		
		15 Rhabdomonas		
		16 Thiospirillum		
		17 Rhodocapsa		
		18 Rhodothece		
		I Rhodobacterioidæ . . . . .	19 Rhodocystis	
			20 Rhodonostoc	
			21 Rhodorhagus	
			22 Rhodobacterium	
			23 Rhodobacillus	
			24 Rhodovibrio	
			25 Rhodospirillum	
	II Beggiatoaceæ . . . . .			1 Thiothrix
				2 Beggiatoa
				3 Thioploca
	III Achromatiaceæ . . . . .			1 Achromatium
				2 Thiophysa
				3 Thiospira
				4 Hillhusia
V Myxobacteriales . . . . .	I Myxobacteriaceæ . . . . .			1 Myxococcus
				2 Polyangium
				3 Chondromyces
VI Spirochætales . . . . .	I Spirochætaceæ . . . . .			1 Spirochæta
				2 Saprospira
				3 Cristispira
				4 Borrelia
				5 Treponema
				6 Leptospira

PART II.  
PHYSIOLOGY.

---

CHAPTER VI.  
GENERAL CONDITIONS FOR GROWTH.

**OCCURRENCE.**

BACTERIA are probably the most widely distributed of living organisms. They are found practically everywhere on the surface of the earth. Likewise in all surface waters, in streams, lakes and the sea. They occur in the air immediately above the surface, since they are carried up mechanically by air currents. They cannot fly of themselves. There is no reason to believe that any increase in numbers occurs to an appreciable extent in the air. The upper air, for example, on high mountains, is nearly free from them. So also is the air over mid-ocean and in high latitudes. As a rule, the greater the amount of dust in the air the more numerous are the bacteria. Hence they are found more abundantly in the air in cities and towns than in the open country. The soil is especially rich in numbers in the upper few feet, but they diminish rapidly below and almost disappear at depths of about six feet unless the soil is very porous and open, when they may be carried farther down. Hence the waters from deep wells and springs are usually devoid of these organisms. In the sea they occur at all levels and have been found in bottom ooze dredged from depths of several miles. It is perhaps needless to add that they are found on the bodies and in the alimentary tract of human beings and animals; on clothing, utensils; in dwellings, stables, outhouses, etc. From one-fourth to one-half of the

dry weight of the feces of animals and men is due to the bacteria present. The urine is practically free from them in health.<sup>1</sup>

While bacteria are thus found nearly everywhere, it is an entirely mistaken idea to suppose that all are injurious to man. As a matter of fact, those which are dangerous to man are relatively few and are for the most part found only in close association with man. Most bacteria are harmless and the vast majority are beneficial or even essential to man's existence on the earth. These facts must be constantly borne in mind, and it is hoped that the pages which follow will make them clear.

In order that any organism may thrive there are a number of general environmental conditions which must be fulfilled. These conditions vary more or less for each kind of organism. Bacteria are no exception to this general rule. These conditions may be conveniently considered under the general heads of *moisture; temperature; light; oxygen supply; osmotic pressure; action of electricity; of Roentgen and radium rays; pressure; mechanical vibration; and chemical environment*, including the *reaction of the medium, the effect of injurious chemicals*, and especially the *food requirements of bacteria*. For each of these conditions there is a *maximum*, meaning the greatest amount of the given condition which the organism can withstand, a *minimum*, or the least amount, and an *optimum*, or that amount which is most favorable for development. Further, there might be distinguished a maximum for *mere existence* and a lower maximum for *development*; also a minimum for *mere existence* and a higher minimum for *development*. These maxima, minima and optima for bacteria have been determined with exactness for only a very few of the general conditions and for comparatively few kinds.

The student cannot too early in his course grasp the idea that sufficient variation in *any one* of the environmental conditions will modify the characteristics of an organism.

<sup>1</sup> B. Renault has found bacteria in fossil remains of various epochs, Jurassic, Permian, Carboniferous, Devonian, Comp. Rend. Ac. Sci., 1894, **119**, 377-379; 1895, **120**, 162-164, 217-220; 1896, **122**, 1226; 1898, **126**, 1828-1831.



This applies to the morphological features described in Chapters II to IV and to all the physiological activities discussed in Chapters IX to XII. It is also fundamental in the discussion of disinfection and sterilization in Chapters XIII to XV, to the study of bacteria as treated in Part III and is no less applicable to Pathogenic Bacteriology to which Part IV forms an introduction.

Numerous articles appear even yet in bacteriological literature in which the sole conclusion is that the organism studied showed variations from the assumed normal under a given set of conditions.

The *fact* of variation with changes in environmental conditions should be *axiomatic* with the bacteriologist and no more work needs to be done to establish it.

On the other hand far too little has been done on a *quantitative* determination of the limits of any one of these conditions and on the range throughout which little variation is detectable. Many of these determinations for particular organisms have a most valuable practical as well as scientific application. This field is reserved for special bacteriology and does not come within the limits of this text-book which is concerned with having the student well grounded in fundamentals.

### MOISTURE.

The *maximum* moisture is absolutely pure water, and no organism can thrive in this alone owing to the factor of too low osmotic pressure and to the further factor of absence of food material. There are many bacteria, which thrive in water containing only traces of mineral salts and a large class whose natural habitat is surface water. These "water bacteria" are of great benefit in the purification of streams. They are as a class harmless to men and animals. Some of the disease-producing bacteria, like *Eberthella typhi* (of typhoid fever) and *Vibrio comma* (of Asiatic cholera), were undoubtedly originally water bacteria, and it is rather striking that in these diseases conditions are induced in the intestine (diarrheas) which simulate the original watery environment. The *minimum* moisture condition is abso-

lute dryness, and no organism can even exist, not to say develop, in such a condition since water is an essential constituent of living matter. Some bacteria, and especially most spores, may live when dried in the air or by artificial means for months and even years, while some are destroyed in a few hours or days when dried (typhoid, cholera, etc.). The optimum amount of moisture has not been determined with any great accuracy and certainly a rather wide range in percentage of water is permissible with many, though a liquid medium is usually most favorable for artificial growth. The "water bacteria" have been mentioned. In the soil a water content of 5 to 15 per cent seems to be most suitable for many of the organisms which aid in plant growth. In animals and man the organisms infecting the intestinal tract prefer a high percentage of moisture as a rule, especially those causing disease here. Those found on the surface of the body (pus cocci) need a less amount of water, while those invading the tissues (tuberculosis, black-leg, etc.) seem to be intermediate in this respect. In artificial culture media a water content of less than 30 per cent inhibits the growth of most bacteria.

As a general rule those bacteria which require the largest percentage of water are most susceptible to its loss and are most readily killed by drying. The typhoid and cholera organisms die in a few hours when dried, while pus cocci and tubercle bacilli live much longer.

### TEMPERATURE.

The temperature conditions for bacterial existence and growth have been determined more accurately than any of the other general conditions. The maximum for existence must be placed at or near 100°, since it is known that all bacteria including spores may be killed by boiling in time. Nevertheless, certain forms have been reported as thriving in hot springs where the water temperature was 93°. This is the highest known temperature for development. The minimum for existence lies at or near the absolute zero (−273°), since certain organisms have been subjected to the

temperature produced by the sudden evaporation of liquid hydrogen ( $-256^{\circ}$  to  $-265^{\circ}$ ) and have remained alive. Whether they could withstand such temperatures indefinitely is not known. The minimum for development is near the freezing-point of water, since reproduction by division has been observed in the water from melting sea-ice at a temperature of  $-1.5^{\circ}$ . Thus bacteria as a class have a range for existence of about  $373^{\circ}$  ( $-273^{\circ}$  to  $+100^{\circ}$ ) and for development of  $94.5^{\circ}$  ( $-1.5^{\circ}$  to  $+93^{\circ}$ ), certainly much wider ranges than any other group of organisms.<sup>1</sup>

The optimum temperature for development varies within rather wide limits for different organisms. In general it may be stated that the optimum temperature is approximately that of the natural habitat of the organism, though there are exceptions. The optimum of the "hot spring" bacteria just mentioned is apparently that of the springs ( $93^{\circ}$  in this case). Many soil organisms are known whose optimum is near  $70^{\circ}$  (a temperature rarely, if ever, attained in the soil) *when grown in air or oxygen*, but is very much lower when grown in the *absence of oxygen*. Many other soil organisms exhibit very little difference in rate or amount of growth when grown at temperatures which may vary as much as  $10^{\circ}$  or  $15^{\circ}$ , apparently an adaptation to their normal environment. The disease-producing organisms show much narrower limits for growth, especially those which are difficult to cultivate outside the body. For example, the bacterium of tuberculosis in man scarcely develops beyond the limits of  $2^{\circ}$  or  $3^{\circ}$  from the normal body temperature of man ( $37^{\circ}$ ), while the bacterium of tuberculosis in birds grows best at  $41^{\circ}$  to  $45^{\circ}$ , the normal for birds, and the bacterium of so-called tuberculosis of cold-blooded animals at  $14^{\circ}$  to  $18^{\circ}$ .

Those bacteria whose optimum temperature is above  $40^{\circ}$  are sometimes spoken of as the "*thermophil*" bacteria. The fixing of the "thermal death-point," that is the minimum

<sup>1</sup> With the possible exception of blue-green algæ which have been found with bacteria in the above-mentioned hot springs. Seeds of many plants have been subjected to as low temperatures as those above mentioned without apparent injury.

temperature at which the bacteria are killed within a given time limit, is a matter of great practical importance in many ways and numerous determinations of this have been made with a great many organisms and by different observers. The factors which enter into such determinations are so many and so varied that unless all the conditions of the experiment are given, together with the time of application, the mere statements are worthless. It may be stated that all *young, actively growing* (non-spore-containing) *disease-producing bacteria, when exposed in watery liquids and in small quantities are killed at a temperature of 60° within half an hour.* It is evident that this fact has very little practical application, since the conditions stated are rarely, if ever, fulfilled except in laboratory experiments. (See Sterilization and Pasteurization, Chapter XIII.)

### LIGHT.

Speaking generally, it can be said that light is destructive to bacteria. Many growing forms are killed in a few hours when properly exposed to direct sunlight and die out in several days in the diffuse daylight of a well-lighted room. Even spores are destroyed in a similar manner, though the exposure must be considerably longer. Certain bacteria which produce colors may grow in the light, since the pigments protect them. Some few kinds, like the sulphur bacteria, which contain a purplish-red pigment that serves them to break up  $H_2S$ , need light for their growth. Since disease-producing bacteria are all injuriously affected by light, the advantage of well-lighted habitations both for men and animals is obvious.

The destructive effect of light is due largely to the ultra-violet rays. Many investigators have studied this phenomenon. An excellent example of this type of work is that done by George N. Burger of the University of Cincinnati.<sup>1</sup>

Burger spread the organisms in a thin layer and exposed this to the rays from a quartz mercury arc. The following table gives some of his results and the photograph (Fig. 51) shows the effect on one of the organisms studied:

<sup>1</sup> Correlated Investigations in the Basic Sciences, Series IV, 1928, No. 2, pp. 46-54.

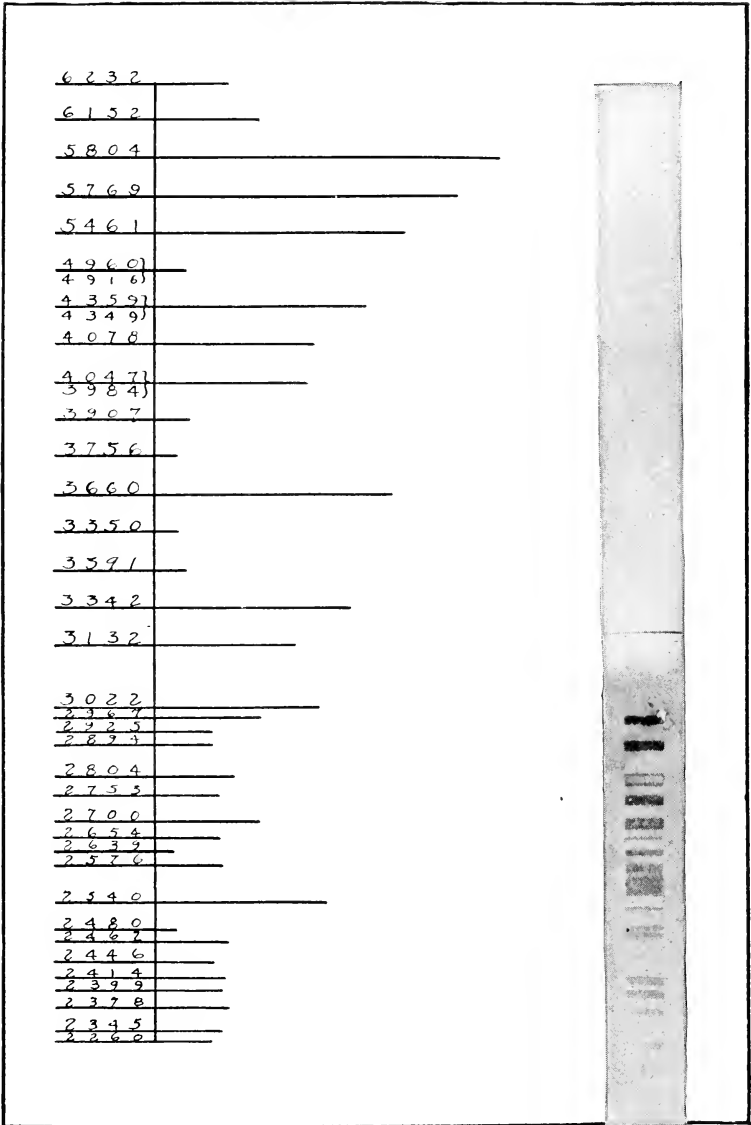

FIG. 51.—Staphylococcus albus.

	Time of exposure.	Longest killing wave-length.	Wave-lengths of max. killing.
Staphylococcus aureus . . .	1 hr.	3020 A°	{ 2800 A° 2650-2700 A° 2540 A°
Staphylococcus albus . . .	1 hr.	3020 A°	
Staphylococcus citreus . . .	1 hr.	"	Same in All
Salmonella schotmuelleri . . .	1 hr.	"	
Eberthella dysenteriae . . .	1 hr.	"	
Neisseria catarrhalis . . .	1 hr.	"	
Escherichia coli . . . . .	1 hr.	"	

### OXYGEN SUPPLY.

Oxygen is one of the constituents of protoplasm and is therefore necessary for all organisms. This does not mean that all organisms must obtain their supply from *free oxygen*, however, as animals and plants generally do. This fact is well illustrated by the differences among bacteria in this respect. Some bacteria *require free oxygen* for their growth and are therefore called *aërobic* bacteria or *aërobes* (sometimes *strict aërobes*, though the adjective is unnecessary). Others *cannot grow in the presence of free oxygen* and are therefore named *anaërobic bacteria* or *anaërobes* (strict is unnecessary). There are still other kinds which may grow either in the presence of free oxygen or in its absence, hence the term *facultative anaërobes* (usually) is applied to them.<sup>1</sup> The distinction between *facultative aërobe* and *facultative anaërobe* might be made. The former means those which grow best in the absence of free oxygen, though capable of growing in its presence, while the latter term means those which grow best in the presence of free oxygen but are capable of growing in its absence.

The amount of oxygen in the atmosphere in which an organism grows may be conveniently expressed in terms of the oxygen pressure, *i. e.*, in millimeters of mercury.

<sup>1</sup> It is popularly supposed that in canning fruit, vegetables, meats, etc., all the air must be removed, since the organisms which cause "spoiling" cannot grow in a vacuum. The existence of anaërobic and facultative anaërobic bacteria shows the fallacy of such beliefs.

It is evident that the maximum, minimum and optimum oxygen pressures for anaërobic bacteria are the same, namely, 0 mm. Hg. This is true only for natural conditions, since a number of anaërobic organisms have been gradually accustomed to increasing amounts of O, so that by this process of training they finally grew in ordinary air, that is, at an oxygen pressure of about 150 mm. Hg. (Normal air pressure is 760 mm. Hg. and oxygen makes up one-fifth of the air.) The minimum O pressure for facultative anaërobes is also 0 mm. Hg. Some experiments have been made to determine the limits for aërobes, but on a few organisms only, so that no general conclusions can be drawn from them. To illustrate: *Bacillus subtilis* (a common "hay bacillus") will grow at 10 mm. Hg. pressure but not at 5 mm. Hg. It will also grow in compressed oxygen at a pressure of three atmospheres (2280 mm. Hg.) but not at four atmospheres (3040 mm. Hg.), though it is not destroyed.

Parodko has determined the oxygen limits for five common organisms as follows:

	Maximum		Minimum	
	In atmospheres.	Mm. Hg.	Vol. per cent.	Mm. Hg.
<i>Pseudomonas fluorescens</i>	1.94 to 2.51	1474 to 1908	0.00016	= 0.0012
<i>Sarcina lutea</i>	2.51 to 3.18	1908 to 2417	0.00015	= 0.0011
<i>Proteus vulgaris</i>	3.63 to 4.35	2749 to 3306	0	0
<i>Escherichia coli</i>	4.09 to 4.84	3108 to 3478	0	0
<i>Serratia marcescens</i>	5.45 to 6.32	3152 to 4800	0	0

These few instances do not disclose any general principles which may be applied either for the growth or for the distinction of aërobes or facultative anaërobes.

It has been shown that compressed oxygen will kill some bacteria, but this method of destroying them has little or no practical value. Oxygen in the form of ozone, O<sub>3</sub>, is rapidly destructive to bacteria, and this fact is applied practically in the purification of water supplies for certain cities where the ozone is generated by electricity obtained cheaply from water power. The same is true of oxygen in the "nascent state," as illustrated by the use of hypochlorites for the same purpose.

Certain thermophil bacteria in the soil have an optimum

temperature for growth in the air much higher than is ever reached in their natural habitat, but they do grow at a moderate temperature under anaërobic conditions (page 53) When these organisms are grown with aërobes or facultative anaërobes they thrive at ordinary temperatures. These latter organisms use up the oxygen and keep the tension low. This explains how thermophil organisms may grow in the soil.

These organisms illustrate the fact that relationships to one environmental condition are greatly modified by some other environmental condition. In this case growth at high temperatures is dependent upon abundant oxygen supply while growth at low temperatures can occur only with diminished oxygen supply. Such interrelations of environmental conditions are the rule and not the exception.

### OSMOTIC PRESSURE.

Like all living cells bacteria are very susceptible to changes in the density of the surrounding medium. If placed in a medium less concentrated than their own protoplasm water is absorbed and they tend to "swell up;" while if placed in a denser medium water is given off and the cytoplasm shrinks (plasmoptysis or plasmolysis). Should these differences be marked or the transition be sudden, the cell walls may even burst and the organisms be destroyed. If the differences are not too great or if the transition is made gradually, the organisms may not be destroyed, but will either cease to grow and slowly die out, or will show very much retarded growth, or will produce abnormal cell forms. This is illustrated in the laboratory in attempting to grow bacteria on food material which has dried out.

A practical application of osmotic effects is in the use of a high percentage of sugar in preserving fruits, etc., and in the salting of meats. Neither the cane-sugar nor the common salt themselves injure the bacteria chemically, but by the high concentration prevent their development. In drying material in order to preserve it there are two factors involved: first, the loss of water necessary for growth and second, the increased osmotic pressure.



In a medium of greater density diffusion of water is outward from the cell and this will continue until an equilibrium is established between cell contents and medium. Food for the organism *must be in solution and enter the cell by diffusion*. Therefore, growth ceases in a medium too dense, since water to carry food in solution does not enter the cell.

### ELECTRICITY.

Careful experimenters have shown that the electric current, either direct or alternating, has no direct destructive effect, on bacteria. In a liquid medium the organisms may be attracted to or repelled from one or the other pole or may arrange themselves in definite ways between the poles (galvanotaxis), but are not injured. However, electricity through the *secondary* effects produced may be used to destroy bacteria. If the passage of the electric current *increases the temperature* of the medium sufficiently the bacteria will be killed, or if *injurious chemical substances* are formed (ozone, chlorine, acids, bases, etc.), the same result will follow (see Ozone, pages 57 and 143). (Thunderstorms, see page 73).

### RADIATIONS.

Roentgen or  $x$ -rays and radium emanations when properly applied to bacteria will destroy them. The practical use of these agents for the direct destruction of bacteria in diseases of man or animals is restricted to those cases where they may be applied directly to the diseased area, since they are just as injurious to the animal cell as they are to the bacteria, and even more so. Their skilful use as *stimuli to the body cells* to enable them to resist and overcome bacteria and other injurious organisms or cell growths is an entirely different function and will not be considered here.

### PRESSURE.

Hydrostatic pressure up to about 10,000 pounds per square inch is without appreciable effect on bacteria, as has

been shown by several experimenters and also by finding living bacteria in the ooze dredged from the bottom of the ocean at depths of several miles.

Pressures from 10,000 to 100,000 pounds show variable effects. Some bacteria are readily killed and others, even non-spore formers, are only slightly affected. The time factor is important in this connection. The presence of acids, even CO<sub>2</sub>, or organic acids, results in the destruction of most non-spore formers.

### MECHANICAL VIBRATION.

Vibrations transmitted to bacteria in a liquid may be injurious to them under certain circumstances. Some of the larger forms, like *Bacillus subtilis*, may be completely destroyed by shaking in a rapidly moving shaking machine in a few hours. Bacteria in liquids placed on portions of machinery where only a slight trembling is felt have been found to be killed after several days. Reinke has shown that the passing of strong sound waves through bacterial growths markedly inhibits their development.

### HIGH FREQUENCY VIBRATIONS.

The injurious effects of high frequency sound waves, up to millions per second, produced by quartz crystals under the influence of electric forces have been studied on mice and other small animals and their heating effect on man has been noted. Also some experiments on high frequency electric currents, 66,000,000 to 68,000,000 per second, on certain tumor (sarcoma) cells in mice have been reported.<sup>1</sup> The author has been expecting to read of similar work on bacteria. If it has appeared it has escaped his notice. One would anticipate markedly injurious action from either of the above "high frequency vibrations." Whether they would have practical use against bacteria requires further study.

<sup>1</sup> Schereschewsky, J. W. and Andervont, H. B.: "The Action of Currents of Very High Frequency upon Tissue Cells," Public Health Reports, April 20, 1928, pp. 927-945.

## CHAPTER VII.

### CHEMICAL ENVIRONMENT.

#### REACTION OF MEDIUM.<sup>1</sup>

MOST bacteria are very susceptible to changes in the degree of acidity or alkalinity of the medium in which they grow. Some kinds prefer a slightly acid reaction, some a slightly alkaline and some a neutral. The organism which is the commonest cause of the souring of milk thrives so well in the acid medium it produces that it crowds out practically all other kinds, though its own growth is eventually stopped by too much acid. Acid soils are usually low in numbers of bacteria and as a consequence produce poor crops. The disease-producing bacteria as a class grow best in a medium which is near the neutral point.

Accurate determination of limits have been made on but few organisms. The reaction is a most important factor in growing bacteria on artificial media (see Making of Media, Chapter XVI).

#### INJURIOUS CHEMICAL SUBSTANCES.

(SEE DISINFECTION AND DISINFECTANTS, Chapter XIII.)

#### CHEMICAL COMPOSITION.

The chemical composition is subject to wide variation chiefly for two reasons: First, the cell wall in most instances seems to exert only a slight selective action in the absorption of mineral salts, so that their concentration within the cell is very nearly that of the surrounding medium. Second, the chief organic constituents vary remarkably with the

<sup>1</sup> For a discussion of reaction see page 161.

kind and amount of food material available—a rich protein pabulum increases the protein, a plentiful supply of carbohydrates or of fat results in the storing of more fat especially, and *vice versa*. These facts must be borne in mind in considering the chemistry of bacteria.

Of the chemical elements known, only the following seem to be essential in the structure of bacteria: (1) *Carbon*; (2) *hydrogen*; (3) *oxygen*; (4) *nitrogen*; (5) *sulphur*; (6) *phosphorus*; (7) *chlorine*; (8) *potassium*; (9) *calcium*; (10) *magnesium*; (11) *iron*; (12) *manganese*. Other elements, as sodium, iodine, silicon, aluminum, lithium, copper, etc., have been reported by different analysts, but none of them can be regarded as essential, except possibly in isolated instances.

These elements exist in the bacterial cell in a great variety of combinations, of which the most abundant is *water*. The amount of water varies in different species from 75 to 90 per cent of the total weight in growing cells, and is less in spores. The amount of *ash* has been shown by different observers to vary from less than 2 per cent to as much as 30 per cent of the *dry weight*. The following table compiled from various sources will give an idea of the relative abundance of the different elements in the ash:

S	as SO <sub>3</sub>	.	7.64	per cent	(much more in sulphur bacteria)
P	as P <sub>2</sub> O <sub>5</sub>	.	18.14	"	to 73.94 per cent.
Cl	.	.	2.29	"	
K	as K <sub>2</sub> O	.	11.1	"	to 25.29 "
Ca	as CaO	.	12.64	"	to 14.0 "
Mg	as MgO	.	0.7	"	to 11.55 "
Fe	as Fe <sub>2</sub> O <sub>3</sub>	.	1.0	"	to 8.15 " (iron bacteria)
Mn	.	.	traces		

As to the form in which the last six elements in the table exist in the cell, little is known. The sulphur and phosphorus are essential constituents of various proteins. The high percentage of phosphorus points to nuclein compounds as its probable source.

The carbon and nitrogen, together with most of the hydrogen and oxygen not united as water, make up the great variety of organic compounds which compose the main substances in the bacterial cell.

It has already been stated that the essential structures in the bacterial cell are cell wall and protoplasm, including the nuclein. These differ markedly in chemical composition. It is well known that the cell walls of green plants consist largely of cellulose and closely related substances.<sup>1</sup> *True cellulose* has been recognized in but very few bacteria. (*Sarcina ventriculi*, Migula; *Mycobacterium tuberculosis*, Hammerschlag, Dreyfuss, Nishimura; *Bacillus subtilis*, Dreyfuss; *Acetobacter xylinum*, Brown; *Acetobacter acidi oxalici*, Banning; and a few others.) It is certainly not an important constituent of the cell wall in many. On the other hand *hemicellulose* and *gum-like* substances have been identified in numerous organisms of this class as important constituents of the cell wall and of the capsule which is probably an outgrowth from the latter. Practically always associated with these substances are compounds containing nitrogen. One of these has been certainly identified as *chitin* or a closely similar substance. Chitin is the nitrogenous substance which enters largely into the composition of the hard parts of insects, spiders and crustaceans. It is an interesting fact to find this substance characteristic of these animals in bacteria as well as other fungi.

Though it is extremely difficult to separate the cell wall of bacteria from the cell contents, in the light of our present knowledge it can be stated that the cell walls are composed of a carbohydrate body closely related to cellulose, though not true cellulose, probably in close combination with chitin.

Of the organic constituents of the cell contents the most abundant are various proteins which ordinarily make up about one-half of the dry weight of the entire cell. The "Mycoproteid" of Nencki, 1879, and other earlier workers is deserving of little more than historical interest, since these substances were certainly very impure and probably consisted of mixtures of several "proteins" in the more recent sense.

<sup>1</sup> "By cellulose is understood a carbohydrate of the general formula  $C_6H_{10}O_5$  not soluble in water, alcohol, ether or dilute acids but soluble in an ammoniacal solution of copper oxide. It gives with iodine and sulphuric acid a blue color and with iodine zinc chloride a violet and yields dextrose on hydrolysis."—H. Fischer.

From later studies it seems probable that substances resembling the albumin of higher forms do not occur in bacteria, at least in appreciable quantities. Globulin has been reported by Hellmich in an undetermined bacterium, but is certainly not commonly found. The larger portion of the protein is of a comparatively simple type, in fact, consists of protamines most of which are in combination with nucleic acid as nucleoprotamines. Practically all recent workers find a high percentage of nuclein, both actually isolated and as indicated by the amounts of purin bases—xanthin, guanin, adenin—obtained, as well as by the abundance of phosphorus in the ash, already mentioned. Some of these nucleins have been shown to have poisonous properties.

Closely related to but not identical with the proteins are the enzymes and toxins which are formed in the cell and exist there as endo-enzymes or endo-toxins respectively. These substances will be discussed later under the heading "Physiological Activities of Bacteria" (Chapter XII).

Carbohydrates are not commonly present in the cell contents, though glycogen has been observed in a few and a substance staining blue with iodine in one or two others. This latter substance was at first considered to be starch "granulose," but is probably more closely related to glycogen.

Fats seem to be very generally present. The commoner fats—tri-olein, tri-palmitin, tri-stearin—have been found by many analysts. The "acid-fast bacteria" are particularly rich in fatty substances, especially the higher wax-like fats. Lecithins (phosphorized fats) and cholesterins (not fats but alcohols) have been repeatedly observed and probably occur in all bacteria as products of katabolism.

Organic acids and esters occur as cell constituents, but will be discussed in connection with their more characteristic occurrences as products of bacterial activity, as will also pigments which may likewise be intracellular in some instances.

The following analysis of tubercle bacilli, from de Schweinitz and Dorset, while not intended as typical for all bacteria, still illustrates the high percentage of protein

compounds which undoubtedly occurs in most, as well as showing the large amounts of fatty substance in a typical "acid-fast" organism:

In the dried organisms	}	8.5 per cent	tuberculinic acid	} 55.8 per cent protein.
		24.5	" nucleoprotamin	
		23.0	" neucleoprotein	
		8.3	" proteinoid	
		26.5	" fat and wax	
		9.2	" ash	

From the foregoing discussion of chemical composition a number of characteristics are apparent. No one of these is restricted to bacteria, but taken together they differentiate the bacteria rather sharply from other organisms except fungous plants. Chemical composition is one of the strongest arguments for classifying the bacteria with plants. These characteristics are:

1. The variability of the composition of any given organism with the composition of the surrounding medium.

2. The large percentage of *phosphorus*.

3. The presence of some *nitrogen compound* in the cell wall. (Found in yeasts and molds also.)

4. The presence of *glycogen* as the carbohydrate stored in the cell and *not starch*. All fungous plants store glycogen in this way.

5. The relatively large percentage of *protein*.

6. The protein is not like the albumins and globulins of higher forms.

7. The protein is very largely of the simpler type—*protamines*. Protamines are found especially abundant in the eggs and sperm of many fish.

8. The protamines are to a great extent combined with *nuclein*.

9. The large percentage of *nuclein*. This is also characteristic of eggs, sperm, embryonic tissue cells, many types of cancer cells, in fact in cells characterized by a *rapid rate* of multiplication and a rapid metabolism. It may account for the rate of increase of bacteria and their capacity to bring about great chemical changes in a short time discussed at the close of the next chapter.

## CHAPTER VIII.

### CHEMICAL ENVIRONMENT (CONTINUED).

#### GENERAL FOOD RELATIONSHIPS. METABOLISM.

THE foregoing brief review of the chemical composition of the bacterial cell illustrates the variety of compounds which necessarily occurs, but affords no definite clue as to the source of the elements which enter into these compounds. These elements come from the material which the organism uses as *food*. *Under this term are included elements or compounds which serve as building material, either for new cell substance or to repair waste, or as sources of energy.*

An organism which is capable of making use of an element in the free state is said to be *prototrophic* for that particular element. Thus aërobes and facultative anaërobes are prototrophic for O. The "root-tubercle bacteria" of leguminous and other plants and certain free living soil organisms are prototrophic for N.<sup>1</sup>

On the other hand, if the element must be secured from compounds, then the organism is *metatrophic* in respect to the element in question. Should the compound be inorganic the term *autotrophic* is applied to the organism and *heterotrophic* if the compound is organic. It is very probable that anaërobes, exclusive of a few nitrogen absorbers, are metatrophic for all the elements they utilize. With the exception of the anaërobes it seems that all bacteria are *mixotrophic*, that is, prototrophic for one or two elements and auto- or heterotrophic for the others.<sup>2</sup>

<sup>1</sup> The sulphur bacteria are partially prototrophic for S; probably the iron bacteria also for Fe. Some few soil bacteria have been shown to be capable of utilizing free H, and it seems certain that the bacteria associated with the spontaneous heating of coal may oxidize free C. So far as known no elements other than these six are directly available to bacteria.

<sup>2</sup> Only a few kinds of bacteria so far as known are proto-autotrophic. The nitrous and nitric organisms of Winogradsky, which are so essential in the soil and which might have been the first of all organisms so far as their food is concerned, and some of the sulphur bacteria are examples.



Those bacteria whose food consists of dead material, either organic or inorganic, are spoken of as *saprophytes*, while those whose natural habitat, without reference to their food, is in or on other living organisms are called *parasites*. *These two terms are frequently used as though they were opposites. This cannot be true, since they do not refer to the same thing.* Saprophyte, as just stated, has reference to *food*, while parasite refers to *place of abode*. Usually the place of abode determines the character of the food, but there is no necessary connection. Many parasites are saprophytes, hence the terms are not mutually exclusive. In fact, strictly speaking, all parasitic bacteria are saprophytes, since the food must enter the cell in solution and living matter is not soluble. Hence the actual food is dead material.

The *host* is the organism in or on which the parasite lives. Parasites may be of several kinds. Those which neither do injury nor are of benefit to the host are called *non-pathogenic* parasites or *commensals*; many of the bacteria in the intestines of man and other animals are of this class. Those which do injury to the host are called *pathogenic* or disease-producing, as the organisms causing the transmissible diseases of animals and plants.<sup>1</sup> Finally, we have those parasites which are of benefit to and receive benefit from the host. These are called *symbionts* or *symbiotic parasites* and the mutual relationship *symbiosis*. Certain of the intestinal bacteria in man, and especially in herbivorous animals, are undoubted *symbionts*, as are also the "root-tubercle bacteria" already mentioned.

The term *strict* parasite refers to those parasites which *under natural conditions* do not reproduce apart from the host. *Facultative* parasites may reproduce under natural conditions either in or on the host or apart from it. There is no known parasitic bacterium which has not been grown *artificially* apart from its host.

Bacteria bring about a great many changes on their food

<sup>1</sup> The term *pathogenic* is also applied to certain non-parasitic saprophytic bacteria whose products cause disease conditions, as one of the organisms causing a type of food poisoning in man (*Clostridium botulinum*), which also probably causes "forage poisoning" in domestic animals.

material which are usually spoken of as "physiological activities."<sup>1</sup> Some of these changes certainly occur within the cell as anabolic and katabolic processes. Very little is known about such changes. However, many physiological activities occur without the cell and can be more accurately determined. Some of these changes are to be ascribed to the utilization of certain of the elements and compounds in these materials as tissue builders, some as energy-yielding reactions and still others as giving rise to substances that are of direct benefit to the organism concerned in its competition with other organisms.

Though all of the twelve elements already mentioned are essential for the growth of every bacterium, two of them are of especial importance for the reason that most of the "physiological activities" to be described in the next chapters are centered around their acquisition and utilization. These elements are *carbon* and *nitrogen*. Some few of the special activities of certain groups have to do with one or the other of the remaining nine, as will be shown later. But generally speaking *when a bacterium under natural conditions secures an adequate supply of carbon and nitrogen, the other elements are readily available in sufficient amount*. The reason is that these elements are most frequently secured from organic compounds derived from the bodies, living or dead, of other organisms, plant or animal. These bodies also contain the other elements.

**Carbon Metabolism.**—Carbon is necessary not only because it is an essential constituent of protoplasm but because its oxidation is the chief source of the energy necessary for the internal life of the cell, though nitrogen and sulphur replace it in this function with a few forms. This latter use of carbon (for oxidation to furnish energy) constitutes what may be called its *respiratory function*. Bacteria like other organisms in their respiration utilize oxygen and give off carbon dioxide. The amount of the latter given off from the cell in this way is very small as compared with that which is frequently produced as an accompaniment of other reactions (see

<sup>1</sup> The student must not forget that "physiological activities" include also motion, growth, reproduction and internal metabolism.

Fermentation, next chapter). But there is no doubt of its formation and it has been determined by a few investigators. On account of this use of carbon, bacteria require relatively large amounts of this element. One group of bacteria concerned in the spontaneous heating of coal seems to be able to use free carbon from this material both for building purposes and to furnish energy. Another group is said to be able to oxidize marsh gas,  $\text{CH}_4$ , and derive energy from this oxidation and also use this gas as a source of carbon for building purposes. The nitrite, nitrate and sulphur bacteria mentioned later utilize carbon dioxide and carbonates as their carbon supply for building purposes only. Their energy is derived from the oxidation of nitrogen or sulphur compounds respectively. Thus these latter elements may be called the "respiratory elements" of these classes of bacteria. One kind of bacterium has been described which uses carbon monoxide, oxidizing a part to furnish energy and reserving a part as a source of carbon for building. With the exception of these few kinds of bacteria which are able to use carbon in the relatively simple *inorganic* forms just mentioned, bacteria are dependent on carbon from *organic compounds* both for respiratory and for building purposes and cannot use  $\text{CO}_2$  for the latter purpose as green plants do.

**Oxygen Metabolism.**—The oxygen requirement is high partly on account of its use in respiration. The energy which bacteria require in their life processes is, so far as known, all derived from oxidation. Oxygen is also largely used for building purposes, since it is one of the elements necessary in the formation of most of the compounds present in the bacterial cell, as has been pointed out in Chapter VII. Aërobic bacteria are compelled to obtain part of their oxygen from the surrounding atmosphere, though they do obtain part from combination. The free oxygen is probably used for oxidative purposes to furnish energy. Anaërobic bacteria are dependent on so-called "molecular respiration" for their energy. That is, through a shifting or rearrangement of the atoms in the compounds used as food, some of the elements are oxidized by the oxygen present. One evidence of this is

the production of  $\text{CO}_2$  by anaërobes as well as by aërobes. Enzymes are probably responsible for this action. A carbohydrate is usually though not always essential for the growth of anaërobes and serves them as the best source of energy.

**Nitrogen Metabolism.**—Nitrogen is the characteristic element of living material. Protoplasm is a colloidal chemical system in unstable equilibrium and nitrogen is responsible for this instability. No other of the commoner elements is brought into combination with such difficulty, nor is so readily liberated when combined (all commercial explosives are nitrogen compounds). Bacteria, like other forms of protoplasm, require nitrogen. More marked peculiarities are shown by bacteria with reference to the sources from which they derive their nitrogen than for carbon. Some can even combine the free nitrogen of the air and furnish the only natural means of any importance for this reaction. Some few forms (the nitrite and nitrate formers, Chapter XI) obtain their energy from the oxidation of inorganic nitrogen compounds, ammonia and nitrites respectively, and not from carbon. These latter bacteria use carbon from carbon dioxide and carbonates as building material and not as a source of energy. A great many bacteria can secure their nitrogen from nitrates but some are restricted to organic nitrogen. Many bacteria obtain their carbon from the same organic compounds from which their nitrogen is derived.

**Sulphur Metabolism.**—Sulphur serves mainly as a constituent of protein compounds in the protoplasmic structure. In some of the *sulphur* bacteria it is a source of energy, since either free sulphur or  $\text{H}_2\text{S}$  or various thiosulphates are oxidized by them. Some of these bacteria can obtain their carbon from  $\text{CO}_2$  or carbonates, for structural purposes, not for oxidation, and their nitrogen from nitrates or ammonium salts.

Whether the *iron* bacteria, belonging to the genus *Crenothrix* of the higher, thread bacteria, use this element or its compounds as sources of energy is still a disputed question. The evidence is largely in favor of this view.

Free hydrogen has been shown to be oxidized by some forms which obtain their energy in this way.

Whether there is a special class of *phosphorus* bacteria remains to be discovered. That phosphorus is oxidized during the activity of many bacteria is undoubted, but whether this represents a source of energy or is the accidental by-product of other activities is undetermined.

Practically nothing is known about the metabolism of the other elements as such.

From the preceding brief review of the relation of certain bacteria to some of the elements in the free state, and from the further fact that there is scarcely a known natural organic compound which cannot be utilized by some kind of bacterium, it is evident that this class of organisms has a far wider range of adaptability than any other class, and this adaptability helps to explain their seemingly universal distribution.

As to the metabolism *within the cell*, no more is known than is the case with other cells, nor even as much. The materials used for growth and as sources of energy are taken into the cell, built up into various compounds, some of which have been enumerated, and in part broken down again. Carbon dioxide and water are formed in the latter process. What other katabolic products occur it is not easy to determine. Certainly some of the substances mentioned in the next chapters are such products, but it is not always possible to separate those formed *inside* the cell from those formed *outside*. Perhaps most of the latter should be considered true metabolic products. It would seem that on account of the simplicity of structure of the bacterial cell and of the compounds which they may use as food they would serve as excellent objects for the study of the fundamental problems of cell metabolism. Their minuteness and the nearly impossible task of separating them completely from the medium in or on which they are grown makes the solution of these problems one of great difficulty.

When all of the environmental conditions necessary for the best development of a given bacterium are fulfilled, it will then develop to the limit of its capacity. This development is characterized essentially by its reproduction, which occurs by transverse division. The rate of this division

varies much with the kind even under good conditions. The most rapid rate so far observed is a division in eighteen minutes. A great many reproduce every half-hour, and this may be taken as a good average rate. If such division could proceed without interruption, a little calculation will show that in about sixty-five hours a mass as large as the earth would be produced.

Starting with 1 coccus, 1 $\mu$ in diameter,		
	its volume = 0.0000000000005 cc.	
$\frac{1}{2}$ hour =	2	
1 hour =	4	
2 hours =	16	
4 hours =	256	
5 hours =	1024 = $10^3 +$	
15 hours =	1,000,000,000 = $10^9 =$	0.0005 cc.
35 hours =	$10^{21} +$	= 500.0 cu.m.
About 65 hours =	$2 \times 10^{42} +$	= $5 \times 10^{20}$ cu.m. = a mass as large as the earth.

Such a rate of increase evidently cannot be kept up long on account of many limiting factors, chief of which is the food supply.

The foregoing calculation is based on the assumption that the organism divides in one plane only. If it divides in two or three planes the rate is much faster, as is shown by the following formulæ which indicate the theoretical rate of division:

$$\begin{aligned}
 S &= \text{number of bacteria after a given number of divisions.} \\
 a &= \text{number at the beginning and } n = \text{number of divisions.} \\
 &\quad 1 \text{ plane division } S = 2^n a \\
 &\quad 2 \quad \quad \quad \quad S = 2^{2n} a \\
 &\quad 3 \quad \quad \quad \quad S = 2^{3n} a
 \end{aligned}$$

With two-plane or three-plane division, assuming that each organism attains full size, as was assumed in the first calculation, the "mass as large as the earth" would be attained in about thirty-two and twenty-two hours respectively.

This extraordinary rate of increase explains in large measure why bacteria are able to bring about such great chemical changes in so short a time as is seen in the rapid

“spoiling” of food material, especially liquids. The reactions brought about by bacteria on substances which are soluble and diffusible are essentially “surface reactions.” The material diffuses into the cell over its entire surface with little hindrance. The bacteria are usually distributed throughout the medium, so that there is very intimate contact in all parts of the mass which favors rapid chemical action. The following calculation illustrates this:

The volume of a coccus  $1 \mu$  in diameter is  $0.5236 \times 10^{-12}$  cc.  
 The surface of a coccus  $1 \mu$  in diameter is  $\pi \times 10^{-8}$  sq. cm.

It is not uncommon to find in milk on the point of souring 1,000,000,000 bacteria per cc.

Assuming these to be cocci of  $1 \mu$  diameter the volume of these bacteria in a liter is only 0.05 cc, or in the liter there would be 19999 parts of milk and only 1 part bacteria. The surface area of these bacteria is 3141.6 sq. cm. With this large surface exposed, it is not strange that the change from “on the point of souring” to “sour” occurs within an hour or less.

It is an old belief, and undoubtedly a true one, that milk sours more rapidly during thunder-storms. It is not true that the electricity in the air has anything to do with it. Thunder-storms usually occur during periods of warmer weather. It is the high temperature which warms the milk and this favors more rapid growth of the bacteria. If the milk is kept cool during thunder-storms it will sour no more rapidly than at other times.

Although large numbers of bacteria can and do cause great chemical changes the amount of material actually utilized for maintenance of the cell is very slight, infinitesimal almost, and yet is fairly comparable to that required for man, as is illustrated by the following computations:

E. Kohn has shown that certain water bacteria grew well in water to which there was added per liter 0.000002 mg. dextrose, 0.00000007 mg.  $(\text{NH}_4)_2 \text{SO}_4$  and 0.0000000007 mg.  $(\text{NH}_4)_2 \text{HPO}_4$ . The bacteria numbered about 1000 per cc. Taking the specific gravity at 1 (a little too low) the mass

of the bacteria in the liter was about 0.001 mg. Hence the bacteria used 0.002 of their weight of carbohydrate and 0.00007 of ammonium sulphate. A 150-pound (75-kilo) man can live on 375 g. of sugar (0.005 of his weight) and 52.5 g. of protein (0.0007 of his weight). From these figures it can be calculated that the man utilizes about two and a half times as much carbohydrate and about seven times as much nitrogen as the bacterium, relatively speaking.

**Limitation of Growth.**—Students sometimes get the impression from the discussion in this chapter that a bacterium is immortal, it lives forever. When a bacterium divides an argument might be started as to which of the two, if either,

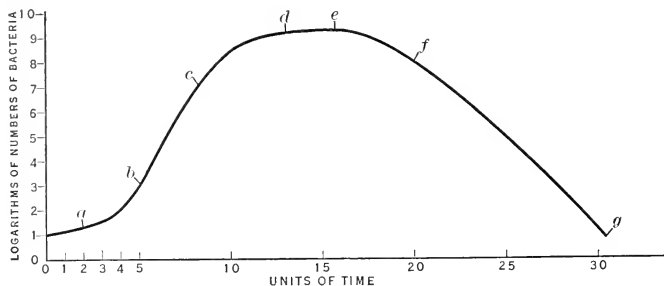

FIG. 52.—The growth curve of bacteria. From "Life Phases in a Bacterial Culture" by R. E. Buchanan, reproduced through the courtesy of the *Journal of Infectious Diseases*.

is the original one. This is like the old discussion as to which came first, the hen or the egg, and need not be followed further. It has been demonstrated that the life of any given bacterium is relatively short. When organisms are placed in a favorable environment, growth, *i. e.*, division proceeds in a very definite manner as is illustrated by Fig. 52. This is a *diagram* illustrating growth rates and not a curve plotted from one single experiment. The diagram means that at first there is a period relatively short during which the organism remains quiet apparently does nothing, *1-a*; then a period of increasing growth rate, *a-b*; next growth at a uniform rate, *b-c*; next decreased growth rate, *c-d*; then a stationary



period when growth and death are equal,  $d-e$ ; increased death-rate,  $e-f$ ; uniform death rate,  $f-g$ ; followed by a slowing down of the death and a stationary or resting period,  $g-$ . The time intervals indicated in this diagram may be hours, days, weeks, etc., depending on the organism, the environment, etc.

The following table adapted from an experiment by Henrici<sup>1</sup> illustrates by numbers the growth and death of bacteria:

I Days of growth.	II Live bacteria.	III Total live and dead.
1	2,790,000,000	2,555,000,000
2	3,650,000,000	3,820,000,000
3	3,200,000,000	4,760,000,000
4	2,265,000,000	5,350,000,000
7	760,000,000	5,760,000,000
10	54,000,000	5,670,000,000
14	8,700,000	5,600,000,000
19	1,610,000	5,380,000,000
25		

A comparison of columns II and III shows the very great diminution, dying out, of the bacteria which begins to be evident in this experiment about the third day.

**Mutation.**—The fundamental reasons why bacteria are expected to *vary with their environment* have been alluded to on page 50. With respect to the chemical environment it is readily apparent that the change which *might be* sufficient to modify the characteristics of a single organism is almost infinitesimal. A coccus  $1\ \mu$  in diameter has a volume of  $0.5236$  by  $10^{-12}$ cc. The actual quantity of any one of the chemical substances present in such an organism, discussed in Chapter VII, or of the elements composing them, could not be detected by any known means. The great variety of so-called "mutations" discussed in the literature of recent years are understandable on the basis of change in the environment, though this, of course, does not *explain why* they should vary. That is still one of the secrets of living substance.

**Life Cycles.**—A number of writers have claimed to see in the changes observed in growing bacteria more or less com-

<sup>1</sup> Henrici, Arthur T.: Morphologic Variation and the Rate of Growth of Bacteria, 1928, p. 170.

plicated "life cycles" comparable to what occurs in higher organisms. Undoubtedly *actively growing* cells are different in appearance from *dying* and *dead* cells. To the interpretation of these differences as illustrations of distinctive "life cycles" the author is sufficiently conservative to apply the Scotch verdict of "not proven." The student especially interested in this phase of bacteriological study is referred to the work of Henrici mentioned on page 75 where he will find not only an excellent discussion but also an extended bibliography of the subject.

**Why Cells Divide.**—Why a single cell should divide, why it does not continually increase in size indefinitely is usually a puzzle to students even to those who are sufficiently advanced to be studying bacteriology. Without entering into a philosophical discussion of all the reasons which might be offered, one fundamental physical explanation only will be pointed out. This applies to cells that get all their food material by diffusion through a cell wall and get rid of their waste in the same way.

The building up of new cell substance, growth of the cell, increase in *volume*, is determined by the amount of food material diffusing through the *surface*. *Volume* of solids increases as the *cube* of any dimension and surface increases as the *square* of the same dimension. Hence volume increases relatively faster than surface and a time in growth will be reached when surface is not sufficient to provide more volume. Division results in increased surface and hence provides for further growth. Division is a growth mechanism. Illustrating the above for a coccus (sphere) to make the calculation simpler the mathematics is as follows:

The actual surface of a sphere is equivalent to four great circles, *i. e.*, is  $4\pi R^2$ . If the sphere divides into two hemispheres each will have one great circle newly exposed. Two new great circles equal  $2\pi R^2$ . Hence  $2\pi R^2$  is added to  $4\pi R^2$  for surface for the same volume. Fifty per cent more surface is available for diffusion of food material into the same volume and each hemisphere can increase to at least the size of the original sphere.

**Growth Accessory Substances.**—Many bacteria are very sensitive to slight environmental changes in reaction, moisture, O tension, temperature; also to the addition or withdrawal of small amounts of chemical substances. Such chemical substances as favor growth are strictly speaking, "growth accessory substances"—hemoglobin for bacteria of the influenza group is a good illustration. Growth accessory substances in the commonly accepted sense of minute quantities of *unknown* chemical substances which markedly affect growth have not, in the author's opinion, been demonstrated with certainty. Extremely careful work to exclude all known substances and conditions which might affect growth must be carried out before one concludes that a growth accessory substance is responsible.

## CHAPTER IX.

### PHYSIOLOGICAL ACTIVITIES.

THE physiological activities of motion, reproduction and metabolism within the cell have been discussed in previous chapters.

The objects in view in the discussion of such physiological activities as are treated in this and subsequent chapters are to familiarize the student to some extent with the great range of chemical changes brought about by these minute organisms, to show their usefulness, even their necessity, and to impress the fact that it is chiefly by a careful study of these "activities" that individual kinds of bacteria are identified. It should always be borne in mind that the bacteria, in bringing about these changes which are so characteristic in many instances, are simply engaged in their own life struggle, in securing the elements which they need for growth, in liberating energy for vital processes, or occasionally in providing conditions which favor their own development and hinder that of their competitors. Most of these changes are incidental to, are by-products of, this life struggle.

Those physiological activities discussed below in which chemical transformations are the pronounced features are frequently termed "biochemical" activities.

#### FERMENTATION OF CARBOHYDRATES.

By this is meant the changes which different carbohydrates undergo when subjected to bacterial action.<sup>1</sup>

These changes are marked chiefly by the production of gas or acid. The former is called "gaseous fermentation" the latter "acid fermentation." The gases commonly pro-

<sup>1</sup> The term "fermentation" was originally used to denote the process which goes on in fruit juices or grain extracts when alcohol and gas are formed. Later it was extended to apply to the decomposition of almost any organic substance. In recent years the attempt has been made to give a chemical definition to the word by restricting its use to those changes in which by virtue of a "wandering" or rearrangement of the carbon atoms

duced are carbon dioxide ( $\text{CO}_2$ ) and hydrogen and marsh gas ( $\text{CH}_4$ ). Other gases of the paraffin series may also be formed as ethane ( $\text{C}_2\text{H}_6$ ), acetylene ( $\text{C}_2\text{H}_2$ ), etc.  $\text{CO}_2$  and  $\text{H}$  are the ones usually formed from sugars by the few gas-forming bacteria which produce disease, though even here some  $\text{CH}_4$  is present. The common *Escherichia coli* forms all three, though the  $\text{CH}_4$  is in smallest quantity.

In the fermentation of the polysaccharids—starch and especially cellulose and woody material—large amounts of  $\text{CH}_4$  occur, particularly when the changes are due to anaërobic bacteria. This phenomenon may be readily observed in sluggish streams, ponds and swamps where vegetable matter accumulates on the bottom. The bubbles of gas which arise when the mass is disturbed explode if a lighted match is applied to them.

The author has conducted a number of experiments to demonstrate this action as follows: Material taken from the bottom of a pond in the fall after vegetation had died out was packed into a cylinder 5 feet long and 6 inches in diameter and water was added to within about 2 inches of the top. After leaving them open for a few days to permit all the dissolved oxygen to be used up by the aërobes, the cylinders were tightly capped and allowed to stand undisturbed. Pressure gauges reading to 500 pounds were attached (Fig. 53). At the end of six months the gauge showed a pressure beyond the limits of the readings on it. Most of the gas was collected and measured 146 liters. An analysis of portions collected when about one-half had been allowed to escape showed the following composition, according to Prof. D. J. Demorest, of the Department of Metallurgy:

$\text{CO}_2$ . . . . .	18.6 per cent.
$\text{CH}_4$ . . . . .	76.1 “
H . . . . .	1.0 “
N . . . . .	4.3 “

Another experiment with a cylinder tested to withstand 5000 pounds per square inch is now under way. The pressure in February, 1929, had reached 750 pounds.

“new substances are formed which are not constituents of the original molecule.” It may be doubted whether this restriction is justified or necessary. A definition is at present scarcely possible except when the qualifying adjective is included as “alcoholic fermentation,” “ammoniacal fermentation,” “lactic acid fermentation,” etc.

In the author's opinion natural gas and petroleum have been formed in this way<sup>1</sup> (Figs. 54 and 55).



FIG. 53.—Cylinder to show the formation of gas by bacteria. The gauge shows 265 pounds. It went beyond 500 pounds.

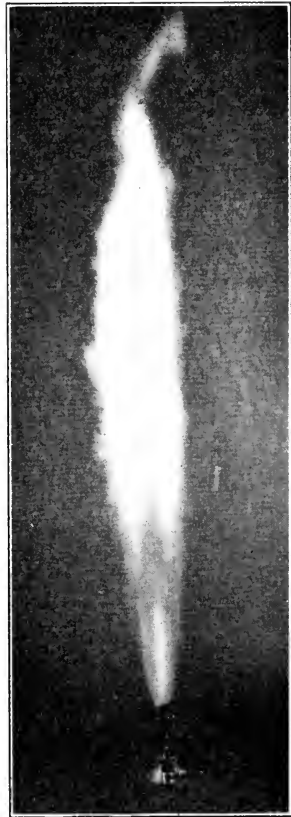

FIG. 54.—A burning natural gas well at night. From a photograph colored.

<sup>1</sup> See "Oil and Gas in Ohio," Bownocker: Geological Survey of Ohio, Fourth Series, Bull. I, pp. 313-314.

One of the very few practical uses of the gaseous fermentation of carbohydrates is in making "salt-rising" bread. The "rising" of the material is due not to yeasts but to the formation of gas by certain bacteria which are present on the cornmeal or flour used in the process (Fig. 56).

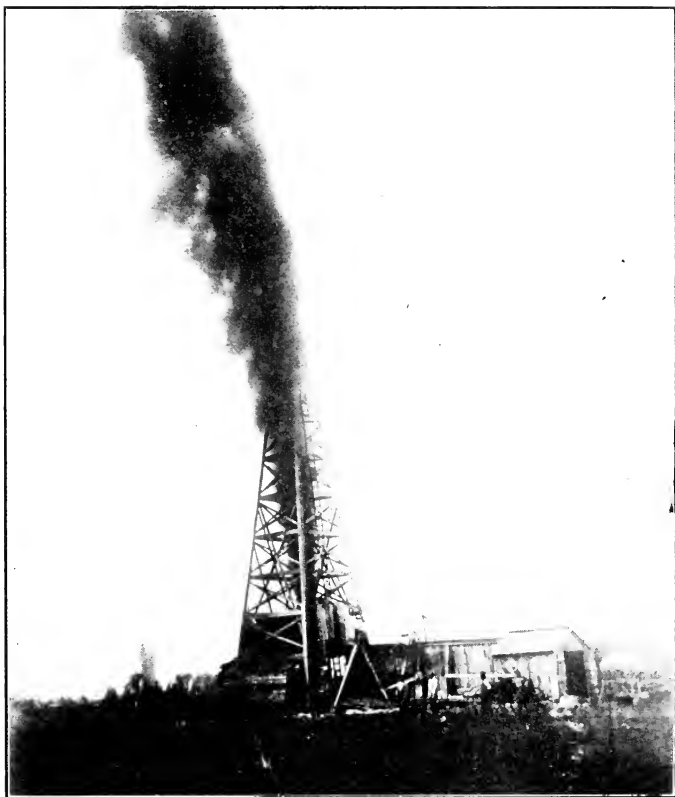

FIG. 55.—A "flowing" oil well.

Another is in the formation of the "holes" or "eyes" so characteristic of Swiss and other types of cheese (Fig. 57).

A great many organic acids are formed during the "acid

fermentation" of carbohydrates by bacteria. Each kind of bacterium, as a rule, forms several different acids as well as

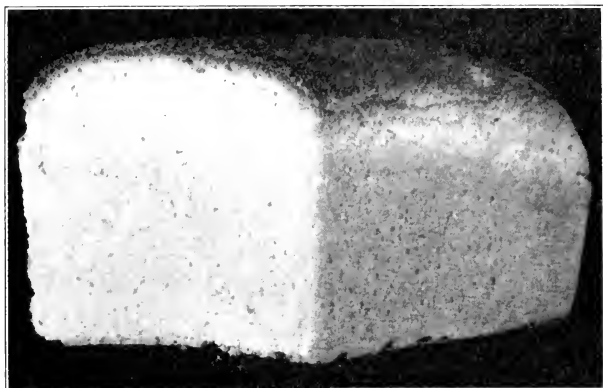

FIG. 56.—A loaf of "salt-rising" bread. The porous structure is due to the gas formed by bacilli and not by yeasts.

other substances, though usually one is produced in much larger amounts, and the kind of fermentation is named from



FIG. 57.—Ohio Swiss cheese. The "eyes" are due to gas formed by bacteria during the ripening of the cheese.

this acid. One of the commonest of these acids is lactic. The "lactic acid bacteria" form a very large and important



group and are indispensable in many commercial processes. In the making of butter the cream is first "ripened," as is the milk from which many kinds of cheese are made (Fig. 58). The chief feature of this "ripening" is the formation of lactic acid from the milk-sugar by the action of bacteria. A similar change occurs in the popular "Bulgarian fermented milk." The reaction is usually represented by the equation:

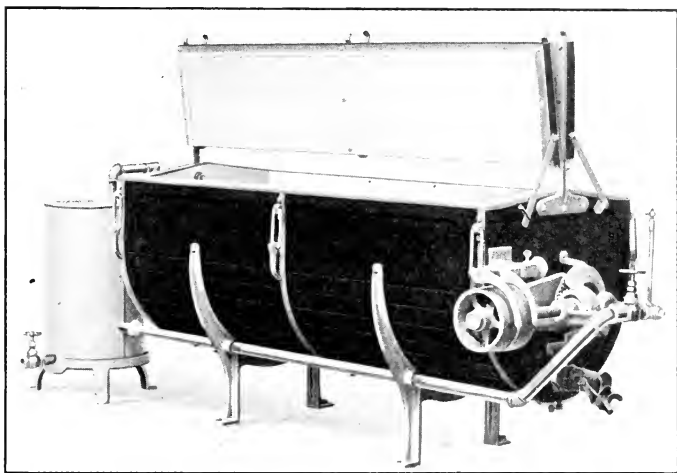
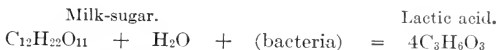

FIG. 58.—A cream ripener. In this apparatus cream is "ripened," *i. e.*, undergoes lactic acid fermentation preparatory to making it into butter.

It is not probable that the change occurs quantitatively as indicated, because a number of other substances are also formed. Some of these are acetic and succinic acids and alcohol. Another industrial use of this acid fermentation is in the preparation of "sauerkraut." These bacteria are chiefly anaerobic and grow best in a relatively high salt concentration. They occur naturally on the cabbage leaves.

In the formation of ensilage (Fig. 59) the lactic acid bacteria play a very important part, as they do also in "sour-

mash" distilling and in many kinds of natural "pickling." In fact, whenever green vegetable material "sours" spontaneously, lactic acid bacteria are always present and account for a large part of the acid. This property of lactic acid formation is also taken advantage of in the preparation of lactic acid on a commercial scale in at least one plant in this country.



FIG. 59.—Filling a silo on the University farm.

Acetic acid is another common product of acid fermentation. However, in vinegar making the acetic acid is not formed directly from the sugar in the fruit juice by bacteria. The sugar is first converted into alcohol by yeasts, then the alcohol is *oxidized* to acid by the bacteria (Fig. 60). The reaction may be represented as follows:

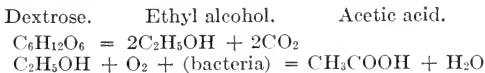

Butyric acid is generally produced where fermentation of carbohydrates occurs under *anaërobic* conditions. Some of

the "strong" odor of certain kinds of cheese is due to this acid, which is formed partly from the milk-sugar remaining in the cheese. Most of it under these conditions comes from the proteins of the cheese and especially from the fat (see page 87).

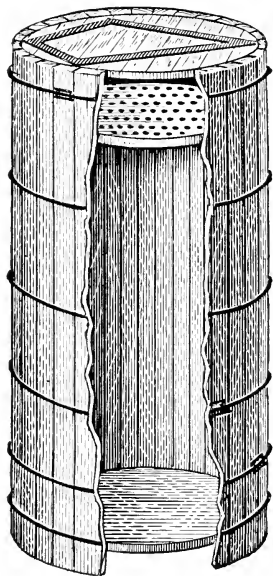

FIG. 60.—A vinegar ripener. The tank shown opened at the side is filled with a special type of beech shavings which thus provide a very large surface. The apple juice which has been previously fermented with yeast, which converts the sugar into alcohol, is allowed to trickle through the openings at the top over the shavings. The acetic acid bacteria on the shavings rapidly oxidizes the alcohol to acetic acid. The vinegar is drawn off below.

As has been indicated alcohol is a common accompaniment of most acid fermentations, as are the esters of acids other than the chief product. Bacteria are not used in a commercial way to produce alcohol, however, as the yield is too small. There are some few bacteria in which the amount of alcohol is prominent enough to call the process an "alcoholic fermentation" rather than an acid one. In brewing and distilling industries, *yeasts* are used to make

the alcohol, though molds replace them in some countries ("sake" and "arrak" from rice).

Under ordinary conditions the carbohydrate is never completely fermented, since the accumulation of the product—acid—stops the reaction. If the acid is neutralized by the addition of an alkali—calcium or magnesium carbonate is best—then the sugar may all be split up. Where such fermentation occurs under natural conditions the products are further split up, partly by molds and partly by acid-destroying bacteria into simpler acids and eventually to carbon dioxide and water, so that the end-products of the complete fermentation of carbohydrate material in nature are carbon dioxide, hydrogen, marsh gas and water.

In all of these fermentations the bacteria are utilizing the *carbon* both as building material and for oxidation, and the fermentations are incidental to this use. As a rule, the acid-forming bacteria can withstand a higher concentration of acid than the other bacteria that would utilize the same material and in a short time crowd out their competitors or inhibit their growth, and thus have better conditions for their own existence, though finally their growth is also checked by the acid.

The best example in the world of the commercial application of "fermentation of carbohydrates" is afforded by the plants of the Commercial Solvents Corporation at Terre Haute, Ind. and Peoria, Ill. Fig. 61 shows a few of their "fermenters," the capacity of each of which is 50,000 gallons. There are 96 of these at Peoria and 52 at Terre Haute. Cheap corn, much of which would otherwise be waste, is used as raw material to the extent of 30,000 bushels per day. The organism which does the fermenting is *Clostridium acetobutylicum* Weizman. The mash used as food for the bacterium is 8 per cent corn in water. Forty thousands gallons are filled into each fermenter. The products recovered are butyl alcohol, acetone, ethyl alcohol, CO<sub>2</sub> and H<sub>2</sub>. The most desirable of these is the butyl alcohol used so largely in "Duco" and similar lacquers for automobiles. The concentration of the liquid products at the end of two and a half days fermentation is 2½ per cent of which 60 per cent is butyl

alcohol, 30 per cent acetone and 10 per cent ethyl alcohol. The hydrogen and about one-half of the  $\text{CO}_2$  are at present converted into methyl alcohol. The total  $\text{CO}_2$  produced equals 6900 tons per month.<sup>1</sup>

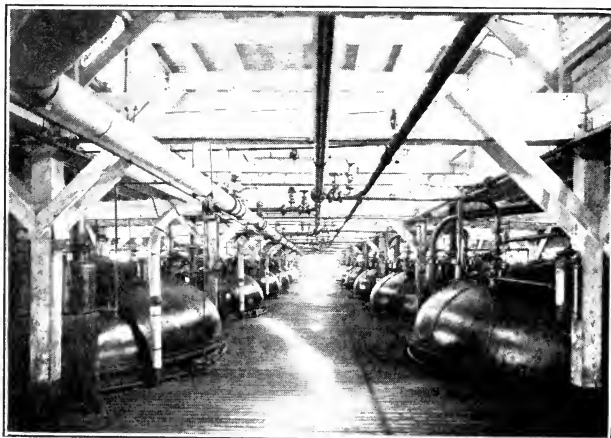
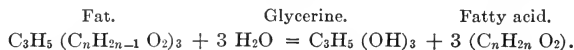

FIG. 61.—A few of the fermenters of the Commercial Solvents Corporation. Reproduced through the courtesy of the Corporation and the Journal of Ind. and Eng. Chemistry.

### SPLITTING OF FATS.

The *splitting of fats* into glycerin and the particular acid or acids involved may be brought about by bacteria. An illustration is the development of rancidity in butter at times and the “strong” odor of animal fats on long keeping, and of many kinds of cheese—“limburger”—in this country. Generally speaking, however, fats are not vigorously attacked, as is illustrated by the difficulties due to accumulation of fats in certain types of sewage-disposal works. The chemical change is represented by the equation:



<sup>1</sup> Journal of Industrial and Engineering Chemistry, 1927, **19**, 45; 1927, p. 1147; 1928, **20**, 1063.

The failure of bacteria to decompose fats rapidly is probably not to be ascribed to any peculiar difficulty of such dissociation. It is due rather to the fact that fats generally occur in Nature in rather large accumulations and hence free from the elements that bacteria require for growth. The elements C, H, O are not sufficient. The other nine must be available. Every buttermaker knows that thoroughly washed butter keeps longer. The washing removes the nitrogenous and other substances that bacteria need and hence inhibits their growth.

## CHAPTER X.

### PHYSIOLOGICAL ACTIVITIES (CONTINUED).

#### PUTREFACTION OF PROTEINS.

THE word "*putrefaction*" is now restricted to the action of bacteria on the *complex nitrogen-containing substances*, proteins, and their immediate derivatives. The process is usually accompanied by the development of foul odors.

Bacteria make use of proteins chiefly as a source of nitrogen, but also as a source of carbon and other elements. Proteins contain nitrogen, carbon, hydrogen, oxygen, sulphur and frequently phosphorus. Some of the metals—potassium, sodium, calcium, magnesium, iron and manganese and the non-metal chlorine—are nearly always associated with them more or less intimately. Since these bodies are the most complex of natural chemical substances it follows that the breaking up of the molecule to secure a part of the nitrogen gives rise to a great variety of products.

There are marked differences among bacteria in their ability to attack this class of compounds. Some can break up the most complex natural proteins such as albumins, globulins, glyco-, chromo- and nucleoproteins, nucleins and albuminoid derivatives like gelatin. The term *saprogenic* (*σαπρως*, *sapros* = rotten) is sometimes applied to bacteria which have this power. These proteins are large-moleculed and not diffusible, so that the first splitting up that they undergo must occur outside the bacterial cell. The products of this first splitting may diffuse into the cell and be utilized there. The bacteria of this class attack not only these proteins in the natural state or in solution, but also in the coagulated state. The coagulum becomes softened and finally changed into a liquid condition. The process when applied to the casein of milk is usually called "digestion," also when coagulated blood serum is acted on. In the latter case the

serum is more commonly said to be "liquefied," as is the case when gelatin is the substance changed. Most of these bacteria have also the property of coagulating or curdling milk in an alkaline medium and then digesting the curd. A second class of bacteria has no effect on the complex proteins just mentioned but readily attacks the products of their first splitting, *i. e.*, the proteoses, peptones, polypeptides and amino-acids. They are sometimes called *saprophylic* bacteria.

Other bacteria derive their nitrogen from some of the products of the first two groups and still further break down the complex protein molecule. Under normal conditions these various kinds of bacteria all occur together and thus mutually assist one another in what is equivalent to a symbiosis or rather a metabiosis, a "successive existence," one set living on the products of the other. The result is the complete splitting up of the protein molecule. A part of the nitrogen is built up into the bodies of the bacteria which are using it as food. A part is finally liberated as *free nitrogen* or as *ammonia* after having undergone a series of transformations, many of which are still undetermined.

One class of compounds formed received at one time much attention because they were supposed to be responsible for a great deal of illness. These are the "ptomaines," basic nitrogen compounds of definite composition—amines—some few of which are poisonous, most of them not. The basic character of ptomaines may be understood if they be regarded as made up of one or more molecules of ammonia in which the hydrogen has been replaced by alkyl or other radicals. Thus ammonia (NH)<sub>3</sub> may be represented as

$$\begin{array}{c} \text{H} \\ \diagup \\ \text{N} - \text{H} \\ \diagdown \\ \text{H} \end{array}$$
 The simplest ptomaine is 
$$\begin{array}{c} \text{CH}_3 \\ \diagup \\ \text{N} - \text{H} \\ \diagdown \\ \text{H} \end{array}$$
 in which one H is replaced by methyl, methylamine, a gaseous ptomaine.

With two hydrogens replaced by methyl, 
$$\begin{array}{c} \text{CH}_3 \\ \diagup \\ \text{N} - \text{CH}_3 \\ \diagdown \\ \text{H} \end{array}$$
 dimethylamine, also a gas at ordinary temperature, is formed. Trimethylamine, 
$$\begin{array}{c} \text{CH}_3 \\ \diagup \\ \text{N} - \text{CH}_3 \\ \diagdown \\ \text{CH}_3 \end{array}$$
 a liquid, results when three hydro-



gens are similarly replaced. All three of these occur in herring brine and are responsible for the characteristic odor of this material. Putrescin and cadaverin—tetramethylenediamine and pentamethylenediamine respectively—occur generally in decomposing flesh, hence the names. They are only slightly poisonous. One of the highly poisonous ptomaines is neurin  $C_3H_{13}NO$  or  $C_2H_2N(CH_3)_3OH$  = trimethyl-vinyl ammonium hydroxide. This is a stronger base than ammonia, liberating it from its salts. Numerous other ptomaines have been isolated and described. These bodies were considered for a long time to be the cause of various kinds of "meat poisoning," "ice-cream poisoning," "cheese poisoning," etc. It is true that they may sometimes cause these conditions, but they are very much rarer than the laity generally believe. Most of the "meat poisonings" in America are due not to ptomaines, but to infections with certain bacilli of the *Salmonella* group. Occasionally a case of poisoning by the true toxin (see Chapter XII) of *Clostridium botulinum* occurs, and in recent years has become entirely too common, due to insufficient heating of canned goods. *The boiling of such material will destroy this toxin. The safest rule to follow is not to eat any canned material that shows any departure from the normal in flavor, taste or consistency.*

As ptomaines result from the putrefaction of proteins, so they are still further decomposed by bacteria, and eventually the nitrogen is liberated either as free nitrogen or as ammonia.

Another series of products are the so-called aromatic compounds—phenol (carbolic acid), various cresols, also indol and skatol or methyl indol (these two are largely responsible for the characteristic odor of human feces). All of these nitrogen compounds are attacked by bacteria and the nitrogen is eventually liberated, so far as it is not locked up in the bodies of the bacteria, as free nitrogen or as ammonia.

The carbon which occurs in proteins accompanies the nitrogen in many of the above products, but also appears in nitrogen-free organic acids, aldehydes and alcohols which are all eventually split up, so that the carbon is changed

to carbon dioxide or in the absence of oxygen partly to marsh gas.

The intermediate changes which the sulphur in proteins undergoes are not known, but it is liberated as sulphuretted hydrogen ( $H_2S$ ) or as various mercaptans (all foul-smelling), or is partially oxidized to sulphuric acid. Some of the  $H_2S$  and the sulphur of the mercaptans are oxidized by the sulphur bacteria to free sulphur and finally to sulphuric acid.

Phosphorus is present especially in the nucleoproteins and nucleins. Just what the intermediate stages are, or whether there are any, so far as the phosphorus is concerned, in the splitting up of nucleic acid by bacterial action is not determined. The phosphorus may occur as phosphoric acid in such decompositions, or when the conditions are anaërobic as phosphine ( $PH_3$ ), which burns spontaneously in the air to phosphorus pentoxide ( $P_2O_5$ ) and water.<sup>1</sup>

The hydrogen in proteins appears in the forms above indicated:  $H_4C$ ,  $H_3N$ ,  $H_3P$ ,  $H_2S$ ,  $H_2O$  and as free H. The oxygen as  $CO_2$  and  $H_2O$ .

In the breaking down of the complex protein molecule even by a single kind of bacterium there is not a perfect descending scale of complexity as might be supposed from the statement that there result proteoses, peptones, polypeptids and amino-acids. These substances do result, but at the time of their formation simpler ones are formed also, even  $CO_2$ ,  $NH_3$  and  $H_2S$ . It appears that the entire molecule is shattered in such a way that less complex proteins are formed from the major part, while a minor portion breaks up completely to the simplest combinations possible. A more complete knowledge of these decompositions will aid in the further unravelling of the structure of proteins. The presence or absence of free oxygen makes a difference in the end-products, as has been indicated. There are bacteria which oxidize the ammonia to nitric acid and the  $H_2S$  to sulphuric acid. (See Oxidation, Chapter XI.) Bacteria

<sup>1</sup> It is probable that this is the way "Jack o'lanterns" or "Will o' the wisps" are ignited. Marsh gas is produced as above outlined from the vegetable and animal matter decomposing in swampy places under anaërobic conditions and likewise phosphine. These escape into the air and the "spontaneous combustion" of the phosphine ignites the marsh gas.

which directly oxidize phosphorus compounds to phosphoric acid have not been described. It does not seem that such are necessary, since this is either split off from nucleic acid or results from the spontaneous oxidation of phosphine when this is formed under anaërobic conditions.

Not only are proteins decomposed as above outlined, but also their waste products, that is, the form in which their nitrogen leaves the animal body. This is largely urea in mammals, with much hippuric acid in herbivorous animals and uric acid in birds and reptiles. These substances yield  $\text{NH}_3$ ,  $\text{CO}_2$  and  $\text{H}_2\text{O}$  with a variety of organic acids as intermediate products in some cases. The strong odor of ammonia in stables and about manure piles is the every-day evidence of this decomposition.

Where the putrefaction of proteins occurs in the soil with moderate amounts of moisture and free access of air a large part of the products is retained in the soil. Thus the ammonia and carbon dioxide in the presence of water form ammonium carbonate; the nitric, sulphuric and phosphoric acids unite with some of the metals which are always present to form salts. Some of the gases do escape, and most where the oxygen supply is least, since they are not oxidized.

The protein-splitting reactions afford valuable tests in aiding in the recognition of bacteria. In the study of pathogenic bacteria the coagulation and digestion of milk, the digestion or liquefaction of blood serum, the liquefaction of gelatin and the production of indol and  $\text{H}_2\text{S}$  are those usually tested for. In dairy bacteriology the coagulation of milk and the digestion of the casein are common phenomena. Most bacteria which liquefy gelatin also digest blood serum and coagulate and digest milk, though there are exceptions. In soil bacteriology the whole range of protein changes is of the greatest importance.

The three physiological activities already discussed explain how bacteria break down the chief complex, energy-rich substances—carbohydrates, fats and proteins which constitute the bulk of the organic material in the bodies of plants and animals, as well as the waste products of the latter—into energy-free compounds like carbon dioxide, water, ammonia, nitric, sulphuric and phosphoric acids—

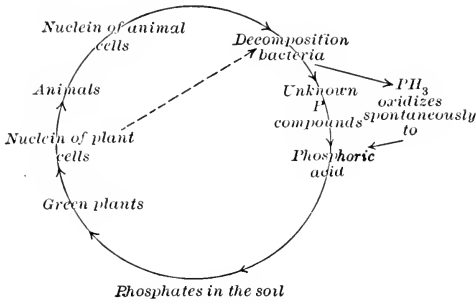

FIG. 62.—Diagram to illustrate the circulation of phosphorus through the agency of bacteria.

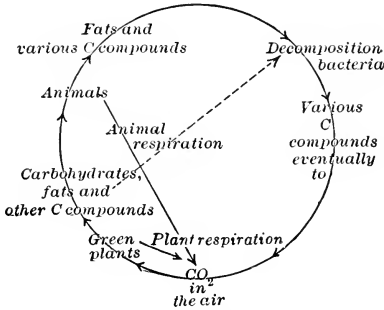

FIG. 63.—Diagram to illustrate the circulation of carbon through the agency of bacteria.

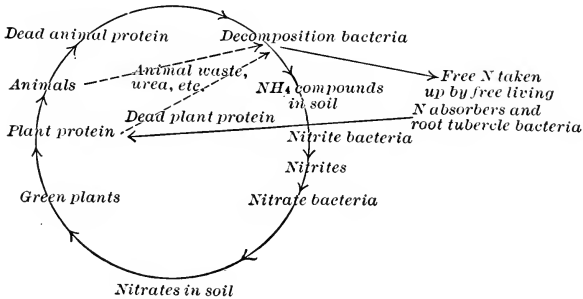

FIG. 64—Diagram to illustrate the circulation of nitrogen through the agency of bacteria.

mineralize them, as is frequently said. By so doing the bacteria act as the great scavengers of Nature removing the dead animal and vegetable matter of all kinds which but for this action would accumulate to such an extent that all life, both on land and in the water, must cease. It is further to be noted that not only is all this dead organic matter removed, but it is converted into forms which are again available for plant growth. Carbon dioxide forms the source of the carbon in all green plants, hence in all animals; the sulphates and phosphates are likewise taken up by green plants and built up again into protein compounds; the ammonia is not directly available to green plants to any

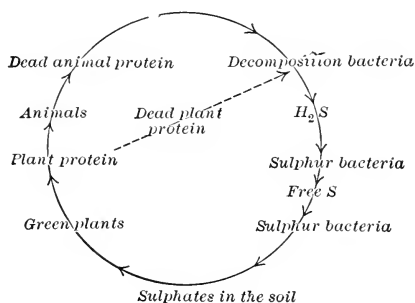

FIG. 65.—Diagram to illustrate the circulation of sulphur through the agency of bacteria.

large extent but is converted by the nitrifying bacteria (Chapter XI) into nitrates, which is the form in which nitrogen is assimilated by these higher types. Even the free nitrogen of the air is taken up by several kinds of bacteria, the symbiotic "root-tubercle bacteria" of leguminous and other plants and some free-living forms, and made available. Hence bacteria are indispensable in Nature, especially in keeping up the circulation of nitrogen. They are also of great service in the circulation of carbon, sulphur and phosphorus. Though some few kinds cause disease in man and animals, if it were not for the saprophytic bacteria above outlined there could be no animals and higher plants to acquire these diseases.

## CHAPTER XI.

### PHYSIOLOGICAL ACTIVITIES (CONTINUED).

#### PRODUCTION OF ACIDS.

THE production of organic acids has been sufficiently discussed in preceding chapters. It should be noted that not only these in great variety are produced by bacteria but that under certain conditions mineral acids, such as nitric, sulphuric and phosphoric, may be formed (see Oxidation, page 100). Acid production is of great value in the identification of bacteria in dairy and soil work and in connection with certain types of pathogenic bacteria.

#### GAS PRODUCTION.

It will be sufficient merely to enumerate collectively the various gases mentioned in preceding paragraphs and to state that those commonly observed in the study of pathogenic bacteria are the first six mentioned. Most of them come in in dairy work either in the study of bacteria causing milk and cheese "failures" or as affecting the flavors of butter or cheese. In the study of soil organisms, any or all of them are liable to be of importance. The gases are:  $\text{CO}_2$ , H,  $\text{CH}_4$ , N,  $\text{NH}_3$ ,  $\text{H}_2\text{S}$ , gaseous mercaptans, gaseous ptomaines, volatile fatty acids, ethereal salts or esters and others, both of pleasant and of foul odor, but of unknown composition.

#### PRODUCTION OF ESTERS.

The production of esters, as mentioned in Chapters IX and X, of various alcohols and aldehydes are activities which are sometimes of value in the study of bacteria, but need not be further discussed.

**PRODUCTION OF "AROMATIC" COMPOUNDS.**

These have been mentioned in discussing the putrefaction of proteins, as indol, skatol, phenol and various cresols. Of these only the first is ordinarily tested for in the study of bacteria, though others of the group become of value in certain special cases.

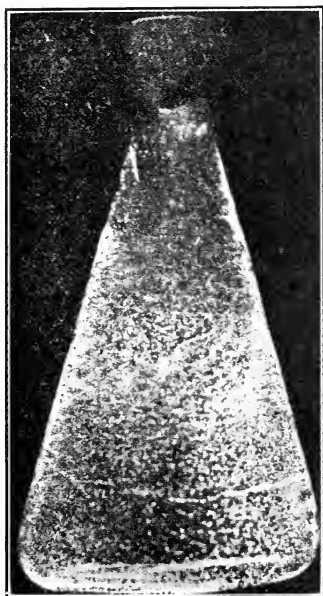

FIG. 66.—Culture of phosphorescent bacteria in an Ehrlenmeyer flask photographed by their own light. Time of exposure twelve hours. (Molisch from Lafar.)

**PHOSPHORESCENCE OR PHOTOGENESIS.**

This is a most interesting phenomenon associated with the growth of some bacteria. The "fox fire" frequently seen on decaying wood which is covered with a slimy deposit is most commonly due to bacteria, though also to other fungi. Phosphorescent bacteria are very common in sea water,

hence they are frequently found on various sea foods, especially when these are allowed to decompose, such as fish, oysters, clams, etc. The light is due to the conversion of the energy of unknown easily oxidizable compounds directly into *visible* radiant energy through oxidation without appreciable quantities of heat. The light produced may be sufficient to tell the time on a watch in absolute darkness, and also to photograph the growths with their own light, but only after several hours exposure (Fig. 66). None of the phosphorescent bacteria so far discovered produce disease in the higher animals or man.

### PRODUCTION OF PIGMENT OR CHROMOGENESIS.

One of the most striking results of bacterial activity is this phenomenon. The particular color which results may be almost any one throughout the range of the spectrum, though shades of yellow and of red are of more frequent occurrence.

In the red sulphur bacteria the "bacterio-purpurin" which they contain appears to serve as a true respiratory pigment in a manner similar to the chlorophyl in green plants, except that these bacteria oxidize  $H_2S$  in the light as a source of energy instead of splitting up  $CO_2$ . The red pigment produced by certain bacteria has been shown to have a capacity for combining with O resembling that of hemoglobin, and some investigators have believed that such bacteria do store O in this way for use when the supply is diminished. With these few exceptions the pigments seem to be merely by-products of cell activity which are colored and have no known function.

The red sulphur bacteria above mentioned and one or two other kinds retain the pigments formed within the cell. Such bacteria are called *chromophoric* as distinguished from the *chromoparic* bacteria whose pigment lies outside the cell.

The chemical composition of no bacterial pigment has been determined up to the present. Some are soluble in water, as shown by the discoloration of the substances on which they grow. Others are not soluble in water but are



in alcohol, or in some of the fat solvents as ether, chloroform, benzol, etc. These latter are probably closely related to the *lipochromes* or "fat colors" of higher plants and animals. Attempts have been made to render the production of pigments a still more reliable means of identification of species of bacteria through a careful examination of the spectra of their solutions, but such study has not as yet led to any valuable practical results.

The production of pigment depends on the same general factors which determine the growth of the organism but does *not necessarily run parallel* with these. It is especially influenced by the oxygen supply (only a very few organisms are known which produce pigment anaerobically—*Spirillum rubrum* is one); by the presence of certain food substances (starch, as in potato, for many bacteria producing yellow and red colors; certain mineral salts, as phosphates and sulphates, for others); by the temperature (many bacteria cease to produce color at all if grown at body temperature, 37°—*Serratia marcescens*—or if grown for a longer time at temperatures a few degrees higher).

### REDUCING ACTIONS.

Reduction of nitrates to nitrites or to ammonia or even to free nitrogen is brought about by a great many different kinds of bacteria. In many instances this phenomenon is due to a lack of free oxygen, which is obtained by the bacteria from these easily reducible salts. In other cases a portion of the nitrogen is removed to be used as food material in the building up of new protein in the bacterial cell. This latter use of the nitrogen of nitrates by bacteria might theoretically result in considerable loss of "available nitrogen" in the soil, as has actually been shown in a few experiments. The reduction of nitrates as above mentioned would also diminish this supply, but probably neither of these results has any very great practical effect on soil fertility. The building up of protein from these mineral salts by bacteria in the intestines of herbivorous animals has been

suggested by Armsby as a considerable source of nitrogenous food, and this suggestion appears possible.

The liberation of nitrogen from nitrates or nitrites, either as free nitrogen or as ammonia, is spoken of as "denitrification," though this term was formerly applied to such liberations from compounds of nitrogen generally, even from proteins.

Certain bacteria may also reduce sulphates and other sulphur compounds to  $H_2S$ , a phenomenon frequently observed in sewage and likewise of importance in the soil. It is possible that phosphates may be similarly reduced.<sup>1</sup> Further and more careful study of the reducing actions of bacteria is needed.

### OXIDATION.

As has been stated in discussing the respiration of bacteria (Chapter VIII) most of these organisms gain their energy through the oxidation of carbon in various forms, chiefly organic, so that  $CO_2$  is a product of the activity of nearly all bacteria. Some few oxidize CO to  $CO_2$ , others  $CH_4$  and other paraffins to  $CO_2$  for this purpose. One class of bacteria even oxidizes H in small amounts for its energy and uses the carbon dioxide of the air or traces of organic carbon in the air as a source of carbon for "building" purposes.

One of the familiar oxidations of organic carbon is that of the acetic acid bacteria in the making of vinegar. These oxidize the alcohol which results from the action of yeast to acetic acid according to the formula  $CH_3CH_2OH + O_2 = CH_3COOH + H_2O$  (see Fig. 60).

Of the various phenomena of oxidation due to bacteria, the formation of nitrites and nitrates has the greatest practical importance, since it is by this means that the ammonia which results from the decomposition of animal and vegetable tissue and waste products is again rendered available to green plants as food in the form of nitrates. Practically all the nitrates found in Nature, sometimes in large quanti-

<sup>1</sup> Dr. H. H. Green, of Pretoria, South Africa, has isolated from "cattle dips" a bacterium that *reduces arsenates to arsenites*.

ties, are formed in this way. There are two distinct kinds of bacteria involved. One, the nitrous bacteria, oxidizes the ammonia to nitrous acid which forms nitrites with bases, and the other, the nitric bacteria, oxidizes the nitrous to nitric acid, giving nitrates with bases. A striking peculiarity of these two classes of organisms is that they may live entirely on inorganic food materials, are proto-autotrophic, prototrophic for oxygen (aërobic) and autotrophic for the

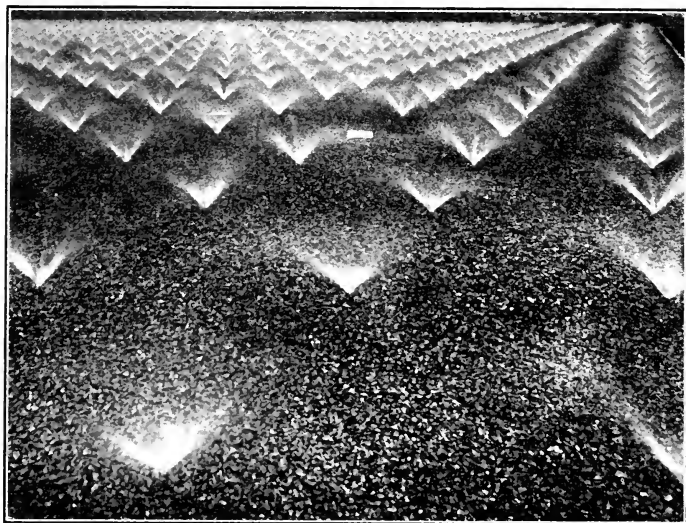

FIG. 67.—Sprinkling filters of the Columbus sewage-disposal plant—devices which provide a good supply of oxygen for the bacteria that oxidize the organic matter in the sewage.

other elements. Their carbon is derived from  $\text{CO}_2$  or carbonates. The importance of such organisms in keeping up the supply of nitrates in the soil can scarcely be overestimated.

The oxidation of the  $\text{H}_2\text{S}$ , which is formed in the putrefaction of proteins, to free S by the sulphur bacteria and the further oxidation of this free S to sulphuric acid, and of the phosphorus, so characteristic of the nucleins, to phosphoric

acid, have been referred to. These activities of bacteria are of great value in the soil. Doubtless the commercial "phosphate rock" owes its origin to similar bacterial action in ages past.

The oxidation of  $H_2S$  to free S may be an explanation of the origin of the great deposits of sulphur which are found in Louisiana and along the Gulf coast. These deposits occur in the same general regions as natural gas and oil. The sulphur might have been derived from the same organic material carried down by the Mississippi, which yielded the oil and gas.<sup>1</sup>

A purposeful utilization of the oxidizing power of bacteria is in "contact beds," "sprinkling filters" and "aërated sludge tanks" in sewage-disposal works. In these instances the sewage is thoroughly mixed with air and brought in contact with large amounts of porous material so as to expose an extensive surface for oxidation (Fig. 67).



FIG. 68.—One of the University hot-beds.

### PRODUCTION OF HEAT.

A direct result of the oxidizing action of bacteria is the production of heat. Under most conditions of bacterial growth this heat is not appreciable. It may become well marked. The "heating" of manure is one of the commonest

<sup>1</sup> Dr. Green (l. c.) has also isolated an organism which causes some deterioration of cattle dips by oxidizing arsenites to arsenates.

illustrations. The temperature in such cases may reach 70°. The heating of hay and other green materials is due chiefly to bacterial action. This heating may lead to "spontaneous combustion." The high temperatures (60° to 70°) favor the growth of thermophil bacteria, which cause a still further rise. The heat dries out the material, portions of which are in a state of very fine division, due to the disintegrating action of the organisms. The hot, dry, finely divided material oxidizes so rapidly on contact with the air that it ignites.

A practical use of heat production by bacteria is in the making of "hot-beds" for forcing vegetables (Fig. 68).

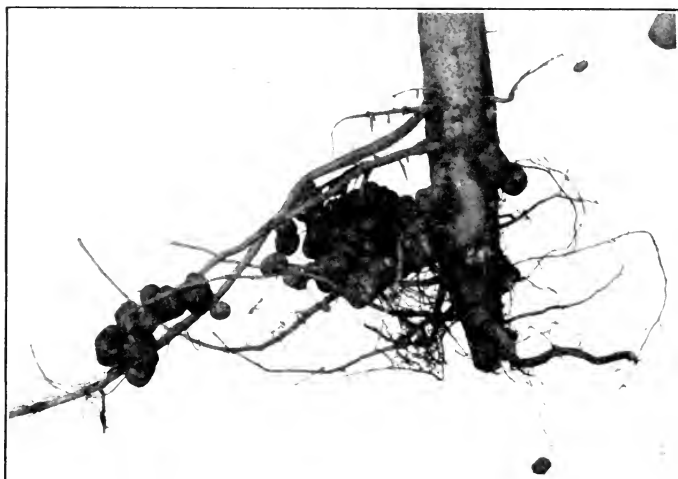

FIG. 69.—Root tubercles on soy bean.  $\times \frac{3}{2}$ .

### ABSORPTION OF FREE NITROGEN.

This is likewise one of the most important practical activities of certain types of bacteria present in the soil. The ability of plants of the legume family to enrich the soil has been known and taken advantage of for centuries, but it is only about thirty years since it was demonstrated

that this property is due to bacteria. These plants, and several other kinds as well, have on their roots larger or smaller nodules (Fig. 69), spoken of as "root tubercles," which are at certain stages filled with bacteria. When conditions are favorable, these bacteria live in symbiotic relationship with the plant tissues, receiving carbonaceous and other food material from them and in return furnishing nitrogenous compounds to the plant. This nitrogenous material is built up from free nitrogen absorbed from the air by the bacteria. The utilization of this peculiar property through the proper cultivation of clover, alfalfa, soy beans and other legumes is one of the best ways of building up and maintaining soil fertility in so far as the nitrogen is concerned. The technical name of these bacteria is *Rhizobium leguminosarum*.

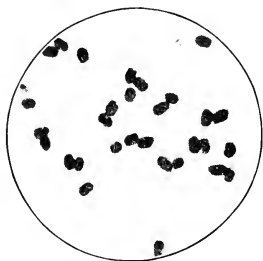

FIG. 70.—Free-living nitrogen absorbing bacteria "Azotobacter." Note their large size as compared with other bacteria shown in this book.

There are also types of "free-living" as distinguished from these symbiotic bacteria which absorb the free nitrogen of the air and aid materially in keeping up this supply under natural conditions. One of the most important of these types is the aërobic "Azotobacter" (Fig. 70), while another is the anaërobic *Clostridium pasteurianum*. The nitrogen which is absorbed is built up into the protein material of the cell body, and this latter must in all probability be "worked over" by various types of decomposition bacteria and by the nitrous and nitric organisms and be converted into utilizable nitrates just as other protein

material is, as has been discussed in Chapter X. At any rate, there is as yet no definite knowledge of any other method of transformation. Up to the present no intentional practical utilization of this valuable property of these free-living forms has been made.

**Nitrogen Nutrition of Green Plants.**—It is the belief of botanists that green plants obtain their nitrogen chiefly in the form of nitrates, though ammonium salts may be utilized to some extent by certain plants at least. Exceptions to this general rule are those plants provided with root tubercles (and the bog plants and others which have mycorrhiza). These plants obtain their nitrogen in the form of organic compounds made for them by the bacteria growing in the tubercles. That nitrogen circulates throughout the structure of plants in organic combination is certain. There does not appear to be any reason why similar compounds which are soluble and diffusible (amino-acids) should not be taken up through the roots of plants and utilized as such. *It seems to the author that this is very probably the case.* Arguments in favor of this view are: (1) The nitrogen nutrition of leguminous and other plants with root nodules. (2) The close symbiosis between "Azotobacter" and similar nitrogen-absorbing bacteria and many species of algae in sea water at least. (3) The vigorous growth of plants in soils very rich in organic matter. This inhibits the production of nitrates by the nitrous nitric bacteria when grown in culture. It probably does so in the soil, so that nitrates may not account for the vigorous growth. (4) The effect of nitrate fertilizers is to add an amount of nitrogen to the crop much in excess of the amount added as nitrate. (5) The most fertile soils contain the largest numbers of bacteria. The doctrine that nitrates furnish the only nitrogen to plants was established before the activities of bacteria in the soil were suspected, and, so far as the author is aware, has not been supported by experiments under conditions rigidly controlled as to sterility.

It would seem that one of the chief functions of soil bacteria is to prepare soluble organic compounds of nitrogen for the use of green plants and thus to make a "short cut"

in the nitrogen cycle (page 94), as now believed in, direct from the "decomposition bacteria" to green plants.

Experiments have been made by different observers in growing seedling plants of various kinds in water culture with one or in some cases several of the amino-acids as sources of nitrogen. Most of these experiments were disappointing. Plant proteins are not so different from animal proteins or plant protoplasm (apart from the chlorophyll portions of plants) from animal protoplasm as to lead one to suppose that it could be built up from one or two amino-acids any more than animal protoplasm can. The author is strongly convinced that this subject should be thoroughly investigated. It will require careful experimentation and perhaps rather large funds to provide the amounts of amino-acids that would probably be needed, but might result in a decided change in our ideas of soil fertility, and especially in the use of nitrogen fertilizers.



## CHAPTER XII.

### PHYSIOLOGICAL ACTIVITIES (CONTINUED).

#### PRODUCTION OF ENZYMES.

MOST of the physiological activities of bacteria which have been discussed are due to the action of these peculiar substances, so that a knowledge of their properties is essential. This knowledge cannot as yet be exact because no enzyme has, up to the present, been obtained in a "pure state," though it must be admitted that there are no certain criteria which will enable this "pure state" to be recognized.<sup>1</sup> It was formerly thought that they were protein in nature, but very "pure" and active enzymes have been prepared which did not give the characteristic protein reactions, so this idea must be abandoned. That they are large moleculcd colloidal substances closely related to the proteins in many respects must still be maintained. There are certain characteristics which belong to enzymes, though no one of them exclusively. These may be enumerated as follows:

1. Enzymes are *dead* organic chemical substances.

*Dead* is used in the sense of non-living, never having lived, not in the sense of "ceased to be alive."

2. They are always produced by *living cells*:

Sometimes as active enzymes, sometimes as *pro-enzymes* or *zymogens* which are converted into enzymes outside the cell by acids, other inorganic substances or other enzymes.

<sup>1</sup> Dr. Carl C. Warden, of the University of Michigan, published an article in the *Am. Jour. of Physiol.*, October, 1921, **57**, p. 434 et seq., in which he states that sodium oleate distributed over finely ground fibrin, or even pieces of porous crockery, acted exactly like the enzyme of yeast in converting dextrose into CO<sub>2</sub> and alcohol. He seems to have made an artificial enzyme and to have shown that so-called enzymes are of simple chemical composition but are held in a colloidal state in living matter. This work needs to be confirmed.

3. They produce very great chemical changes without themselves being appreciably affected.

Enzymes will not continue to act indefinitely but are used up in the process (combination with products). The amount of change is so great in proportion to the amount of enzyme that the above statement is justified in the relative sense. Thus a milk-curdling enzyme has been prepared that would precipitate 100,000,000 times its own weight of caseinogen.

4. Their action is specific in that each enzyme acts on one kind of chemical substance only, and the products are always the same.

The substance may be combined with a variety of other chemical substances so that the action appears to be on several, but in reality it is on a definite group of molecules in each instance. For example, emulsin attacks several different glucosides but always sets free dextrose from them.

5. The action is inhibited and eventually stopped, and in some cases the enzyme is destroyed by an accumulation of the products of the action. If the products are removed the action will continue if the enzyme is not destroyed. This effect is explained partly because the enzyme probably combines with some of the products, since it does not act indefinitely, and partly because of the reversibility of the reaction.

6. Like many chemical reactions those of enzymes are reversible, that is, the substance broken up may be reformed by it from the products produced in many instances. Thus:

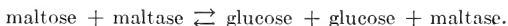

7. The presence of certain mineral salts seems to be essential for their action. These and other substances which are necessary are sometimes called *co-enzymes*. A salt of calcium is most favorable for a great many.

8. They may be adsorbed like other colloids by "shaking out" with finely divided suspensions like charcoal or kaolin, or by other colloids like aluminum hydroxide or proteins.

9. When properly introduced into the tissues or blood of an animal, they cause the body cells to form *anti-enzymes*, which will prevent the action of the enzyme (see Chapter XXVII).

10. Though inert, they show many of the characteristics of living organisms, that is—

(a) Each enzyme has an optimum, a maximum and a minimum temperature for its action.

All chemical reactions have such temperature limits, the distinction is that for enzymes as for living substance the *range* is relatively narrow.

(b) High temperatures destroy enzymes. All in water are destroyed by boiling in time and most at temperatures considerably below the boiling-point. When dry, many will withstand a higher degree of heat than 100° before they are destroyed.

(c) Temperatures below the minimum stop their action, though they are not destroyed by cold.

(d) Many poisons and chemical disinfectants (Chapter XIV) which kill living organisms will also stop the action of enzymes, though generally more of the substance is required, so that it is possible to destroy the living cells by such means and yet the action of the enzyme will continue.

(e) Most enzymes have an optimum reaction of medium, either acid, alkaline or neutral, depending on the particular enzyme, though some few seem to act equally well within a considerable range on either side of the neutral point.

*The final test for an enzyme is the chemical change it brings about in the specific substance acted on.*

The most prominent characteristic of enzymes is that they bring about very great chemical changes without themselves being appreciably affected. This property is also shown by many inorganic substances which are spoken of as “catalytic agents” or “catalyzers,” so that enzymes are sometimes called “organic catalyzers.” The function of catalytic agents seems to be to hasten the rate of a reaction which would occur spontaneously, though in a great many cases with extreme slowness.

Just how enzymes act is not certain and probably will not

be until their composition and constitution are known. Most probably they form a combination with the substance acted on (*the substrate*) as a result of which there is a rearrangement of the atoms in such a way that new compounds are formed, nearly always at least two, and the enzyme is at the same time set free. It is rather remarkable that chiefly optically active substances are split up by enzymes, and where two modifications exist it is usually the dextro-rotatory one which is attacked. No single enzyme attacks both. This probably means that the structure of the enzyme corresponds to that of the substrate, "fits it as a key fits a lock," as Emil Fischer says.

The production of enzymes is by no means restricted to bacteria, since all kinds of living cells that have been investigated have been shown to produce them and presumably *all* living cells do. Hence the number of different kinds of enzymes and of substances acted upon is practically unlimited. Nevertheless they may be grouped into a comparatively few classes based on the general character of the change brought about by them.

I. Class I is the so-called "*splitting*" *enzymes* whose action is for the most part hydrolytic, that is, the substance takes up water and then splits into compounds that were apparently constituents of the original molecule. As examples may be mentioned *diastase*, the enzyme first discovered, which changes starch into a malt-sugar, hence is more commonly called *amylase*<sup>1</sup> (starch-splitting enzyme); *invertase*<sup>1</sup>, which splits cane-sugar into dextrose and levulose:  $C_{12}H_{22}O_{11} + H_2O = C_6H_{12}O_6 + C_6H_{12}O_6$ . *Lipase*<sup>1</sup>, or a fat-splitting enzyme, which decomposes fat into glycerin and fatty acid:  $C_3H_5(OC_nH_{2n-1}O)_3 + 3H_2O = C_3H_5(OH)_3 + 3C_nH_{2n}O_2$ .

Fat.

Glycerin.

Fatty acid.

*Proteases*, which split up proteins into proteoses and peptones.

Other classes of "splitting enzymes" break up the prod-

<sup>1</sup> It will be noted that the names of enzymes (except some of those first discovered) terminate in *ase*, which is usually added to the *stem of the name of the substance acted on*, though sometimes to a word which indicates the substance formed by the action, as *lactacidase*, *alcoholase*.

ucts of complex protein decomposition, such as proteoses, peptones and amino-acids. A variety of the "splitting enzymes" is the group of—

"*Coagulases*," or *coagulating enzymes*, as the rennet (lab, chymosin) which curdles milk and fibrin ferment (thrombin, thrombase) which causes the coagulation of blood. These apparently act by splitting up a substance in the fluids mentioned, after which splitting one of the new products formed combines with other compounds present (usually a mineral salt, and in the cases mentioned a calcium salt) to form an insoluble compound, the curd or coagulum.

Another variety is the "*activating*" enzymes or "*kinases*," such as the enterokinase of the intestine. The action here is a splitting of the *zymogen* or mother substance or form in which the enzyme is built up by the cell so as to liberate the active enzyme.

Of a character quite distinct from the splitting enzymes are:

II. The *zymases*. Their action seems to be to cause a "shifting on rearrangement of the carbon atoms" so that new compounds are formed which are not assumed to have been constituents of the original molecule. Most commonly there is a closer combination of the carbon and oxygen atoms, frequently even the formation of  $\text{CO}_2$ , so that considerable energy is thus liberated. Examples are the *zymase* or *alcoholase* of yeast, which converts sugar into alcohol and carbon dioxide:  $\text{C}_6\text{H}_{12}\text{O}_6 = 2\text{C}_2\text{H}_6\text{O} + 2\text{CO}_2$ ; also *urease*, which causes the change of urea into ammonia and carbon dioxide. Another common zymase is the *lactacidase* in lactic acid fermentation.

III. *Oxidizing enzymes* also play an important part in many of the activities of higher plants and animals. Among the bacteria this action is illustrated by the formation of nitrites, nitrates and sulphates and the oxidation of alcohol to acetic acid, as already described.

IV. *Reducing enzymes* occur in many of the dentrifying bacteria and in those which liberate  $\text{H}_2\text{S}$  from sulphates. A very widely distributed reducing enzyme is "catalase," which decomposes hydrogen peroxide.

As previously stated, most of the physiological activities of bacteria are due to the enzymes that they produce. It is evident that for action to occur on substances which do not diffuse into the bacterial cell—starches, cellulose, complex proteins, gelatin—the enzymes must *pass out* of the bacterium and consequently may be found in the surrounding medium. Substances like sugars, peptones, alcohol, which are readily diffusible, may be acted on by enzymes *retained within* the cell body. In the former case the enzymes are spoken of as extracellular or “*exoenzymes*,” and in the latter as intracellular or “*endoenzymes*.” The endoenzymes and doubtless also the exoenzymes may after the death of the cell digest the contents to a greater or less extent and thus furnish substances that are not otherwise obtainable. This process of “self-digestion” is known technically as “autolysis.”

A distinction was formerly made between “organized” and “unorganized ferments.” The former term was applied to the minute living organisms, bacteria, yeasts, molds, etc., which bring about characteristic fermentative changes, while the latter term was restricted to enzymes as just described. Since investigation has shown that the changes ascribed to the “organized ferments” are really due to their enzymes, and that enzymes are probably formed by all living cells, the distinction is scarcely necessary at present.

### PRODUCTION OF TOXINS.

The injurious effects of pathogenic bacteria are due in large part to the action of these substances, which in many respects bear a close relationship to enzymes. The chemical composition is unknown since no toxin has been prepared “pure” as yet. It was formerly thought that they were protein in character, but very pure toxins have been prepared which failed to show the characteristic protein reactions.<sup>1</sup> It is well established that they are complex sub-

<sup>1</sup> Dr. Warden (page 107) claims that the toxin of the diphtheria bacillus at least is a relatively simple *fat complex* in a colloidal state. He has prepared *artificial* fat complexes which have the same properties.

stances of rather large molecule and are precipitated by many of the reagents which precipitate proteins. Toxins will be further discussed in Chapter XXVII. It will be sufficient at this point to enumerate their chief peculiarities in order to show their marked resemblance to enzymes.

1. Toxins are *dead* organic chemical substances.
2. They are always produced by *living* cells.
3. They are active poisons in *very small quantities*.<sup>1</sup>
4. Their action is specific in that each toxin acts on a particular kind of cell. The fact that a so-called toxin acts on several different kinds of cells possibly indicates a mixture of several toxins, or action on the *same substance* in the cells.

5. Toxins are very sensitive to the action of injurious agencies such as heat, light, etc., and in about the same measure that enzymes are, though, as a rule, they are somewhat more sensitive or "labile."

6. Toxins apparently have maxima, optima and minima of temperature for their action, as shown by the destructive effect of heat and by the fact that a frog injected with tetanus toxin and kept at 20° shows no indication of poison; but if the temperature is raised to 37°, symptoms of poisoning are soon apparent. Cold, however, does not destroy a toxin.

7. When properly introduced into the tissues of animals they cause the body cells to form antitoxins (Chapter XXVII), which are capable of preventing the action of the toxin in question.

8. *The determining test for a toxin is its action on a living cell.*

It is true that enzymes are toxic, as are also various foreign proteins, when injected into an animal, but in much larger doses than are toxins.

A marked difference between enzymes and toxins is that the former may bring about a very great chemical change and still may be recovered from the mixture of substances acted on and produced, while the toxin seems to be perma-

<sup>1</sup>Tetanus toxin is about 120 times as poisonous as strychnin, both of which act on the same kind of nerve cells.

nently used up in its toxic action and cannot be so recovered. *Toxins seem very much like enzymes whose action is restricted to living cells.*

Just as enzymes are probably produced by all kinds of cells and not by bacteria alone, so toxins are produced by other organisms. Among toxins which have been carefully studied are *ricin*, the poison of the castor oil plant (*Ricinus communis*); *abrin* of the jequirity bean (*Abrus precatorius*); *robin* of the common locust (*Robinia pseudacacia*); poisons of spiders, scorpions, bees, fish, snakes and salamanders.

It has been stated that some enzymes are thrown out from the cell and others are retained within the cell. The same is true of toxins, hence we speak of *exotoxins* or toxins excreted from and *endotoxins* or toxins retained within the cell. Among the pathogenic bacteria there are very few which secrete toxins when growing outside the body. *Clostridium tetani* or lockjaw bacillus, *Corynebacterium diphtheriæ* or the diphtheria bacillus, *Clostridium botulinum* or a bacillus causing a type of food poisoning, *Pseudomonas æruginosa* or the blue pus bacillus are the most important. Other pathogenic bacteria do not secrete their toxins under the above conditions, but give them up only when the cell is disintegrated either within or outside the body. For the reason that endotoxins are therefore difficult to obtain, their characteristics have not been much studied. The description of toxins as above given is intended to apply to the *exotoxins* of bacteria, sometimes spoken of as *true toxins*, and to the vegetable toxins (phytotoxins) which resemble them.

The snake venoms and probably most of the animal toxins (zoötoxins) are very different substances. (See Chapter XXIX.)

### CAUSATION OF DISEASE.

This subject belongs properly in special pathogenic bacteriology. It will be sufficient to indicate that bacteria may cause disease in one or more of the following ways: (a) Blocking circulatory vessels, either blood or lymph, directly or indirectly; (b) destruction of tissue; (c) production of



non-specific poisons (ptomaines, bases, nitrites, acids, gases, etc.); (d) production of specific poisons (toxins).

### **ANTIBODY FORMATION.**

Bacteria cause the formation of specific "antibodies" when properly introduced into animals. This must be considered as a physiological activity, since it is by means of substances produced within the bacterial cell that the body cells of animals are stimulated to form antibodies. (See Chapters XXVI-XXIX.)

### **STAINING.**

The reaction of bacteria to various stains is dependent on their physico-chemical structure and hence is a result of physiological processes, but is best discussed separately (Chapter XIX).

### **CULTURAL CHARACTERISTICS.**

The same is true of the appearance and growth on different culture media (Chapter XX).

## CHAPTER XIII.

### DISINFECTION—STERILIZATION—DISINFECTANTS.

THE discussion of the physiology of bacteria in the preceding chapters has shown that a number of environmental factors must be properly correlated in order that a given organism may thrive. Conversely it can be stated that any one of the environmental factors may be so varied that the organism will be more or less injured and may even be destroyed by such variation. It has been the thorough study of the above-mentioned relationships which has led to practical methods for destroying bacteria, for removing them or preventing their growth when such procedures become necessary.

The process of killing all the living organisms or of removing them completely is spoken of as *disinfection* or as *sterilization*, according to circumstances. Thus the latter term is applied largely in the laboratory, while the former more generally in practice outside the laboratory. So also disinfection is most commonly done with chemical agents and sterilization by physical means, though exceptions are numerous. The original idea of disinfection was the destruction of "infective" organisms, that is, organisms producing disease in man or animals. A wider knowledge of bacteriology has led to the application of the term to the destruction of other organisms as well. Thus the cheesemaker "disinfects" his curing rooms to prevent abnormal ripening of cheese, and the dairyworker "disinfects" his premises to avoid bad flavors, abnormal changes in the butter or milk. *Sterilization* is more commonly applied to relatively small objects and *disinfection* to larger ones. Thus in the laboratory, instruments, glassware, apparatus, etc., are "sterilized"

while desks, walls and floors are "disinfected." The surgeon "sterilizes" his instruments but "disinfects" his operating table and room. The dairyworkers mentioned above sterilize their apparatus, pails, milk bottles, etc. Evidently the object of the two processes is the same, removing or destroying live organisms; the name to be applied is largely a question of usage and circumstances. Any agent which is used to destroy microorganisms is called a "disinfectant." Material freed from *living* organisms is "sterile."

The process of *preventing the growth* of organisms without reference to whether they are killed or removed is spoken of as "*antiseptis*," and the agent as an *antiseptic*. Hence a mildly applied "disinfectant" becomes an "antiseptic," though it does not necessarily follow that an "antiseptic" may become a disinfectant when used abundantly. Thus strong sugar solutions prevent the development of many organisms, though they do not necessarily kill them.

*Asepsis* is a term which is restricted almost entirely to surgical operations and implies the taking of such precautions that foreign organisms are *kept out* of the field of operation. Such an operation is an *aseptic* one, or performed *aseptically*.

A "deodorant or deodorizer" is used to destroy or remove an odor and does not necessarily have either antiseptic or disinfectant properties.

The agents which are used for the above-described processes may be conveniently divided into *physical agents* and *chemical agents*.

### PHYSICAL AGENTS.

1. **Drying.**—This is doubtless the oldest method for *preventing the growth of* organisms, and the one which is used on the greatest amount of material at the present time. A very large percentage of commercial products is preserved and transported intact because the substances are kept free from moisture. In the laboratory many materials which are used as food for bacteria (see Chapter XVI) "keep" because they are dry. Nevertheless, drying should be con-

sidered as an *antiseptic* rather than as a *disinfectant* process. While it is true that the *complete* removal of water would result in the death of all organisms, this necessitates a high temperature, in itself destructive, and does not occur in practice. Further, though many pathogenic bacteria are killed by drying, many more, including the spore formers, are not. Hence drying alone is not a practical method of *disinfecting*.

2. **Heat.**—The use of heat in some form is one of the very best means for destroying bacteria. It may be made

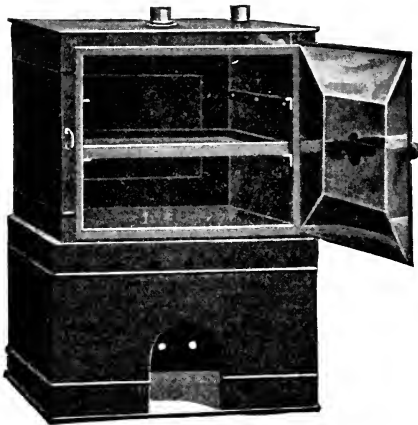

FIG. 71.—A small laboratory hot-air sterilizer.

use of by combustion, or burning, as direct exposure to the open flame, as dry heat (hot air), or as moist heat (boiling water or steam). Very frequently in veterinary practice, especially in the country, occasionally under other conditions, the infected material is best burned. This method is thoroughly effective and frequently the cheapest in the end. Wherever there are no valid objections it should be used. Exposure to the open flame is largely a laboratory procedure to sterilize small metallic instruments and even small pieces of glassware. It is an excellent procedure in postmortem examinations to burn off the surface of the body or of an

organ when it is desired to obtain bacteria from the interior free from contamination with surface organisms.

*Dry Heat.*—Dry heat is not nearly so effective as moist heat as a sterilizing agent. The temperature must be higher and continued longer to accomplish the same result. Thus a dry heat of  $150^{\circ}$  for thirty minutes is no more efficient than steam under pressure at  $115^{\circ}$  for fifteen minutes. Various forms of hot-air sterilizers are made for laboratory purposes (Fig. 71). On account of the greater length of time required for sterilization their use is more and more restricted to objects which must be used dry, as in blood and serum work, for example. In practice the use of hot air in disinfecting plants is now largely restricted to objects which might be injured by steam, as leather goods, furs, and certain articles of furniture, but even here chemical agents are more frequently used.

*Moist Heat.*—Moist heat may be applied either by boiling in water or by the use of steam at air pressure, or, for rapid work and on substances that would not be injured, by steam under pressure. Boiling is perhaps the best household method for disinfecting all material which can be so treated. The method is simple, can always be made use of, and is universally understood. It must be remembered that all pathogenic organisms, even their spores, are destroyed by a few minutes' boiling. The process may be applied to more resistant organisms, such as are met with in canning vegetables, though the boiling must be continued for several hours, or what is better, repeated on several different days. This latter process, known as "*discontinuous sterilization*," or "*tyndallization*," must also be applied to substances which would be injured or changed in composition by too long-continued heating, such as gelatin, milk and certain sugars. In the laboratory such materials are boiled or subjected to streaming steam for half an hour on each of three successive days. In canning vegetables the boiling should be from one or two hours each day. The principle involved is that the first boiling destroys the growing cells, but not all spores. Some of the latter germinate by the next day and are then killed by the second boiling and the remainder

develop and are killed on the third day. Occasionally a fourth boiling is necessary. It is also true that repeated heating and cooling are more destructive to bacteria than continuous heating for the same length of time, but the development of the spores is the more important factor. Discontinuous heating may also be used at temperatures below the boiling-point for the sterilization of fluids like blood serum, which would be coagulated by boiling. In this case the material is heated at  $55^{\circ}$  to  $56^{\circ}$  for one hour, but on each of seven to ten successive days. The intermittent heating and cooling is of the same importance as the development of the spores in this case. (Better results are secured with such substances by collecting them aseptically in the first place.)

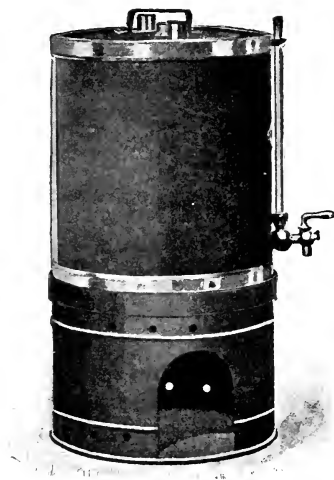

FIG. 72.—The Arnold steam sterilizer for laboratory use.

*Steam.*—Steam is one of the most commonly employed agents for sterilization and disinfection. It is used either as “streaming steam” at air pressure or confined under pressure so that the temperature is raised. For almost all purposes where boiling is applicable streaming steam may

be substituted. It is just as efficient and frequently more easily applied. The principle of the numerous forms of "steam sterilizers" (Fig. 72) is essentially the same. There

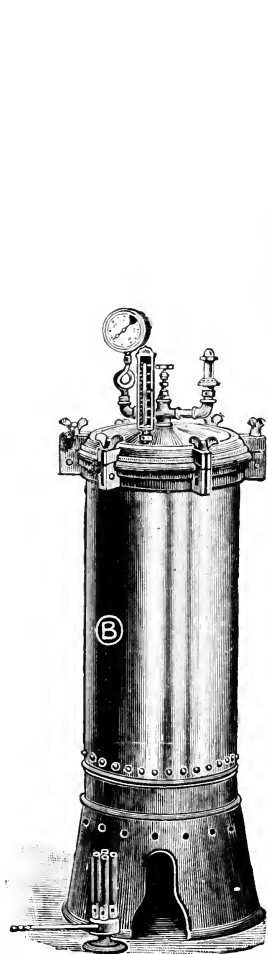

FIG. 73.—Vertical gas-heated laboratory autoclave.

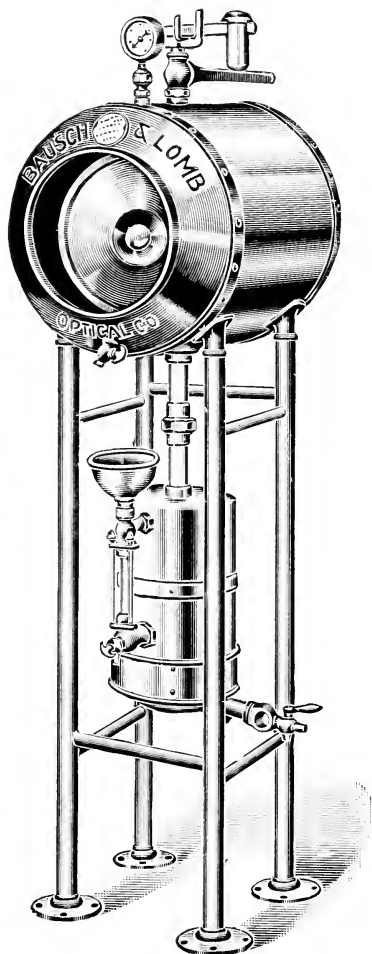

FIG. 74.—Horizontal gas-heated laboratory autoclave.

is a receptacle for a relatively small quantity of water and means for conducting the steam generated by boiling this water to the objects to be treated, which are usually placed immediately above the water. Surgical instruments may be most conveniently sterilized by boiling or by steaming in especially constructed instrument sterilizers. If boiled the addition of carbonate of soda, about 1 per cent, usually prevents injury.

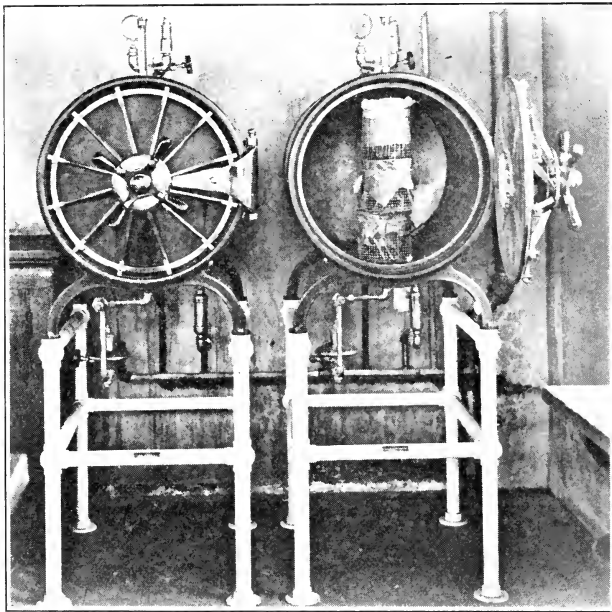

FIG. 75.—A battery of two horizontal autoclaves in one of the author's student laboratories. Steam is furnished direct from the University central heating plant.

*Steam under pressure* affords a much more rapid and certain method of destroying organisms. Fifteen to twenty pounds pressure corresponding to temperatures of  $121^{\circ}$  to  $125^{\circ}$  is commonly used. Variations depend on the bulk and



nature of the material. Apparatus for this purpose may now be obtained from sizes as small as one or two gallons up to huge structures which will take one or two truckloads of material (Figs. 73-85). The latter type is in common use in canning factories, dairy plants, hospitals, public institutions and municipal and governmental disinfecting stations. Very frequently there is an apparatus attached for pro-



FIG. 76.—A “process kettle” (steam-pressure sterilizer) used in canning  
Diameter, 40 inches; height, 72 inches.

ducing a vacuum both to exhaust the air before sterilizing, so that the steam penetrates much more quickly and thoroughly, and for removing the vapor after sterilizing, thus hastening the drying out of the material disinfected.

The smaller types of pressure sterilizers are called “autoclaves” and have become indispensable in laboratory work. Fifteen pounds’ pressure maintained for fifteen minutes is commonly sufficient for a few small objects. For larger masses much longer time is needed. The author found that

in an autoclave of the type shown in Fig. 74 it required ten minutes for 500 cc of water at 15 pounds' pressure to reach a temperature of 100°, starting at room temperatures, 20° to 25°. Autoclaves may be used as simple steam sterilizers by

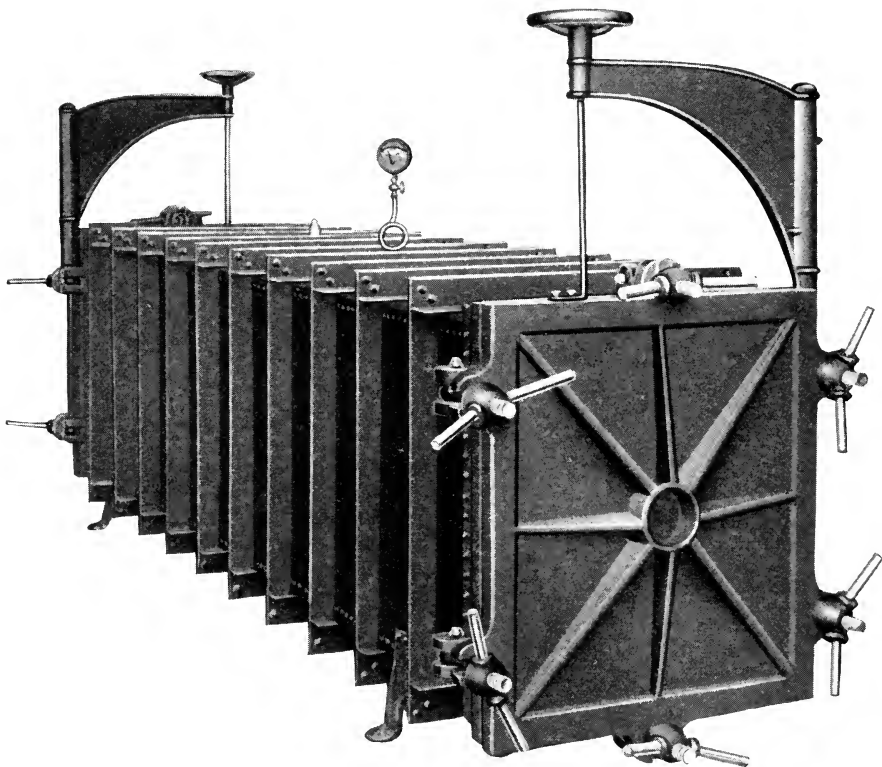

FIG. 77.—Horizontal steam chest used in canning. Height, 32 inches; width, 28 inches; length, 10 feet.

leaving the escape valves open so that the steam is not confined, hence they have largely replaced the latter.<sup>1</sup>

<sup>1</sup> In the author's laboratory all sterilization except those few objects in blood and serum work which must be dry, is done in autoclaves of the type shown in Fig. 75, which are supplied with steam from the University central heating plant. A very great saving of time is thus secured.

A process closely akin to sterilization by heat is *pasteurization*. This means the heating of material at a tempera-

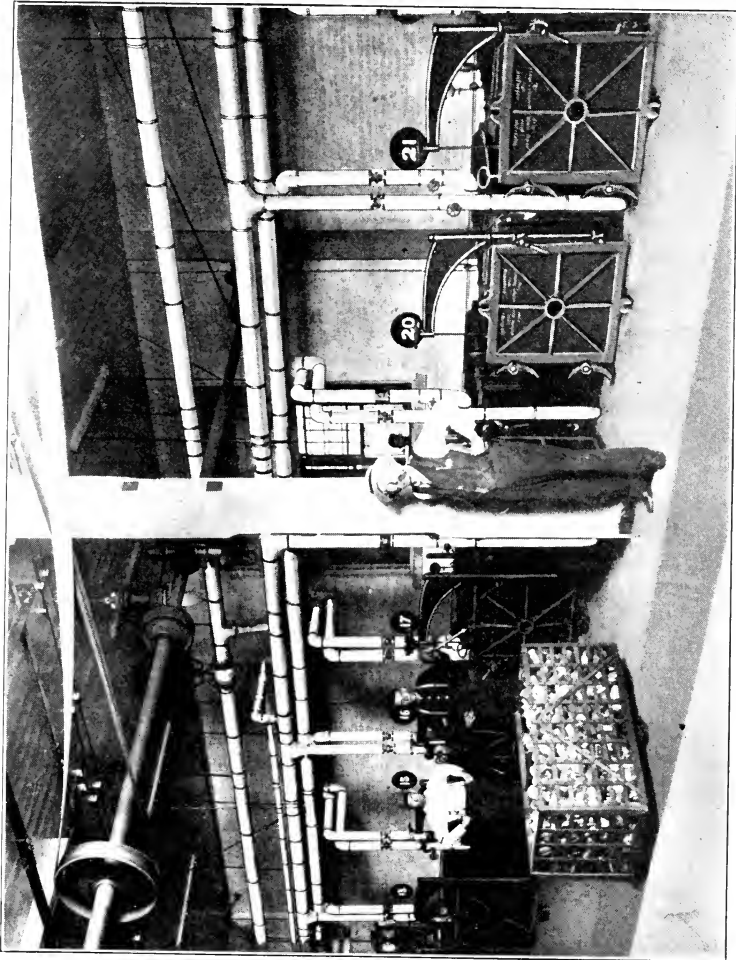

FIG. 78 — A battery of horizontal rectangular steam chests in actual use in a canning factory.

ture and for a time which will destroy the actively growing bacteria but not the spores. The methods for doing this

vary but are essentially two in principle. 1. The material in small quantities in suitable containers (bottles) is placed

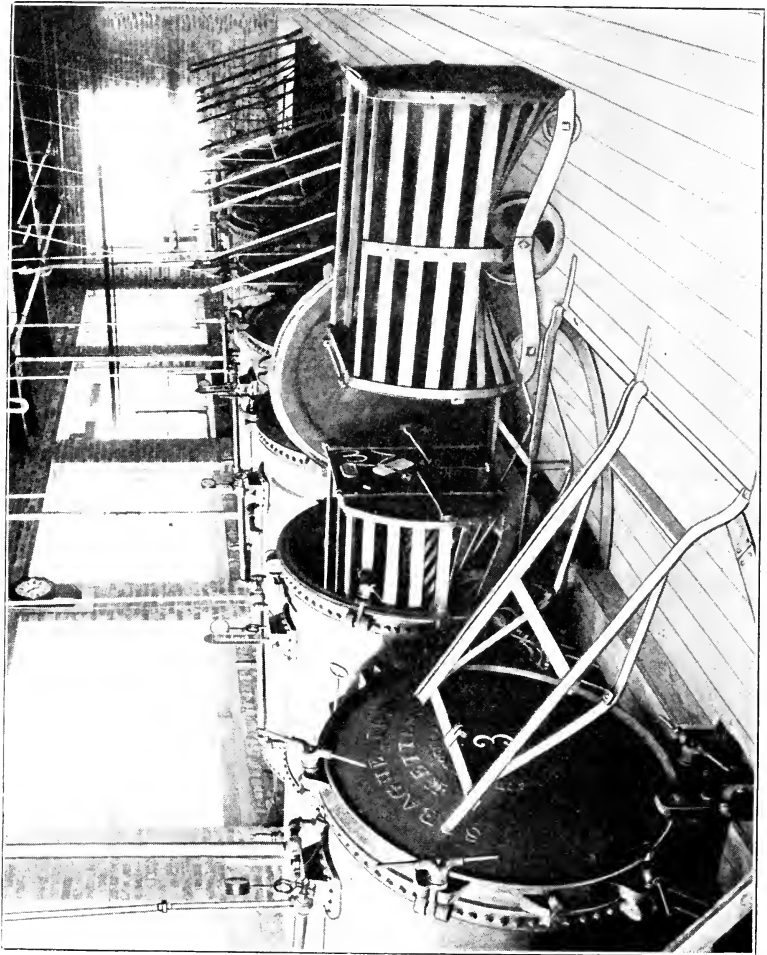

Fig. 79.—A battery of cylindrical process kettles in actual use in a canning factory.

in the apparatus; the temperature is raised to  $60^{\circ}$  to  $65^{\circ}$  and maintained for twenty to thirty minutes and then the

whole is cooled (beer, wine, grape juice, bottled milk) (Figs. 86, 87, 88).

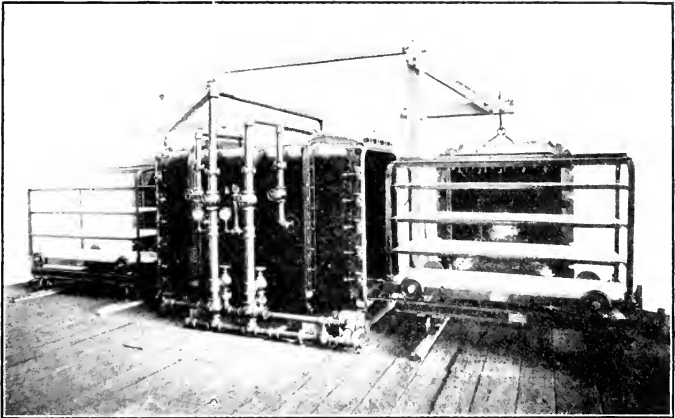

FIG. 80.—A steam chamber used in government disinfection work. Size 4 feet 4 inches x 5 feet 4 inches x 9 feet.

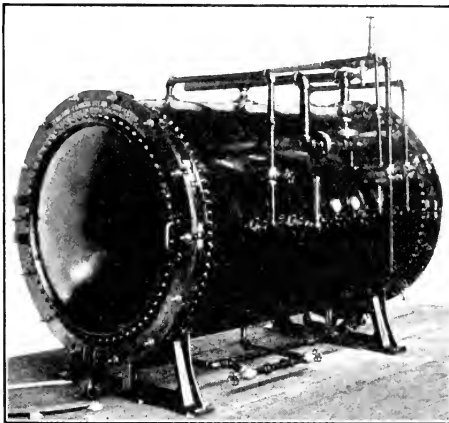

FIG. 81.—Circular steam chamber used in government disinfection work, 54 inches in diameter.

2. Pasteurizing machines are used and the fluid flows through continuously. In one type the temperature is

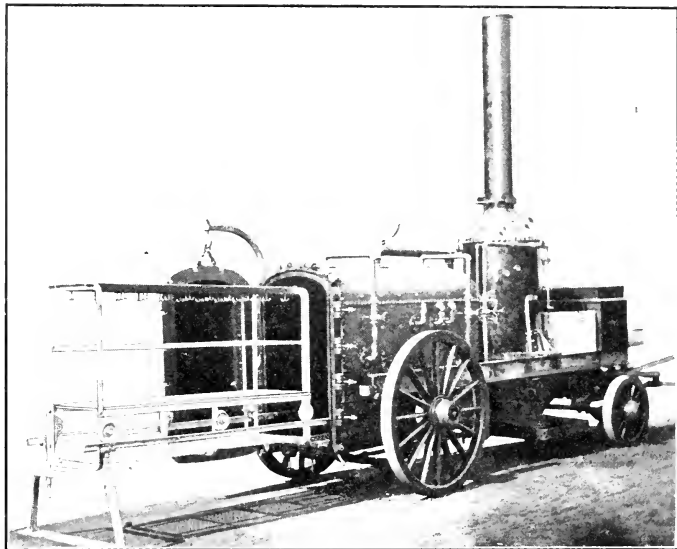

FIG. 82.—Portable steam chamber used in government disinfection work.

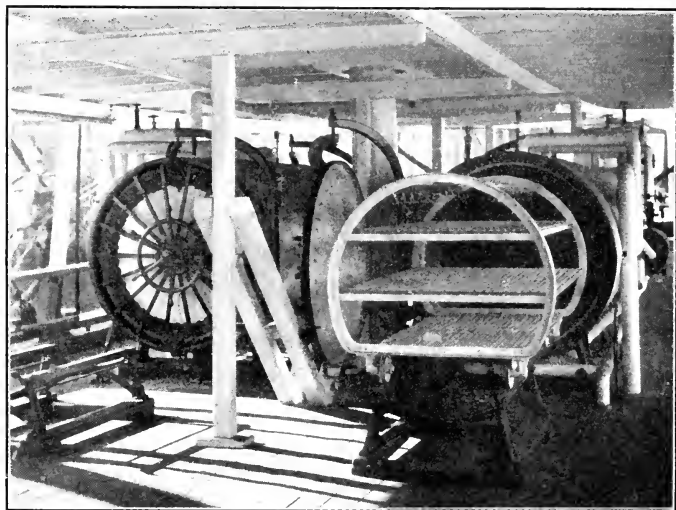

FIG. 83.—Steam chambers on deck of the U. S. quarantine station barge "Defender."

raised to 60° and by "retarders" is kept at this temperature for twenty to thirty minutes (Figs. 89 to 92). In another

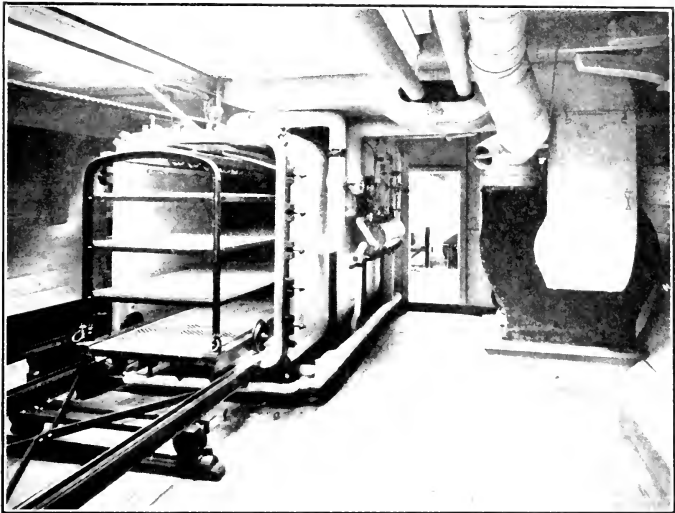

FIG. 84.—Steam chambers in hold of U. S. quarantine station barge "Protector." Disinfected space.

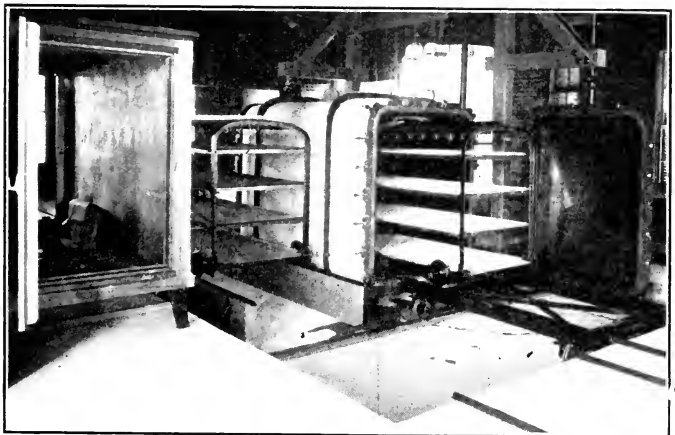

FIG. 85.—Municipal disinfecting station, Washington, D. C.

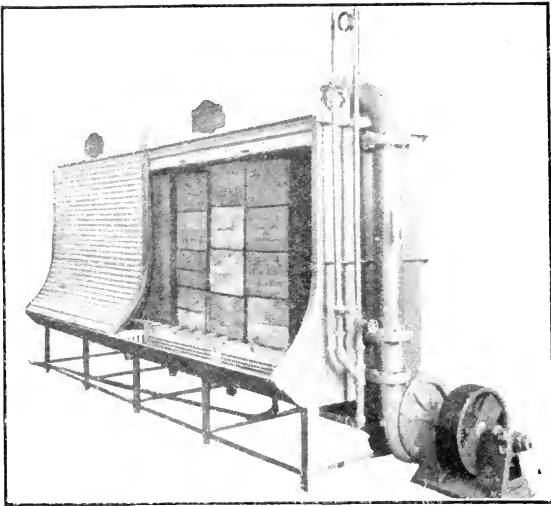

FIG. 86.—A pasteurizer for milk in bottles.

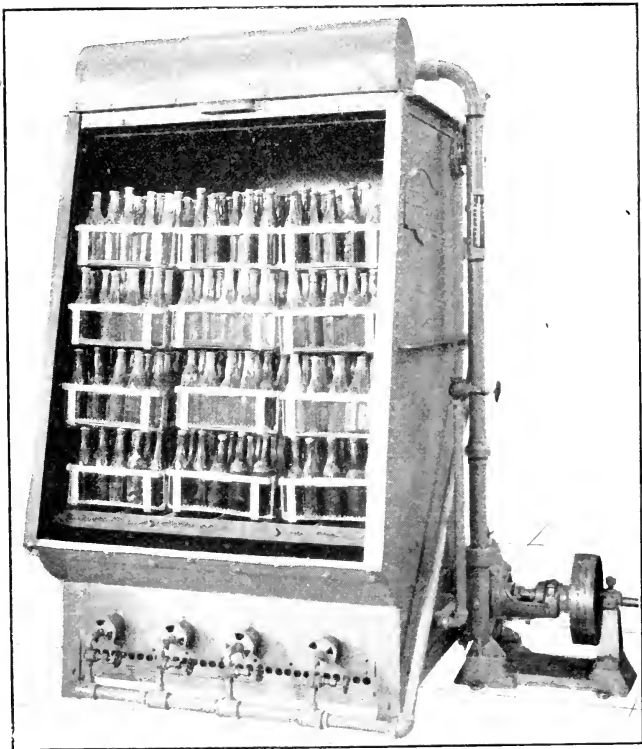

FIG. 87.—A pasteurizer for grape juice, cider, etc., in bottles.  
(130)



type the temperature is raised to as high as  $85^{\circ}$  for a few seconds only, "flash process" (Fig. 93), and then the

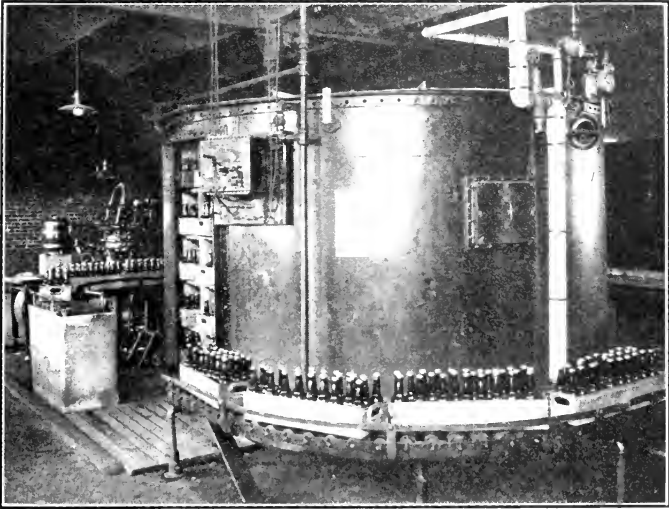

FIG. 88.—A pasteurizer for beer in bottles.

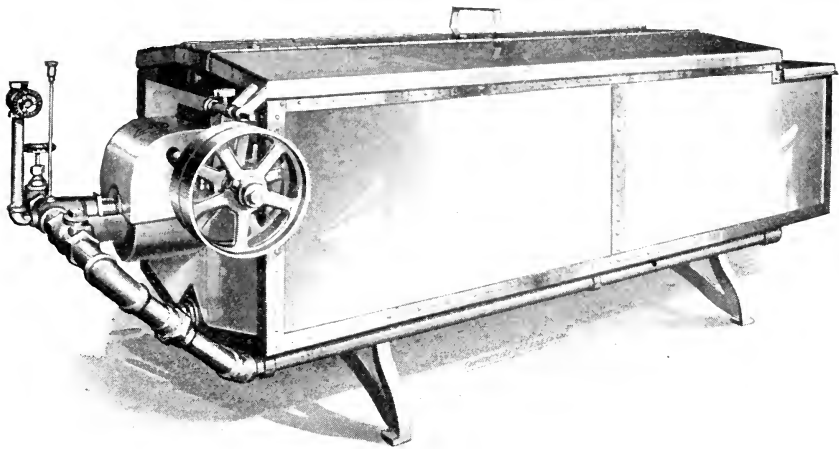

FIG. 89.—A continuous milk pasteurizer.

material is rapidly cooled. It is certain that all pathogenic microorganisms, except the very few spore formers in that

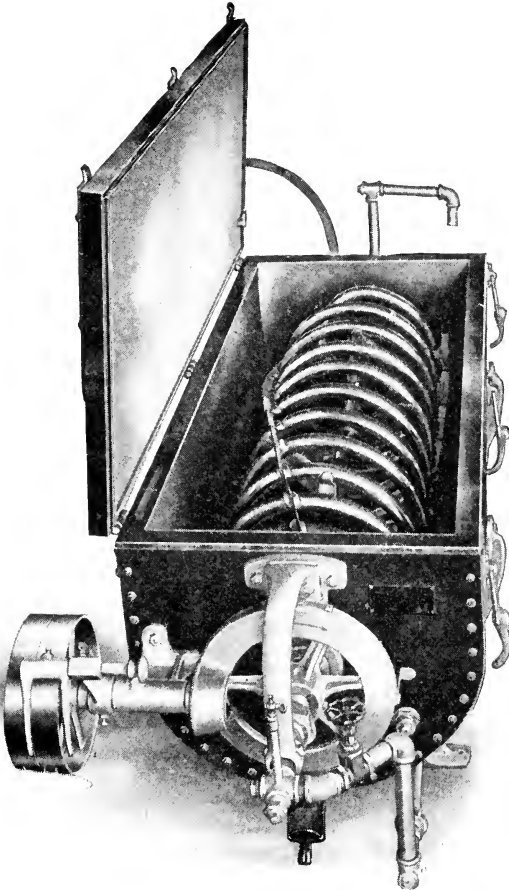

FIG. 90.—A pasteurizer for cream to be used in making ice-cream.

stage, are killed by proper pasteurization. The process is largely employed in the fermentation and dairy industries.

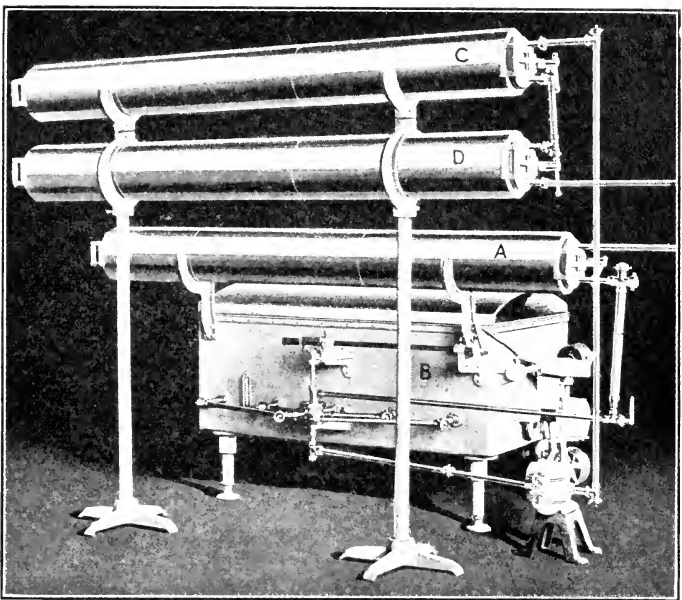

FIG. 91.—A continuous milk pasteurizer with holder. Capacity, 1500 pounds per hour. A, pasteurizer—the milk flows in tubes inside of a jacket of water heated to the proper temperature; B, holder; C, water cooler; D, brine cooler.

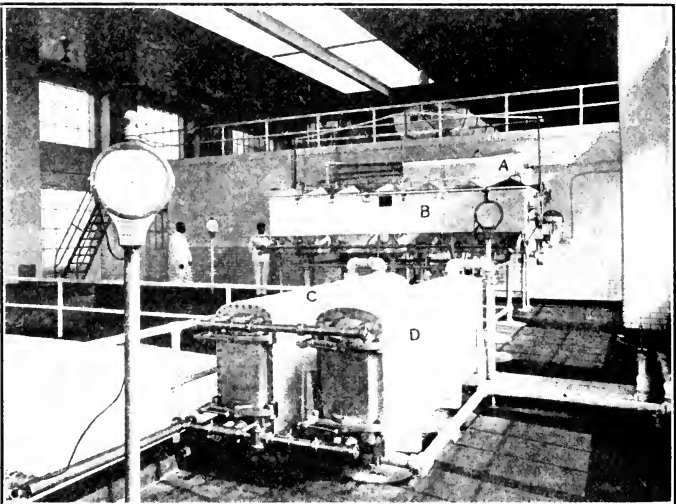

FIG. 92.—A continuous pasteurizing plant in operation. Similar to Fig. 91 but larger. Capacity, 12,000 pounds per hour. A, pasteurizer; B, seven compartment holder; C, D, coolers.

3. **Cold.**—That *cold* is an excellent *antiseptic* is illustrated by the general use of refrigerators and “cold storage.” Numerous experiments have shown that although many pathogenic organisms of a given kind are killed by temperatures below freezing, not all of the same kind are, and many kinds are only slightly affected. Hence cold cannot be considered a practical means for *disinfection*.

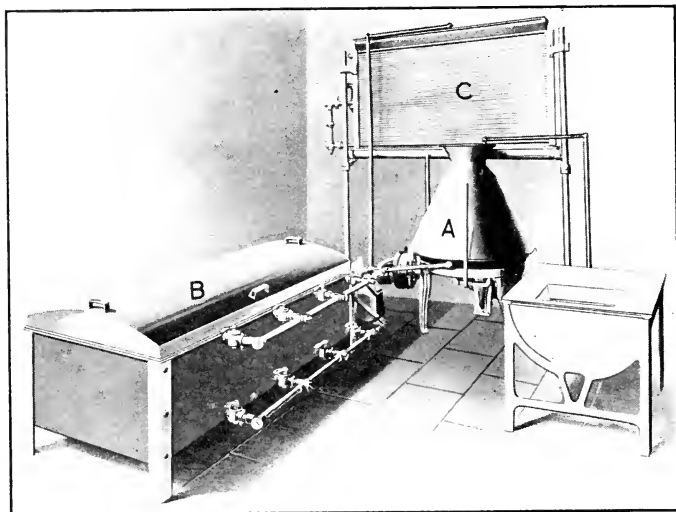

FIG. 93.—A “flash process” pasteurizing outfit, with holder. A, flash pasteurizer; B, holder; C, cooler.

4. **Light.**—It has been stated (page 54) that light is destructive to bacteria, and the advisability of having well-lighted habitations for men and animals has been mentioned. The practice of “sunning” bedclothing, hangings and other large articles which can scarcely be disinfected in a more convenient way is the usual method of employing this agent. Drying and the action of the oxygen of the air assist the process to some extent. Undoubtedly large numbers of pathogenic organisms are destroyed under natural conditions by the combined effects of drying, direct sunlight and

oxidation, but it should not be forgotten that a very slight protection will prevent the action of light (Figs. 94 and 95).

5. **Osmotic Pressure.**—Increase in the concentration of substances in solution is in practical use as an *antiseptic* procedure. Various kinds of “sugar preserves,” salt meats and condensed milk are illustrations. It must be remembered that a similar increase in concentration occurs when



FIG. 94.—Effect of light on bacteria.  $\times \frac{7}{10}$ . The plate was inoculated in the usual way. A letter *H* of black paper was pasted on the bottom. The plate was then exposed for four hours to the sun in January outside the window and then incubated. The black paper protected the bacteria. Outside of it they were killed except where they happened to be in large masses. Hence the letter shows distinctly. (Student preparation.)

many substances are dried, and is probably as valuable in the preservative action as the loss of water. That the process cannot be depended on to *kill* even pathogenic organisms is shown by finding living tubercle bacilli in condensed milk. The placing of bacteria in water or in salt solution in order to have them die and disintegrate (greatly aided by vigorous shaking in a shaking machine) (“autolysis,”

page 112) is a laboratory procedure to obtain cell constituents. It is not a practical method of disinfection, however.

6. **Electricity.**—Electricity, though not in itself injurious to bacteria, is used as an indirect means for destroying bacteria in a practical way. This is done by electrical production of some substance which is destructive to bacteria, as in ozone water purification (Leningrad, Florence and else-



FIG. 95.—Effect of light on bacteria.  $\times \frac{7}{10}$ . This plate was treated exactly as the plate in Fig. 94, except that the letter is *L* and that it was exposed inside the window and wire screen. The window was plate glass. It is evident that few of the bacteria were killed, since the letter *L* is barely outlined. The exposure was at the same time as the plate in Fig. 94. (Student preparation.)

where), or the use of ultraviolet rays for the same purpose (Marseilles, Paris) and for treatment of certain disease conditions. Electricity might be used as a source of heat for disinfecting purposes should its cheapness justify it. It has also been used in the preservation of meats to hasten the *penetration of the salt* and thus reduce the time of pickling. Electrolyzed sea water has been tried as a means of flushing

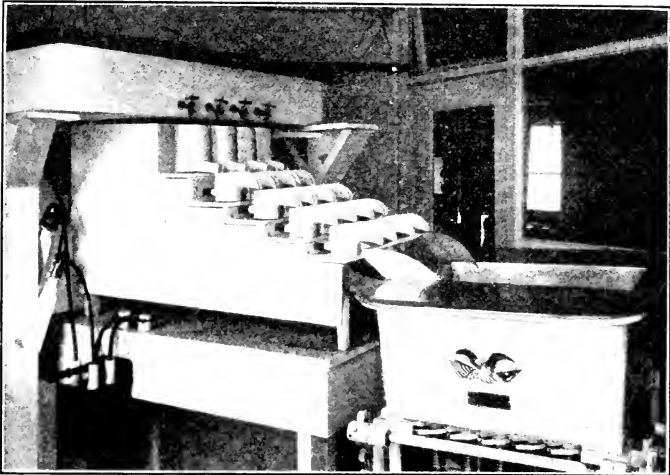

FIG. 96.—An electric milk purifier (pasteurizer). The milk flowing from cup to cup completes the circuit when the current is on. The effect is certainly a heat effect. Sparking occurs at the lips of the cups.

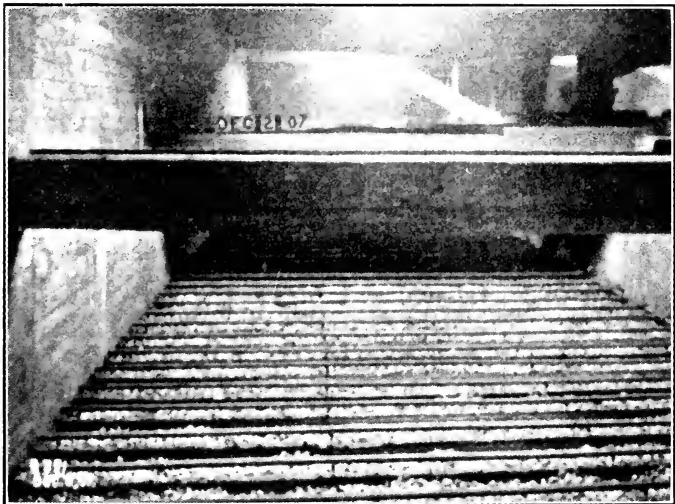

FIG. 97.—One of the ten filter beds of the Columbus water-filtration plant with the filtering material removed. Sand is the filtering material. All of the beds together have a capacity of 30,000,000 gallons daily.

and disinfecting streets, but it is very doubtful if the added expense is justified by any increased benefit. A number of electric devices have been put forth for various sterilizing and disinfecting purposes and doubtless will continue to be, but every one should be carefully tested before money is invested in it.<sup>1</sup>

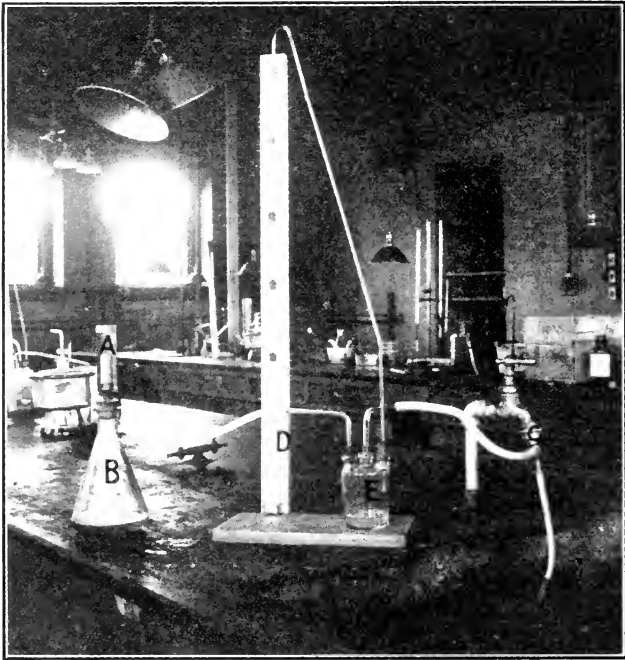

FIG. 98.—Suction filtration. *A*, Berkefeld filter in glass cylinder containing the liquid to be filtered; *B*, sterile flask to receive the filtrate as it is drawn through; *C*, water pump; *D*, manometer, convenient for detecting leaks as well as showing pressure; *E*, bottle for reflux water.

**7. Filtration.**—Filtration is a process for rendering fluids sterile by passing them through some material which will

<sup>1</sup> The author has tested an “electric milk purifier” (Fig. 96) which was as efficient as a first-class pasteurizer and left the milk in excellent condition both chemically and as far as “cream line” was concerned. The cost of operation as compared with steam will depend on the price of electricity.



hold back the bacteria. It is used on a large scale in the purification of water for sanitary or manufacturing reasons (Fig. 97). Air is also rendered "germ-free" in some surgical operating rooms, "serum laboratories" and breweries by filtration. In the laboratory it is a very common method of sterilizing liquids which would be injured by any other

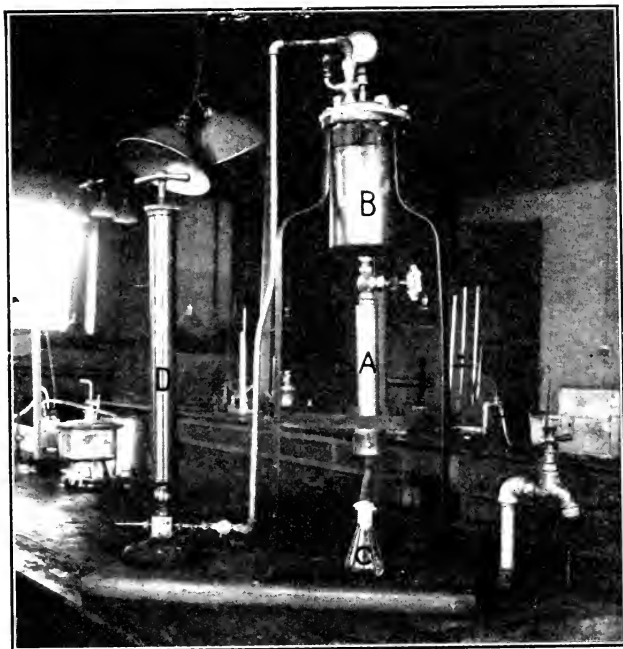

FIG. 99.—Pressure filtration. *A*, cylinder which contains the filter candle; *B*, cylinder for the liquid to be filtered; *C*, sterile flask to receive the filtrate; *D*, air pump to furnish pressure.

process. The apparatus consists of a porous cylinder with proper devices for causing the liquid to pass through either by suction (Fig. 98), where the pressure will be only one atmosphere (approximately 15 pounds per square inch), or by the use of compressed air at any desired pressure (Fig. 99). The two main types of porous cylinders ("filter

candles," "bougies") are the Pasteur-Chamberland (Fig. 100) and the Berkefeld. The former are made of unglazed porcelain of different degrees of fineness, the latter of diatomaceous earth (Fig. 101). The Mandler filter of this same material is now manufactured in the United States and is equal if not superior to the Berkefeld. The designs of complete apparatus are numerous.

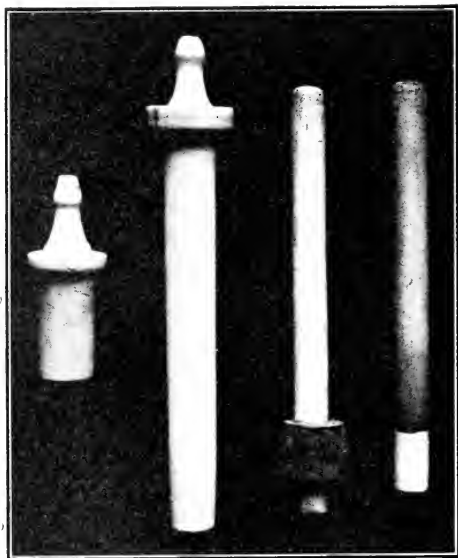

FIG. 100.—Pasteur-Chamberland filter candles about one-half natural size.

8. **Burying.**—This is a time-honored method of disposing of infected material of all kinds and at first thought might not be considered a means of *disinfection*. As a matter of fact, under favorable conditions it is an excellent method. The infected material is removed. Pathogenic organisms tend to die out in the soil owing to an unfavorable environment as to temperature and food supply, competition with natural soil organisms for what food there is and the injurious effects of the products of these organisms. Care must

be taken that the burial is done in such a way that the *surface* soil is not contaminated either directly or by material brought up from below by digging or burrowing animals, insects, worms or movement of ground water to the surface. Also that the underground water supply which is

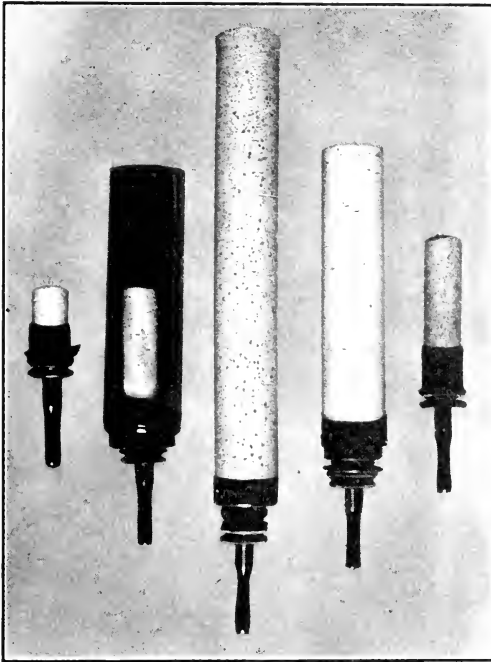

FIG. 101.—Berkefeld filter candles about one-half natural size.

drawn upon for use by men or animals is not contaminated. Frequently infected material, carcasses of animals, etc., are treated in some way so as to aid the natural process of destruction of the organisms present, especially by the use of certain chemical agents, as quicklime (see page 144).

## CHAPTER XIV.

### DISINFECTION AND STERILIZATION (CONTINUED).

#### CHEMICAL AGENTS.

A VERY large number of chemical substances might be used for destroying bacteria or preventing their growth either through direct injurious action or by the effect of concentration. Those which are practically useful are relatively few, though this is one of the commonest methods of disinfecting, and the word "disinfectant" is frequently wrongly restricted to chemical agents.

Chemical agents act on bacteria in a variety of ways. Most commonly there is direct union of the chemical with the protoplasm of the cell and consequent injury. Sometimes the chemical is first precipitated on the surface of the cell without penetrating at once. If removed soon enough, the organism is not destroyed. This is true of bichloride of mercury and formaldehyde. If bacteria treated with these agents in injurious strength be washed with ammonia or ammonium sulphate, even after a time which would otherwise result in their failure to grow, they will develop. Some chemicals change the reaction of the material in a direction unfavorable to growth, and if the change is enough, may even kill the bacteria. Some agents remove a chemical substance necessary to the growth of the organism and hence inhibit it. Such actions are mainly preventive (antiseptic) and become disinfectant only after a long time.

#### ELEMENTS.

**Oxygen.**—Oxygen as it occurs in the air is probably not injurious to living bacteria but aids them with the excep-

tion of the anaërobes. In the nascent state especially, as liberated from ozone ( $O_3$ ), hydrogen peroxide ( $H_2O_2$ ) and hypochlorites ( $Ca(ClO)_2$ ), it is strongly bactericidal.

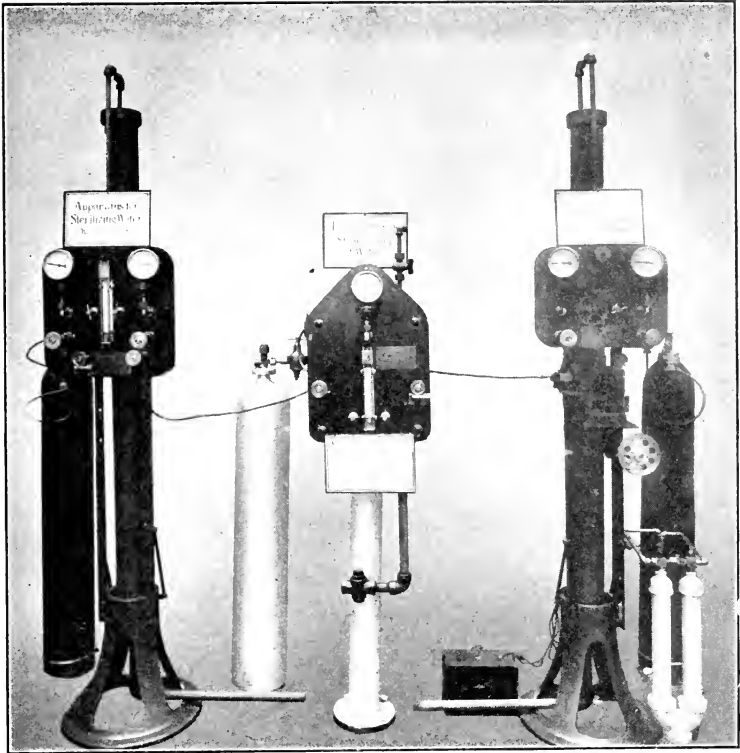

FIG. 102.—Apparatus for sterilizing water with liquid chlorine.

**Chlorine.**—Chlorine is actively disinfectant and is coming into use for sterilizing water on a large scale in municipal plants (Fig. 102).

*Iodine* finds extended use in aseptic surgical operations and antiseptic dressings. Bromine, mercury, silver, gold, nickel, zinc and copper are markedly germicidal in the elemental state, but are not practical.

## COMPOUNDS.

**Calcium Oxide.**—Calcium oxide ( $\text{CaO}$ ), *quicklime*, is an excellent disinfectant for stables, yards, outhouses, etc. where it is used in the freshly slaked conditions as “white wash”; also to disinfect carcasses to be buried. It is very efficient against the typhoid bacillus in water, where it is much used to assist in the softening.

**Chloride of Lime.**—Chloride of lime, *bleaching powder*, which consists of calcium hypochlorite, the active agent, and chloride and some unchanged quicklime is one of the most useful disinfectants. It is employed to sterilize water for drinking purposes on a large scale and to disinfect sewage plant effluents. A 5 per cent solution is the proper strength for ordinary disinfection. Only a supply which is fresh or has been kept in air-tight containers should be used, as it rapidly loses strength on exposure to the air. The active agent is nascent oxygen liberated from the decomposition of the hypochlorite.

**Sodium Hypochlorite.**—Sodium hypochlorite prepared by the electrolysis of common salt has been used to some extent.

**Bichloride of Mercury.**—Bichloride of mercury, *mercuric chloride, corrosive sublimate* ( $\text{HgCl}_2$ ), is the strongest of all disinfectants under proper conditions. It is also extremely poisonous to men and animals and great care is necessary in its use. It is precipitated by albuminous substances and attacks metallic objects, hence should not be used in the presence of these classes of substances.

It is used in a strength of one part  $\text{HgCl}_2$  to 1000 of water for general disinfection. Ammonium chloride or sodium chloride, common salt, in quantities equal to the bichloride, or citric acid in one-half of the amount, should be added in making large quantities of solution or for use with albuminous fluids to prevent precipitation of the mercury (Fig. 103).

None of the other metallic salts are of value as practical disinfectants aside from their use in surgical practice. In this latter class come boric acid, silver nitrate and potassium permanganate. The strong mineral acids and alkalis are, of course, destructive to bacteria, but their corrosive effect

excludes them from practical use, except that "lye washes" are of value in cleaning floors and rough woodwork, but even here better *disinfection* can be done more easily and safely.

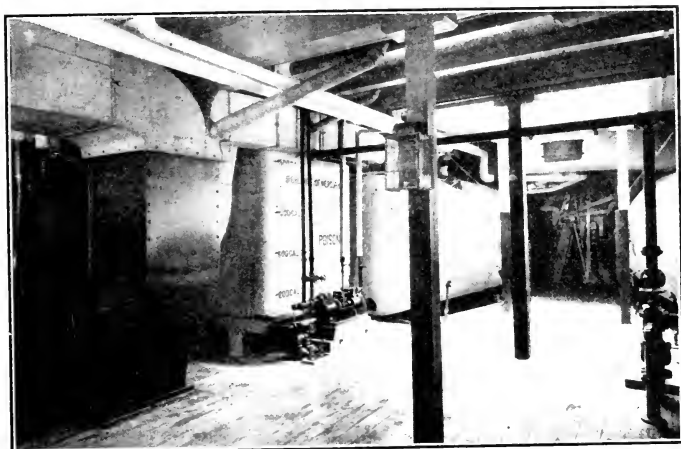

FIG. 103.—Tanks for bichloride of mercury, government quarantine disinfecting plant.

### ORGANIC COMPOUNDS.

**Carbolic Acid or Phenol.**—Carbolic acid or phenol ( $C_6H_5OH$ ) is one of the commonest agents in this class. It is used mostly in 5 per cent solution as a disinfectant and in 0.5 per cent solution as an antiseptic. For use in large quantities the crude is much cheaper and, according to some experimenters, even more active than the pure acid, owing to the cresols it contains. The crude acid is commonly mixed with an equal volume of commercial sulphuric acid and the mixture is added to enough water to make a 5 per cent dilution, which is stronger than either of the ingredients alone in 5 per cent solution.

**Cresols.**—The cresols ( $C_6H_4CH_3OH$ , ortho, meta and para), coal-tar derivatives, as phenol, are apparently more powerful disinfectants. A great number of preparations

containing them have been put on the market. *Creolin* is one which is very much used in veterinary practice and forms a milky fluid with water, while *lysol* forms a clear frothy liquid owing to the presence of soap. Both of these appear to be more active than carbolic acid and are less poisonous and more agreeable to use. They are used in 2 to 5 per cent solution.

**Alcohol.**—Ordinary (ethyl) alcohol ( $C_2H_5OH$ ) is largely used as a *preservative*, also as a disinfectant for the body surface, hands and arms. Experiments show that alcohol of 70 per cent strength is most strongly bactericidal and that absolute alcohol is very slightly so.

**Soap.**—Experimenters have obtained many conflicting results with soaps when tested on different organisms, as is to be expected from the great variations in this article. Miss Vera McCoy, in the author's laboratory, carried out experiments with nine commercial soaps—Ivory, Naphtha, Packer's Tar, Grandpa's Tar, Balsam Peru, A. D. S. Carbolic, German Green, Dutch Cleanser, Sapolio—and obtained abundant growth from spores of *Bacillus anthracis*, from *Escherichia coli* and from *Staphylococcus aureus* in all cases even when the organisms had been exposed twenty-four hours in 5 per cent solutions. From these results and from the wide variations reported in the literature it is clear that *soap solutions alone cannot be depended on* as disinfectants. Medicated soaps do not appear to offer any advantages in this respect. The amount of the disinfectant which goes into solution when the soap is dissolved is too small to have any effect.

**Formaldehyde.**—Formaldehyde ( $HCHO$ ) is perhaps the most largely used chemical disinfectant at the present time. The substance is a gas but occurs most commonly in commerce as a watery solution containing approximately 40 per cent of the gas. This solution is variously known as formalin, formol and formaldehyde solution. The first two names are patented and the substance under these names usually costs more. It is used in the gaseous form for disinfecting closed spaces of all kinds to the exclusion of most other means today. A great many types of formalin generators have been devised. The gas has little power of



penetration and all material to be reached should be exposed as much as possible. The dry gas is almost ineffective, so that the objects must be moistened or vapor generated along with the gas. A common method in use is to avoid expensive generators by pouring the formaldehyde solution on permanganate of potash crystals placed in a vessel removed from inflammable objects on account of the heat developed, which occasionally sets the gas on fire. The formalin is used in amounts varying from 20 to 32 ounces to  $8\frac{1}{2}$  to 13 ounces of permanganate to each 1000 cubic feet of space. This method is expensive, since one pint (16 ounces) of formalin is sufficient for each 1000 cubic feet, and since the permanganate is an added expense. Dr. Dixon, Commissioner of Health of Pennsylvania, recommends the following mixture to replace the permanganate, claiming that it works more rapidly and is less expensive and just as efficient:

1. Sodium bichromate, 10 ounces.
2. Saturated solution of formaldehyde, 16 ounces.
3. Common sulphuric acid,  $1\frac{1}{2}$  ounces.

Two and 3 are mixed together and when cool are poured on the bichromate, which is placed in an earthenware jar of a volume about ten times the quantity of fluid used. The quantities given are for each 1000 cubic feet of space.

A very simple method is to cause the formalin, diluted about twice with water to furnish moisture enough, to drop by means of a regulated "separator funnel" on a heated iron plate. The dropping should be so regulated that each drop is vaporized as it falls. The plate must have raised edges, pan-shaped, to prevent the drops rolling off when they first strike the plate. Formaldehyde has no corrosive (except on iron) or bleaching action, and is the most nearly ideal closed space disinfectant today. In disinfecting stations it is made use of in closed sterilizers such as were described under steam disinfection, particularly in connection with vacuum apparatus. It is also used in solution as a preservative and as a disinfectant. The commonest strength is 2 or 3 per cent of formalin or 0.8 to 1.2 per cent of the formaldehyde gas. As an *antiseptic* it is efficient in dilu-

tions as high as 1 to 2000 of the gas. It is very irritant to mucous membranes of most individuals.

**Anilin Dyes.**—Some of the anilin dyes show remarkable selective disinfectant and antiseptic action on certain kinds of bacteria with little effect on others. This has been well shown by Churchman in his work on Gentian Violet. This dye inhibits the growth of *Gram-positive* organisms up to a dilution of one part in 300,000 while on *Gram-negative* organisms it is without effect even in saturated solution. This is nicely shown in the accompanying illustration. This inhibiting effect of anilin dyes is taken advantage of in several methods of isolating bacteria (Chapter XVIII).



FIG. 104.—The lower half of the plate is plain agar medium, the upper half the same medium plus gentian violet to make 1 part in 300,000. The Gram-positive organism is on the right and the Gram-negative on the left. Streak inoculations were made across both media.

In addition to the above-discussed disinfectants a large number of substances, particularly organic, are used in medicine, surgery, dentistry, etc., as more or less strong antiseptics, and the list is a constantly lengthening one.

In the laboratory chloroform,  $H_2O_2$ , ether and other volatile or easily decomposable substances have been used to sterilize liquids which could not be treated by heat or by filtration. The agent is removed either by slow evaporation or by exhausting the fluid with an air pump. The method is not very satisfactory, nor is absolute sterilization easily accomplished. It is much better to secure such liquids aseptically where possible.

## CHAPTER XV.

### DISINFECTION AND STERILIZATION (CONTINUED).

#### CHOICE OF AGENT.

THE choice of the above-described agents depends on the conditions. Evidently a barn is not to be disinfected in the same way that a test-tube in the laboratory is sterilized. Among the factors to be considered in making a choice is the thing to be disinfected or sterilized, its size and nature, that is, whether it will be injured by the process proposed, cost of the agent, especially when a large amount of material is to be treated. Among the conditions which affect the action of all agents the following should be borne in mind particularly when testing the disinfecting power of chemical agents:

1. *The kind of bacterium* to be destroyed, since some are more readily killed by a given disinfectant than others, even though no spores are present.

2. *The age of the culture.* Young bacteria less than twenty-four hours old are usually more readily killed than older ones, since the cell wall is more delicate and more easily penetrated, though old growths may be weakened by the accumulation of their products and be more easily destroyed.

3. *Presence of spores,* since they are much more resistant than the growing cells.

4. Whether the organism is a "good" or "bad" growth, *i. e.*, whether it has grown in a favorable environment and hence is vigorous, or under unfavorable conditions and hence is weak.

5. *The number of bacteria present,* since with chemical agents the action is one of relative masses.

6. *Nature of the substance in which the bacteria are.* Metallic salts, especially bichloride of mercury, are precipi-

tated by albuminous substances and if employed at all must be used in several times the ordinary strength. Solids require relatively more of a given solution than liquids.

7. *State of the disinfectant*, whether solid, liquid or gas, and whether it is ionized or not. Solutions penetrate best and are therefore more quickly active and more efficient.

8. *The solvent*. Water is the best solvent to use. Strong alcohol (90 per cent +) diminishes the effect of carbolic acid, formaldehyde and bichloride of mercury. Oil has a similar effect. The action is probably to prevent the penetration of the disinfectant.

9. *Strength of solution*. The stronger the solution the more rapid and more certain the action, for the same reason as mentioned under 5. In fact, every disinfectant has a strength below the lethal at which it stimulates bacterial growth.

10. *Addition of salts*. Common salt favors the action of bichloride of mercury and also of carbolic acid. Other salts may hinder by precipitating the disinfectant.

11. *Temperature*. Chemical disinfectants, as a rule, follow the general law that chemical action increases with the temperature up to the point where the heat of itself is sufficient to kill.

12. *Time of action*. It is scarcely necessary to point out that a certain length of time is necessary for any disinfectant to act. One may touch a red-hot stove and not be burned. All the above-mentioned conditions are influenced by the time of action.

#### STANDARDIZATION OF DISINFECTANTS— “PHENOL COEFFICIENT.”

Many attempts have been made to devise standard methods for testing the relative strengths of disinfectants. The one most widely used in the United States is the so-called “Hygienic Laboratory” method of determining the “phenol coefficient” of the given substance and is a modification of the method originally proposed by Rideal and Walker in England. In this method as proposed by Anderson

and McClintic, formerly of the above laboratory, the strength of the dilution of the disinfectant to be tested which kills a culture of *Eberthella typhi* in two and a half minutes is divided by the strength of the dilution of carbolic acid which does the same; and the dilution which kills in fifteen minutes is likewise divided by the corresponding dilution of carbolic acid. The two ratios thus obtained are averaged and the result is the "phenol coefficient." For example,

Phenol	1: 80	killed in 2½ minutes
Disinfectant "A"	1: 375	" " " "
Phenol	1: 110	" " 15 "
Disinfectant "A"	1: 650	" " " "
	$375 \div 80 = 4.69$	
	$650 \div 110 = 5.91$	
	—————	
	2) 10.60	
	—————	

Average = 5.30 = "phenol coefficient."

Standard conditions of temperature, age of culture, medium reaction, etc., and of making the dilutions and transfers are insisted on. Details may be found in the *Journal of Infectious Diseases*, 1911, 8, page 1.

This is probably as good a method as any for arriving at the relative strengths of disinfectants, and in the hands of any given worker concordant results in comparative tests can usually be attained. Experience has shown that the results obtained by different workers with the same disinfectant may be decidedly at variance. This is to be expected from a knowledge of the factors affecting the action of disinfectants above stated, and from the known specific action of certain disinfectants on certain organisms (compare anilin dyes, page 148).

It seems that the only sure way to test the action of such a substance is to try it out in the way it is to be used. It is scarcely wise to adopt the "phenol coefficient" method as a legal standard method, as some states have done.

## PRACTICAL STERILIZATION AND DISINFECTION.

The methods for sterilizing in the laboratory have been discussed and will be referred to again in the next chapter.

In practical disinfection it is a good plan always to *proceed as though spores were present* even if the organism is known. Hence use an *abundance of the agent* and *apply it as long as practicable*. Also it is best to secure the *chemical substances used as such* and *not depend on patented mixtures purporting to contain them*. As a rule the latter are *more expensive in proportion to the results secured*.

*Surgical instruments* may be sterilized by boiling in water for fifteen minutes, provided they are clean, as they should be. If dried blood, pus, mucus, etc., are adherent, which should never be the case, they should be boiled one-half hour. The addition of sodium carbonate (0.5 to 1 per cent) prevents rusting. Surgeons' sterilizers are to be had at reasonable prices and are very convenient. Whether the instruments are boiled or subjected to streaming steam depends on whether the supporting tray is covered with water or not. The author finds it a good plan to keep the needles of hypodermic syringes in a 5 per cent solution of phenol in glycerin.

*Rooms, offices* and all spaces which may be readily made practically gas-tight are best disinfected by means of formaldehyde by any of the methods above described (Figs. 105 and 106).

*Stables and Barnyards* (Mohler): "A preliminary cleaning up of all litter is advisable together with the scraping of the floor, mangers and walls of the stable with hoes and the removal of all dust and filth. All this material should be burned since it probably contains the infective agent. Heat may be applied to the surfaces, including barnyard, by means of a 'cyclone oil burner.' When such burning is impracticable the walls may be disinfected with one of the following:

1. Whitewash 1 gallon + chloride of lime 6 ounces.
2. Whitewash 1 gallon + crude carbolic acid 7 ounces.
3. Whitewash 1 gallon + formalin 4 ounces.

The same may be applied with brushes or, more rapidly, sprayed on with a pump; the surface soil of the yard and surroundings should be removed to a depth of 5 or 6 inches, placed in a heap and thoroughly mixed with quicklime.

The fresh surface of soil thus exposed may be sprinkled with a solution of a chemical disinfectant as above described.

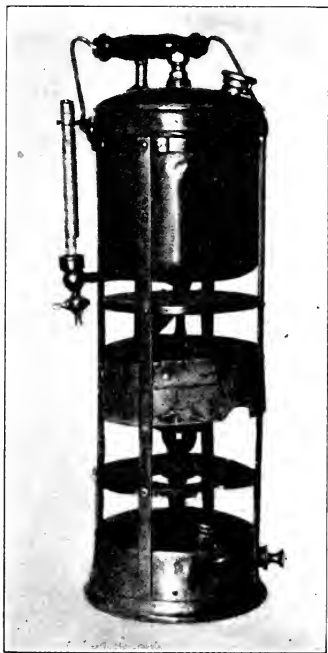

FIG. 105.—Formaldehyde generator used in city work for room disinfection.

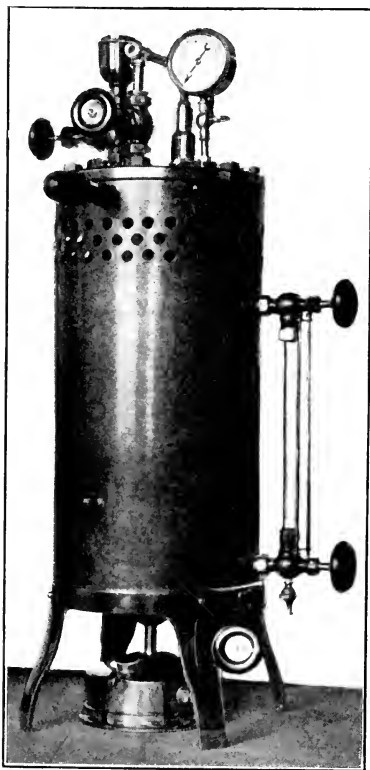

FIG. 106.—Government formaldehyde generator.

“Portions of walls and ceiling not readily accessible may be disinfected by chlorine gas liberated from chloride of lime by crude carbolic acid. This is accomplished by making a cone of 5 or 6 pounds of chloride of lime, in the top of which a deep crater is made for the placement of from

1 to 2 pints of crude carbolic acid. The edge of the crater is thereupon pushed into the fluid, when a lively reaction follows. Owing to the heat generated, it is advisable to place the chloride of lime in an iron crucible (pot) and to have nothing inflammable within a radius of 2 feet. The number and location of these cones of chloride of lime depend on the size and structure of the building to be disinfected. As a rule it may be stated that chlorine gas liberated from the above sized cone will be sufficient for disinfecting 5200 cubic feet of air space."

*Liquid manure, leachings, etc.*, where collected are thoroughly disinfected by chloride of lime applied in the proportion of 2 parts to 1000 of fluid.

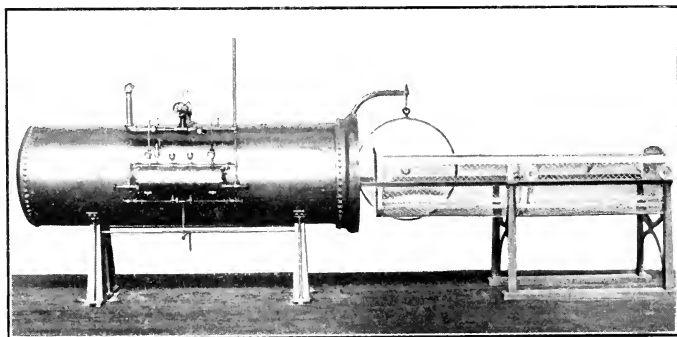

FIG. 107.—Chamber used in government work for formaldehyde disinfection. The small cylinder at the side is the generator.

*Vehicles* may be thoroughly washed with 2 per cent formalin solution, or if closed space is available, subjected to formaldehyde gas disinfection, after cushions, hangings, etc., have been removed and washed with the disinfectant.

*Harness, brushes, combs* should be washed with a solution of formalin, carbolic acid or creolin as given under these topics.

*Washable articles* should be boiled, dropped into disinfectant solutions as soon as soiled and then boiled or steamed.

*Unwashable Articles.*—Burn all possible. Use formaldehyde gas method in a closed receptacle (Fig. 107).



*Stock Cars.*—The method described for stables is applicable here.

*Animals, large and small,* may have the coat and surface of the body disinfected by washing with 1 to 1000 bichloride or strong hot soapsuds to which carbolic acid has been added to make a 5 per cent solution; they should then be given a good warm bath.

Frequently time and money are saved by a combination of steam and formaldehyde disinfection. This is a regular practice in municipal and quarantine disinfection (Fig. 108).

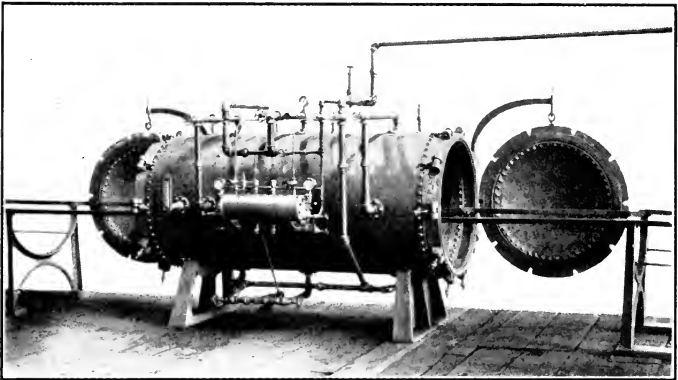

FIG. 108.—Chamber in actual use at government quarantine station for disinfecting baggage and dunnage with steam or formaldehyde or both. The small cylinder at the side is the steam formaldehyde generator.

Persons engaged in disinfection work should wear rubber boots, coats and caps which should be washed in a disinfectant solution and the change to ordinary clothing made in a special room so that no infective material will be taken away.





PART III.

THE STUDY OF BACTERIA.

---

CHAPTER XVI.

CULTURE MEDIA.

THE study of bacteria may be taken up for the disciplinary and pedagogic value of the study of a science; with the idea of extending the limits of knowledge; or for the purpose of learning their beneficial or injurious actions with the object of taking advantage of the former and combating or preventing the latter.

Since bacteria are classed as plants, their successful study implies their cultivation on a suitable soil. A growth of bacteria is called a "culture" and the "soil" or material on which they are grown is called a "culture medium." In so far as the culture medium is made up in the laboratory it is an "artificial culture medium" as distinguished from a natural medium. A culture consisting of one kind of bacteria only is spoken of as a "pure culture," and accurate knowledge of bacteria depends on obtaining them in "pure culture." After getting a "pure culture" the special characteristics of the organism must be ascertained in order to distinguish it from others. The discussion of the *morphology* of bacteria in Chapters II, III and IV shows that the morphological structures are too few to separate individual kinds. They serve at best to enable groups of similarly appearing forms to be arranged. Hence any further differentiation must be based on a study of the *physiology* of the organism as discussed in the chapters on Physiological Activities of Bacteria.

The thorough study of a bacterium involves, therefore:

1. Its isolation in pure culture.
2. Its study with the microscope to determine morphological features and staining reactions.
3. Growth on culture media for determining its physiological activities as well as morphological characteristics of the growths themselves.
4. Animal inoculations in certain instances.
5. Special serum reactions in some cases.

Since isolation in pure culture requires material for growing the organism, the first subject to be considered is culture media.

A culture medium for a given bacterium should show the following essentials:

1. It must contain all the elements necessary for the growth of the organism except those that may be obtained from the surrounding atmosphere.
2. These elements must be in a form available to the organism.
3. The medium must not be too dry, in order to furnish sufficient moisture for growth and to prevent too great a concentration of the different ingredients.
4. The reaction must be adjusted to suit the particular organism dealt with.
5. There must be no injurious substances present in concentration sufficient to inhibit the growth of the organism or to kill it.

Ordinarily, more attention must be paid to the sources of the two elements N and C than to the others, for in general the substances used to furnish these two and the water contain the other elements in sufficient amount. For very exact work on the products of bacteria, *synthetic media* containing definite amounts of chemicals of known composition have been prepared, but for most of the work with bacteria pathogenic to animals such media are not needed.

Culture media may be either *liquid* or *solid*, or for certain purposes may be liquid at higher temperatures and solid at lower, as indicated later. Liquid media are of value for

obtaining bacteria for the study of morphology and cell groupings and for ascertaining many of the physiological activities of the organisms. Solid media are useful for studying some few of the physiological activities and especially for determining characteristic appearances of the isolated growths of bacteria. These isolated growths of bacteria on solid media are technically spoken of as "*colonies*," whether they are microscopic in size or visible to the unaided eye.

It is clear that the kinds of culture media used for the study of bacteria may be unlimited but the undergraduate student will need to use a relatively small number, which will be discussed in this section.

**Meat Broth (Bouillon).**<sup>1</sup>—This itself is used as a medium and as the basis for the preparation of other solid and liquid media.

Finely ground *lean* beef is selected because it contains the necessary food materials. Fat is not desired, since it is a poor food for most bacteria and in the further processes of preparation would be melted and form an undesirable film on the surface of the medium. The meat is placed in a suitable container and mixed with about twice its weight of *cold* water (not distilled) and allowed to soak overnight or longer. The cold water extracts from the meat water-soluble proteins, blood, carbohydrates in the form of dextrose (occasionally some glycogen), nitrogenous extractives and some of the mineral salts. The fluid is strained or pressed free from the meat. This "meat juice" should now be thoroughly boiled, which results in a coagulation of a large part of the proteins and a precipitation of some of the mineral salts, particularly phosphates of calcium and magnesium, both of which must be filtered off and the water loss restored by adding the proper amount of distilled water. The boiling is done at this point because the medium must later be heated to sterilize it and it is best to get rid of the coagulable proteins at once. The proteins thus thrown out

<sup>1</sup> The exact laboratory details for preparing various media are not given in this chapter. It is the object to explain the choice of different materials and the reasons for the various processes to which they are subjected.

deprive the medium of valuable nitrogenous food material which is replaced by adding about 1 per cent by weight of commercial peptone. It is usual also (though not always necessary) to add about 0.5 per cent by weight of common salt which helps to restore the proper concentration of mineral ingredients lost by the boiling. The chlorine is also an essential element. The reaction is now determined and adjusted to the desired end point, "standardized," as it is called. The medium is again *thoroughly* boiled and filtered boiling hot. The adjusting of the reaction and the boiling ordinarily cause a precipitate to form which is largely phosphates of the alkaline earths with some protein. The filtered medium is collected in suitable containers, flasks or tubes, which are plugged with well-fitting non-absorbent cotton plugs and sterilized, best in the autoclave for twenty minutes at 15 pounds pressure, or discontinuously in streaming steam at 100°. If careful attention is paid to *standardization* and to *sufficient boiling* where indicated, the meat broth prepared as above should be clear, only faintly yellowish in color and show no precipitate on cooling.

The conventional method for standardizing an acid medium is as follows: Take 5 cc of the medium, add 45 cc of distilled water and 1 cc of *phenolphthalein* as indicator. Boil the solution and while still hot run in from a burette N/20 NaOH solution until a faint pink color appears. From the number of cc of N/20 NaOH used to "neutralize" the 5 cc of medium it is calculated how many cc of N/1 NaOH are necessary to give the desired end reaction to the volume of medium which is to be standardized. The resulting reaction is expressed as *per cent acid* or *alkaline to phenolphthalein*. If it is necessary to add to each 100 cc of the medium 1 cc of N/1 NaOH to make it neutral to phenolphthalein the reaction is called 1 per cent acid; if to each 100 cc of medium there is added 1 cc of N/1 alkali in addition to the quantity necessary to neutralize the reaction is called 1 per cent alkaline. Objections to this method of standardization will be given later.

### STANDARDIZATION TO A DEFINITE H-ION CONCENTRATION.

It is well established that the controlling factor in the growth of bacteria, in so far as "reaction" is concerned, is not the *titratable substances* present but only the "free acid," *i. e.*, the *number of free H ions*, consequently it is better to determine the concentration of H ions and to *standardize to a definite H-ion concentration*. A discussion of this subject seems therefore appropriate.

It is presumed that the student has had chemistry and is familiar with modern chemical theories. However, the following discussion may not be out of place and may aid in a better understanding of titration and standardization.

By *reaction* is understood the relative concentration of H ions and of OH ions in a solution. Both ions are always present in watery solutions. If H ions are in excess the reaction is called "acid"; if OH ions are in excess the reaction is "alkaline." If the relative concentration of each is the same the reaction is "neutral."

Reaction may be *indicated in per cent of acid present*, or what is more common and much better, the relative amount of H ions present as compared with a solution of known strength. Solutions most commonly used for comparison are *normal solutions*. A *chemical normal solution* is a solution that contains that number of grams per liter of water which corresponds to the *hydrogen equivalent* of the substance. For substances in which there is one replaceable H atom, or its equivalent, the number of grams of the substance dissolved in a liter of water equals the *molecular weight* of the substance. For example, a normal solution of HCl would contain 36.5 (H = 1, Cl = 35.5) grams per liter; of NaCl (Na = 23, and Cl = 35.5) 58.5 grams per liter; of H ions 1 (H = 1) gram per liter. A normal solution of HCl is evidently a normal solution of H ions, since it contains 1 gram H ions per liter. For substances containing two replaceable H atoms or equivalent the *normal solution* will contain the number of grams per liter equal to *one-half the molecular weight*. Normal  $\text{H}_2\text{SO}_4$  is 49 grams per liter ( $\text{H}_2 = 2$ , S = 32,  $\text{O}_4 = 64$ ,  $2 + 32 + 64 = 98$ ,  $\frac{1}{2}$  of 98 = 49).

Normal  $\text{Na}_2\text{SO}_4$  is 71 grams per liter.

For a substance with three replaceable H atoms or equivalent the normal solution will contain the number of grams per liter equal to *one-third the molecular weight*. Normal  $\text{Na}_3\text{PO}_4$  will contain one-third of 164.15 or 54.7 grams per liter.

The strength of a solution is then most commonly expressed in terms of the *normal solution*, as  $\frac{1}{2}$  normal ( $N/2$ ),  $1/100$  normal ( $N/100$ ), etc. *Reaction* may be expressed in terms of a *normal solution of H ions* for acid solutions, or of *OH ions* for alkaline solutions. It is the usual practice to express both in terms of a normal solution of H ions for the sake of uniformity and convenience.

The bacteriologist deals mainly with solutions whose reaction is near the *neutral point*. Pure water is neutral in reaction. The concentration of H ions in pure water is  $1/10,000,000$  of the concentration in a normal solution of H ions, or is  $N/10,000,000$ . The H-ion concentration in a normal NaOH solution is  $1/100,000,000,000,000$  of that of a normal H ion solution. These fractions are unwieldy. It is an improvement to write  $1/10^7$  or  $1/10^{14}$ , etc., though these are still awkward. These fractions mean that in pure water the number of H ions per cubic centimeter is the same as in a cubic centimeter of a normal solution of H ions diluted 10,000,000 times and in normal NaOH solution it is the same as in 1 cubic centimeter of a normal solution of H ions diluted 100,000,000,000,000 times.  $10,000,000 = 10^7 = \log 7$  and  $100,000,000,000,000 = 10^{14} = \log 14$ . Sørensen suggested the symbol *pH* for this *logarithm of the dilution*. This expression has come into quite general use on account of its simplicity. Thus, pure water would have a reaction expressed as *pH7*, normal NaOH, *pH14*, normal HCl, *pH0*. With this method of expression the *larger the figure the less the acidity*, and *vice versa*. Reactions expressed by whole number and a decimal as *pH7.2*, *pH 7.4* would really mean that the number of H ions per liter corresponds to the number per liter of a normal solution diluted the number of times corresponding to that number of which 7.2 is the logarithm or 8.4, etc. 7.2 is the logarithm of 12,195,121.9.

It should be noted that a difference of unity in *pH* means



that the solution with the larger  $pH$  is *ten times as dilute* or  $\frac{1}{10}$  as *strong* as the solution with the lower  $pH$ . A solution with the reaction  $pH7$  is ten times as strong as a solution of the reaction  $pH8$ . The former represents a normal solution diluted *ten million* times, the latter a normal solution diluted *one hundred million* times.

A difference of  $\frac{1}{10}$  in  $pH$  means a difference of 0.9 of a dilution *counting the next whole number as the dilution*. For example,  $pH8$  represents one one-hundred millionth of normal.  $pH7.9$  represents 1 and 0.9 hundred millionths of a normal.  $pH7.8$  represents 2 and 0.8 hundred millionths of a normal, etc., manifestly extremely awkward figures.

This  $pH$  method of expressing reactions in such dilute solutions is evidently very convenient. It is recommended by the Society of American Bacteriologists and is rapidly becoming the standard in the United States.

By *titration* when used with reference to acidity is meant *determining* the relative reaction, *i. e.*, the relative H ion concentration of a solution.

By *standardization* when used with reference to acidity, is meant *adjusting* the reaction to some desired degree of acidity or alkalinity, *i. e.*, to some desired H-ion concentration.

Before discussing methods of titration it will be necessary to review in part the theory of solutions, though the student is presumed to be familiar with this.

Watery solutions may contain any or all of the following classes of substances: *strong electrolytes, weak electrolytes, non-electrolytes*.

Strong electrolytes are so called because their solutions readily conduct the electric current; solutions of weak electrolytes conduct electricity slightly and non-electrolytes not appreciably.

The theory for such conduction is that strong electrolytes in solution dissociate, break up into their component parts, and these component parts carry the current. In not too strong solution this dissociation is practically complete.

*Strong electrolytes* comprise *strong acids, strong bases* and *salts of these*. For example, HCl, H<sub>2</sub>SO<sub>4</sub>, NaOH, KOH, Na<sub>2</sub>SO<sub>4</sub>, KCl, etc. When these substances dissolve in water

they dissociate into two parts called *ions*. One part, the H or metal, is called the *positive ion* or *cation* and the other, the *negative ion* or *anion*. The cation carries a positive charge of electricity and the anion a negative charge. The movement of these ions is the conduction of the current. In a solution of HCl there will be  $H^+$  ions and  $Cl^-$  ions and in dilute solution practically no undissociated HCl. On account of the free H ions in excess the reaction is acid. In a solution of NaOH there will be  $Na^+$  ions and  $OH^-$  ions. The reaction will be alkaline on account of the excess OH ions.

If to a solution of HCl in water a solution of NaOH in water is added the amount of free H ions in relation to the OH ions *will be diminished in proportion to the NaOH added*. If an equal volume of a *normal solution* of NaOH be added to a given volume of normal HCl the mixture will become *neutral* because the relative concentration of H ions and OH ions will be the same.

Weak electrolytes comprise weak acids and bases and salts of these—acetic acid and acetates, carbonic acid and bicarbonates and acid phosphates are examples.

In solutions of weak electrolytes dissociation is relatively slight, so that there is always considerable undissociated weak electrolyte. In a solution of sodium acetate,  $NaC_2H_3O_2$ , in acetic acid solution, there will be H ions,  $C_2H_3O_2$  ions, undissociated acetate and undissociated acetic acid. The addition of NaOH to such solution results largely in *increasing the amount of undissociated sodium acetate* and *diminishing the amount of undissociated acetic acid*, but affecting the relative concentration of free H ions very little unless comparatively large amounts of NaOH are added. If to this acetic acid solution of sodium acetate a strong acid be added the result is to increase the relative amount of *undissociated acetic acid* with little effect on the free H ions, unless large amounts of acid are added.

It thus appears that in solutions of weak electrolytes either acid or alkali may frequently be added *without affecting appreciably the free H-ion concentration, i. e., the reaction*, and that the change in H-ion concentration is *not necessarily proportional to the acid or alkali added*.

In solutions of non-electrolytes there is no dissociation

of the substance. Many of these non-electrolytes have another property which is of great importance in connection with reaction. This is the property which they possess of *forming addition compounds with acid or alkali*. From this it follows that into solutions containing them *acid or alkali may be added without affecting the relative H-ion concentration, i. e., the reaction*.

Substances like weak electrolytes or certain non-electrolytes to whose solutions acid or alkali may be added *without affecting the reaction, i. e., the free H ions*, are called "buffer" substances or "buffers."

The foregoing discussion should make it clear why the method of titration by using phenolphthalein is not necessarily accurate, in fact is not apt to be. The method (page 160) is to add to a definite volume of the solution to be titrated alkali (usually) until a faint pink color is obtained, then to calculate from the amount of alkali used the quantity of alkali to bring the entire bulk of medium to the same end point. *This would be accurate*. The error lies in *assuming that if a less amount of alkali is added the reaction will be proportionately less alkaline or more acid*. From the nature of buffers it should be evident that this is not true. Since reaction is dependent on free H ions, and since in the presence of buffers considerable acid or alkali may be added *without affecting the reaction*, calculations based on the assumption of change in reaction in proportion to the acid or alkali added are very apt to be wrong.

The following series of titrations in a buffered medium illustrates this point nicely. These were made with a potentiometer by Mr. R. Franklin Jukes, instructor in the author's department:

Cc of N/20 NaOH	pH	Increase in pH
0.0	2.7	0.15
0.5	2.85	0.15
1.0	3.00	0.90
1.5	3.9	2.20
2.0	6.1	0.20
2.5	6.3	0.20
3.0	6.5	0.20
3.5	6.7	0.20
4.0	7.0	0.30

This shows that addition of 0.5 cc portions of N/20 NaOH caused changes in reaction of from as little as 0.15  $pH$  to as much as 2.20  $pH$  and that changes in  $pH$  are *not at all proportional to alkali added*.

For this reason other methods of titrating to show the relative H ion concentration have been introduced and are now very generally used in the United States. These methods are two in number, the *electrolytic method* and the use of *indicators* other than phenolphthalein, which show color changes within narrow and definite ranges of H-ion concentration, of  $pH$ .

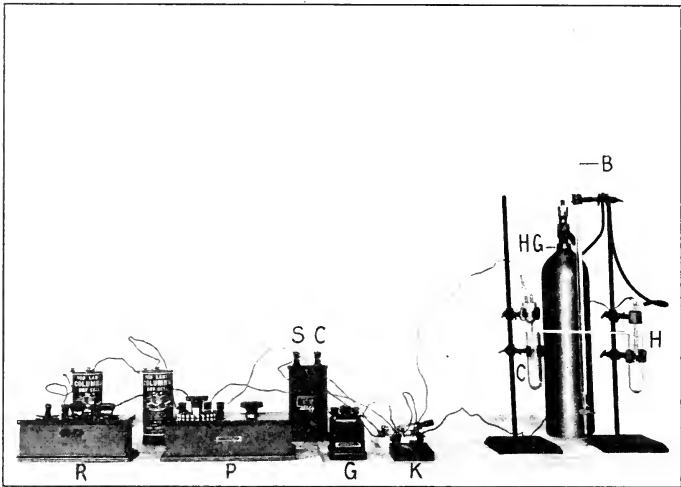

FIG. 109.—Set up of potentiometer outfit for hydrogen-ion determination. Lettering same as Fig. 110.

The *electrolytic method* requires a rather delicate set of apparatus—the potentiometer (Figs. 109 and 110)—which is scarcely adapted for students in introductory courses or for class use and will not be discussed here. Every bacteriological laboratory should be equipped with such an outfit, to be used as a standard of reference and for comparison with other methods in accurate work.

The second method is most commonly called the *colorimetric method*. The phenolphthalein method is also a colorimetric method. The essential difference in the newer method is that indicators are selected which show color changes throughout a definite  $pH$  range and are used *only within this range* and calculations can not be made from the amounts of acid or alkali used to give these color changes and applied outside their range any more than with phenolphthalein. The latter is a very good indicator for its  $pH$  range, which is from  $pH8$  to  $pH9.6$ .

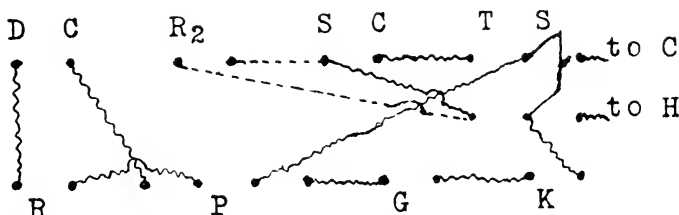

FIG. 110.—Diagram of wiring for set up of potentiometer as illustrated in Fig. 109. In case  $R_2$  (not shown in the photograph) is used the wiring should be according to the dotted lines and not direct from S C to T S.

D C, dry cells; R, rheostat; P, potentiometer; G, galvanometer; K, key; S C, standard cell; T S, two way switch; C, calomel electrode; H, hydrogen electrode;  $R_2$ , extra resistance for protection of the standard cell; H C, cylinder of compressed H (a hydrogen generator may be used); B, burette for adding acid or alkali.

It would be possible to select a series of indicators each of which will show color changes some place between  $pH10$  (normal HCl) and  $pH14$  (normal NaOH).

Clark and Lubs (*Jour. Bact.* II) have suggested the following series with  $pH$  as indicated on page 168.

Many of these are valuable for detecting *changes in reaction* caused by organisms growing in culture media. It has been stated that most bacteria require a medium with an initial reaction in the neighborhood of neutral,  $pH7$ . The table shows three indicators which cover this range: Bromocresol purple  $pH5.2-6.8$ , Bromthymol blue,  $pH6.0-7.6$  and Phenol red,  $pH6.8-8.4$ .

	Chemical names.	Common Names.	Full acid color.	Full alkaline color.	Sensitive pH range
1.	Thymol sulphophthalein (acid range)	Thymol blue (acid range)	Red	Yellow	1.2-2.8
2.	Tetrabromphenol sulphophthalein	Bromphenol blue	Yellow	Blue	3.0-4.6
3.	Orthocaroxybenzeneazodimethyl anilin	Methyl red	Red	Yellow	4.4-6.0
4.	Dibromoorthocresol sulphophthalein	Bromcresol purple	Yellow	Purple	5.2-6.8
5.	Dibromo thymol	Bromthymol blue	Yellow	Blue	6.0-7.6
6.	Phenol sulphophthalein	Phenol red	Yellow	Red	6.8-8.4
7.	Orthocresol sulphophthalein	Cresol red	Yellow	Red	7.2-8.8
8.	Thymol sulphophthalein (alkaline range)	Thymol blue (alkaline range)	Yellow	Blue	8.0-9.6
9.	Phenolphthalein	Phenolphthalein	Colorless	Red	8.0-9.6
10.	Orthocresolphthalein	Cresolphthalein	Colorless	Red	8.2-9.8

## TITRATION AND STANDARDIZATION.

One method of titration is, in general, to prepare a series of tubes of solutions of known  $pH$  with definite amounts of indicator in them. Then a measured quantity of the medium is taken, the same amount of indicator is added and then alkali (or acid) until the *color matches* that in the standard tube having the desired  $pH$ . This method involves the preparation of a series of *standard solutions* of several different chemicals and the making of accurate buffer mixtures from these.<sup>1</sup> This procedure is perhaps too difficult for the ordinary bacteriological laboratory.

Another method is that of Barnet and Chapman,<sup>2</sup> in which *varying amounts of* indicator are added to a series of acid and a series of alkaline tubes. One of each series can be so selected that *when looking through the two tubes together* a color is seen which corresponds to a definite  $pH$ . A series for bromthymol blue,  $pH6.4-7.6$ , as given by Medalia,<sup>3</sup> is shown in pairs in the table below. The acid tubes contain 10 cc of approximately N/100 HCl and the alkaline tubes, 10 cc of approximately N/20 NaOH. The indicator is 0.02 per cent solution in distilled water. The figures are tenths of a cubic centimeter to be added to each 10 cc tube:

Pair No.	Acid.	Alkali.	$pH$ .
1	7	1	6.4
2	6	2	6.6
3	5	3	6.8
4	4	4	7.0
5	3	5	7.2
6	2	6	7.4
7	1	7	7.6

A similar series for phenol red 0.04 per cent solution gives  $pH$  values of 7.0, 7.2, 7.4, 7.6, 7.8, 8.0, 8.2. These two series cover the range for ordinary culture media.

The titration is performed by taking 2 cc of the medium, diluting to 10 cc with distilled water and adding 0.8 cc of indicator. N/20 NaOH is then run in until the proper color

<sup>1</sup> Clark and Lubs, Jour. Bact., 1917, 2, 19-26.

<sup>2</sup> Jour. Am. Med. Assn., 1918, 70, 1062.    <sup>3</sup> Jour. Bact., 1920, 5, 451.

is obtained on comparison with the pair selected to give the desired end point. Calculation shows that twenty-five times this amount will give the quantity of N/1 NaOH per liter of medium.

This method requires no standard solutions and no special apparatus. The alkali and acid should be about the strength indicated, *not stronger*, owing to the effect of strong solutions on the dyes.



FIG. 111.—“Comparator block” for H ion determination. The three tubes in the front row contain the medium. The two behind these on the *outside* contain respectively the color pairs next *above* and next below the end point desired. The other two tubes in the middle row contain distilled water. This is a photograph of a 5-in. block.

The following measurements are better: Block --- 10 cm. cube; 9 holes --- 20 mm. diameter, 90 mm. deep; 3 slots --- 25 mm. long, 12 mm. wide; bottom edge of slots 30 mm. from bottom of block.

Color comparisons are perhaps more certain when made through a comparator block (Fig. 111), though this is not necessary. The tubes containing the solutions should be as nearly the same size, color and clearness as possible.

This method is the simplest yet devised for *pH* deter-



mination, has been tested for the two indicators above mentioned by a Committee of the Society of American Bacteriologists, and is "highly recommended" by them.

If the proper color pairs are furnished the student by the instructor, the titration and standardization will take even less time than the older phenolphthalein titration, though each student should be taught to make up his own pairs.

It must be remembered that media *change in reaction toward the acid* on sterilization, and allowance should be made for this. For exact work a portion of the sterilized media should be restandardized. For ordinary work and the common media the change will be about 0.2  $pH$ , *i. e.*, a medium standardized  $pH7.2$  will change to  $pH7$  after sterilization.

The question is frequently asked why the phenolphthalein method so often gives good results. One reason is that so many of the bacteria usually worked with in the laboratory can grow throughout a fairly wide  $pH$  range. Another is that it *accidentally happens* that standardizing to 1 *per cent acid to phenolphthalein* so frequently brings the  $pH$  within the range of these common organisms.

It is hoped that the above discussion has explained why this method *cannot* give an accurate  $pH$ . Many organisms require a very narrow  $pH$  range. For accurate work, research work and for work which must be duplicated by others the  $pH$  must be as concisely defined as any of the other environmental conditions.

The "colorimetric method" affords the best means yet available for such determination on a laboratory scale. The ultimate standard must be potentiometer determination and every laboratory should possess one as above indicated.

### COLORIMETRIC METHOD OF STANDARDIZATION.

The following outline directions will illustrate how students in the laboratory may use this method.

**Preparation of Standard Colors.**—Select 19 small culture tubes of clear white glass and as nearly the same size as

may be. Into one set of seven place 10 cc of N/20 NaOH solution. Mark these alkali and number from 1-7. Into another set of seven place 10 cc of N/100 HCl solution. Mark these acid and number 1-7. Place in a test tube rack in a double row.

Beginning with No. 1 acid, add to it 0.7 cc of 0.02 per cent solution of bromthymol blue as indicator; No. 2, 0.6 cc; No. 3, 0.5 cc; No. 4, 0.4 cc; No. 5, 0.3 cc; No. 6, 0.2 cc and No. 7, 0.1 cc.

Beginning with No. 1 alkali add to it 0.1 cc of the indicator; No. 2, 0.2 cc; No. 3, 0.3 cc; No. 4, 0.4 cc; No. 5, 0.5 cc; No. 6, 0.6 cc; No. 7, 0.7 cc.

The tubes with corresponding numbers form pairs. Pair No. 1 when looked through shows a color corresponding to  $pH$  6.4, No. 2,  $pH$  6.6, No. 3,  $pH$  6.8, No. 4,  $pH$  7.0, No. 5,  $pH$  7.2, No. 6,  $pH$  7.4 and No. 7,  $pH$  7.6.

#### TITRATION.

Measure out accurately 8 cc of distilled  $H_2O$  into one of the empty tubes; add to it 2 cc of medium and 0.8 cc of indicator. Mix thoroughly. Compare the color with the above pairs to see if the reaction comes within the range of the pairs. *If necessary*, add from a burette N/20 NaOH, one drop at a time, until the color matches that of the pair indicating  $pH$  7.2. From the number of cc of N/20 used, calculate the amount of N/1 NaOH necessary to standardize the volume of medium being made up. Add this to the whole bulk of medium, boil and filter.

Check the filtered medium by the same method.

The other four tubes are used in the comparator block as shown in the illustration (Fig. 111).

**Meat Extract Broth.**—Broth may be prepared from Liebig's or Armour's meat extract by adding 5 g. of either, 10 g. peptone and 5 g. NaCl to 1000 cc of water, boiling to dissolve, then standardizing and filtering as above.

The author after much experience finds *meat juice* preferable to meat extract for broth and other media for pathogenic bacteria, and has abandoned the use of meat extracts for these organisms.

**Glycerin Broth.**—Glycerin broth is made by adding 4 to 6 per cent of glycerin to the broth just previous to the sterilization. The glycerin serves as a source of carbon to certain bacteria which will not grow in the ordinary broth—as *Mycobacterium tuberculosis*.

**Sugar Broths.**—Sugar broths are used for determining the action of bacteria on these carbohydrates, since this is a valuable means of differentiating certain forms, especially those from the intestinal tract. Broth *free from sugar* must first be made. This is done by adding to broth prepared as already described, a culture of some sugar-destroying organism (*Escherichia coli* is ordinarily used), and then allowing the organism to grow in the raw broth at body temperature for twenty-four hours. Any carbohydrate in the broth is destroyed by the *Escherichia coli*. This mixture is then boiled to kill the *Escherichia coli*, restandardized and then 1 per cent by weight of required sugar is added. Dextrose, saccharose and lactose are the most used, though many others are used for special purposes. After the sugar is added the medium must be sterilized by *discontinuous heating* at 100° C for three or four successive days, because long boiling or heating in the autoclave splits up the di- and polysaccharids into simpler sugars and may even convert the simple sugars (dextrose) into acid.

Various other *modified broths* are frequently used for special purposes but need not be discussed here.

**Dunham's Peptone Solution**, frequently used to determine indol production, is a solution of 1 per cent of peptone and 0.5 per cent of salt in tap water. It does not need to be titrated, but should be boiled and filtered into tubes or flasks and sterilized.

**Nitrate Broth.**—Nitrate broth for determining nitrate reduction is 1 per cent of peptone, 0.2 per cent of C. P. potassium nitrate dissolved in distilled water and sterilized.

**Milk.**—Milk is a natural culture medium much used. It should be fresh and thoroughly skimmed, best by a separator or centrifuge to get rid of the *fat*. If the milk is not fresh, it should be titrated as for broth and the reaction adjusted. The milk should be sterilized discontinuously to avoid split-

ting up the lactose as well as action on the casein and calcium phosphate.

*Litmus Milk.*—Litmus milk is milk as above to which litmus has been added as an acid production indicator. The milk should show blue when the litmus is added or be made to by the addition of normal NaOH solution. It should be sterilized discontinuously. Frequently on heating litmus milk the blue color disappears, due to a reduction of the litmus. This blue color will reappear on shaking with air or on standing several days, due to absorption of O and oxidation of the reduced litmus, provided the heating has produced no other change in the milk, as proper heating will not.

**Gelatin Culture Medium.**—Gelatin to the extent of 10 to 15 per cent is frequently added to broth and gives a culture medium of many advantages. It is solid at temperatures up to about 25° and fluid above this temperature, a property which is of great advantage in the isolation of bacteria. (See Chapter XVIII.) Further, gelatin is liquefied (that is, digested, converted into gelatin proteose and gelatin peptone, which are soluble in water and do not gelatinize) by many bacteria and not by others, a valuable diagnostic feature. The gelatin colonies of many bacteria are very characteristic in appearance, as is the growth of many on gelatin in culture tubes.

Gelatin medium may be prepared by adding the proper amount of gelatin (10 to 15 per cent by weight) broken into small pieces (powdered gelatin in the same proportion may be used) to broth, gently warming until the gelatin is dissolved, standardizing as for broth, filtering and sterilizing. It is usually cleared before filtering by stirring into the gelatin solution, cooled to below 60°, the white of an egg for each 1000 cc, and then thoroughly boiling before filtering. The coagulation of the egg albumen entangles the suspended matter so that the gelatin filters perfectly clear, though with a slight yellowish color. The filtering may be done through filter paper if the gelatin is well boiled and filtered boiling hot, but is more conveniently done through absorbent cotton, wet with boiling water.

Or, the gelatin may be added to *meat juice before it is boiled*, then this is heated to about body temperature (not too hot, or the proteins will be coagulated too soon) until the gelatin is dissolved. Then the material is standardized and thoroughly boiled and filtered. The proteins of the meat juice coagulate and thus clear the medium without the addition of egg white. Commercial gelatin is markedly acid from the method of manufacture, hence the medium requires careful titration, even when made from a standardized broth.

Gelatin should be sterilized by discontinuous heating at 100° on three successive days, because long boiling or heating above 100° tends to hydrolyze the gelatin into gelatin proteose and peptone and it will not gelatinize on cooling. It may be heated in the autoclave for ten to fifteen minutes at 10 pounds' pressure and sometimes not be hydrolyzed, but the procedure is uncertain and very resistant spores may not be killed. The medium should be put into the culture tubes in which it is to be used as soon as filtered, and sterilized in these, since, if put into flasks these must be sterilized, and then when transferred to tubes for use, it must be again sterilized unless great care is taken to have the tubes plugged and sterilized first, and in transferring aseptically to these tubes. These repeated heatings are very apt to decompose the gelatin, so it will not "set" on cooling. The prepared and sterilized tubes of gelatin should be kept in an ice-box or cool room, as they will melt in overheated laboratories in summer or winter.

**Agar Medium.**—Agar agar, usually called agar, is a complex carbohydrate substance of unknown composition obtained from certain seaweeds along the coast of Japan, Southeastern Asia and our Pacific Coast States. It occurs in commerce as thin translucent strips or as a powder. It resembles gelatin only in the property its solutions have of gelatinizing when cooled. Gelatin is an albuminoid closely related to the proteins, agar a carbohydrate. Agar is much less soluble in water, 1 or 1.5 per cent of agar giving a jelly as dense as 10 to 15 per cent of gelatin. It dissolves only in water heated to near the boiling-point (98° to 99° C), and only after much

longer heating. This hot solution "jells," "sets" or gelatinizes at about 38° and remains solid until again heated to near boiling. Hence bacteria may be grown on agar at the body temperature (37°) and above and the agar will remain solid, while gelatin media are fluid above about 25°. No pathogenic bacteria and none of the saprophytes liable to be met with in the laboratory are able to "liquefy" agar.

An agar medium is conveniently prepared from broth by adding 1 or 1.5 per cent of the finely divided agar to the broth and boiling until dissolved, standardizing, clearing, filtering and sterilizing. The agar must be thoroughly boiled, usually from ten to fifteen minutes, and the water loss made up by the addition of distilled water before titration. Agar is practically neutral so that there is little difference between the titration of the dissolved agar and the original broth. The agar solution should be kept hot from the beginning to the end, except the cooling down to below 60°, when the egg white for clearing is added. Though filtration through paper is possible as with gelatin, if the agar solution is thoroughly boiled and filtered boiling hot, it is more satisfactory for beginners to use absorbent cotton wet with boiling water and to pour the hot agar through the same filter if not clear the first time. The solidified agar medium is never perfectly clear, but always more or less opalescent. The agar medium may be sterilized in the autoclave for fifteen minutes at 15 pounds' pressure, as the high temperature does not injure the agar.

**Potato Media.**—Potatoes furnish a natural culture medium which is very useful for the study of many bacteria. The simplest, and for most purposes the best, way to use potatoes is in culture tubes as "potato tube cultures" (No. 8, Fig. 116). These are prepared as follows: Large tubes are used. Large healthy potatoes are selected. Each end of the potato is sliced off so as to have parallel surfaces. With a cork-borer of a size to fit the tubes used, cylinders about one and one-half inches long are made. Each cylinder is cut diagonally from base to base. This furnishes two pieces each with a circular base and an oval, sloping surface. The pieces are then washed clean and dropped for a minute

into boiling water to destroy the oxidizing enzyme on the surface which would otherwise cause a darkening of the potato. (The darkening may also be prevented by keeping the freshly cut potatoes covered with clean water until

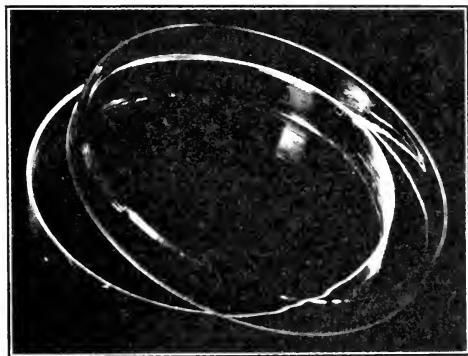

FIG. 112.—Petri dish with the lid partly raised.  $\times \frac{1}{2}$ .

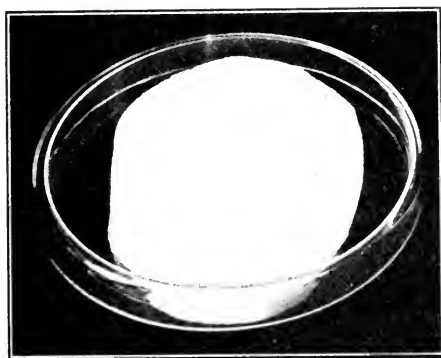

FIG. 113.—A potato plate.  $\times \frac{1}{2}$ .

ready to sterilize.) A bit of cotton one-fourth to one-half inch in depth is put into each of the test-tubes to retain moisture and a piece of potato dropped in, circular base down. The tubes are then plugged with cotton and steril-

ized in the autoclave at 15 pounds' pressure for not less than twenty-five minutes, since potatoes usually harbor very resistant spores, and it is not unusual for a few tubes to spoil even after this thorough heating.

Potatoes are sometimes used in "potato plate cultures." The term "plate culture" is a relic of the time when flat glass plates were used for this and other "plate cultures." Now glass dishes of the general form shown in Fig. 112, called "Petri dishes," or plates, are used for practically all plate culture work. For "potato plates" slices from potatoes are cut as large and as thick as the relative sizes of potato and dish permit (Fig. 113). The slices should be thin enough not to touch the lid and thick enough to be firm.

It is a good plan to wrap each dish separately in paper to retain the lid securely, then sterilize as for potato tubes, and leave plates wrapped until wanted.

It sometimes happens that the natural acidity of potatoes is too great for the growth of many organisms. The acidity is sufficiently corrected by soaking the pieces of potato in a 1 per cent solution of sodium carbonate for an hour before they are put into the tubes or plates.

*Glycerinized potato tubes* are conveniently prepared by covering the potato in the tube with glycerin broth, sterilizing and pouring off the excess broth immediately after sterilizing, taking care that the tubes do not become contaminated, which is not very probable if the work is quickly done while the tubes are still hot.

**Blood Serum Media.**—Blood serum, usually from the larger, domestic animals, on account of convenience in securing it in quantity, is used in the study of the bacteria causing disease in man and animals. Most commonly the serum is collected from the clotted blood after it has well separated (usually about forty-eight hours is required for this). It is then run into tubes which are plugged with cotton and placed in an apparatus for coagulating the serum by heat. A copper water-bath with a tightly closed air compartment or the horizontal autoclave (Fig. 75) is sufficient for this purpose, though special forms of apparatus are



to be had. It is important that the temperature be raised slowly so that the blood gases escape gradually. Three to five hours or longer should be allowed for the temperature to reach the boiling-point. If the tubes are heated too rapidly the serum is filled with bubbles and badly torn since the gases are driven off suddenly. *Löffler's serum* is made by adding one part of dextrose broth to three parts of serum and then coagulating as above. The solidified serum in either case is best sterilized discontinuously, though with care the autoclave at 15 pounds' pressure may be used for a single sterilization. This is very apt to cause a greater darkening of the serum and frequently also a laceration of the solid mass by escaping gases.

Blood serum tubes may be solidified and sterilized at the same time if a good pressure sterilizer is available. Place the tubes in the sterilizer in a sloping position, quickly raise the pressure to 15 pounds and keep it constant (*this is the essential point, to allow no variation in the pressure*) until the tubes are sterile, usually forty-five minutes. Allow the pressure sterilizer to cool gradually before opening.

Blood serum is also used in the liquid state. For this purpose it is best to collect it aseptically; or it may be sterilized discontinuously at a temperature of 55° or 56° on seven to ten consecutive days. Novy has suggested dialyzing the serum to free it from salts and thus prevent its coagulation when heated. Whether the removal of the various "extractives" which diffuse out with the salts deprives the serum of any of its advantageous properties remains to be ascertained.

From the discussion of the physiological activities of bacteria in Chapters IX–XII it is apparent that a very great variety of culture media other than those described is necessary for the study of special types of bacteria, but such media are beyond the scope of the present work.

The ideal culture media are without doubt the *synthetic media*, that is media of definite known chemical composition, so that the various changes due to the growth of bacteria can be accurately determined and thus a means of sharply differentiating closely related organisms be secured. Such

media have been prepared and every bacteriologist believes strongly in their future usefulness when media of wider application shall have been devised. An example of this type of culture media is Ushinsky's synthetic medium, of which the following is one of the modifications:

Distilled water . . . . .	1000 parts
Asparagin . . . . .	4 "
Ammonium lactate . . . . .	6 "
Disodium phosphate . . . . .	2 "
Sodium chloride . . . . .	5 "

A criticism of this medium is that the elements K, Ca, Mg, Fe, Mn, and S, which have been shown to be essential, are not present if chemically pure salts are used in the preparation.

## CHAPTER XVII.

### METHODS OF USING CULTURE MEDIA.

THE way in which culture media shall be used depends on the purpose in view. By far the larger part of bacteriological work is done with cultures in "bacteriological culture tubes." Various laboratories have their own special types, but all are more or less after the "Board of Health" form. They differ from ordinary chemical test-tubes in that they are usually longer, have no "lip" and have much thicker walls to prevent breakage and consequent loss of the culture as well as danger from pathogenic organisms. The author finds two sets of tubes most serviceable for student use—one size 15 cm. long by 19 mm. outside diameter (No. 9, Fig. 116), the other 15 cm. long by 15 mm. (Nos. 1 to 7, Fig. 116). Culture tubes are conveniently used in "wire baskets," circular or square in section, and of a size to correspond with the length and number of tubes used. These baskets are light, do not break, and if made of good galvanized wire netting do not readily rust (Figs. 114 and 115).

Liquid media such as broth, milk, litmus milk, indol and nitrate broths are used in the above-mentioned tubes when small quantities only are to be worked with. The tubes are filled approximately one-third full, then plugged with *non-absorbent* cotton and sterilized. *Cotton plugs* are used so much in bacteriological work because they permit a free circulation of air and gases and at the same time act as filters to keep out the bacteria of the air.

Sugar broths or other media in which gas may be produced are used in fermentation tubes (Smith tubes) of the type shown in Fig. 117, so that the gas may be collected in the closed arm of the tube, measured (Fig. 118) and tested if desired.

One method of using gelatin and also agar is as "puncture" or "stab" cultures. The tubes (the narrower tubes

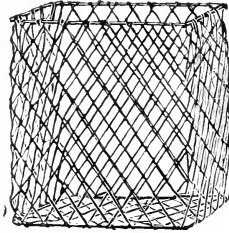
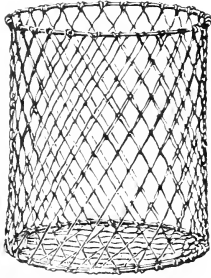

FIG. 114.—Round wire basket. FIG. 115.—Square wire basket.

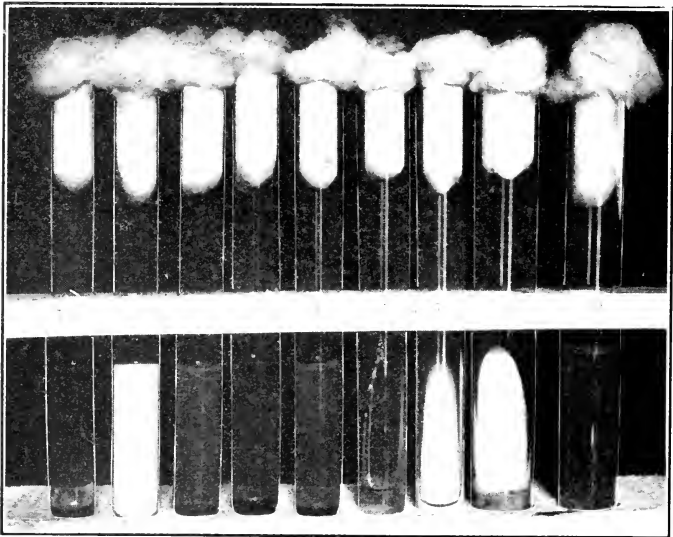

FIG. 116.—Culture tubes with media in them.  $\times \frac{2}{5}$ . 1 to 7 are the smaller tubes mentioned in the text; 9 the larger tube; 8 is extra large for potato tubes; 1, plain broth; 2, plain milk; 3, litmus milk; 4, gelatin for "stab" or "puncture" culture; 5, agar for "stab" or "puncture" culture; 6, agar for "slope" or "slant" culture; 7, blood serum; 8, potato tube; 9, agar for plating. Note the transparency of the broth and gelatin and the slight opalescence of the agar.

are to be preferred for most "stab" cultures) are filled one-third full of the medium while it is still fluid, plugged, sterilized, and allowed to cool in the vertical position. The medium is then "inoculated" with a *straight* platinum needle by plunging this into the center of the surface down to the bottom of the tube (Fig. 116, Nos. 4 and 5).

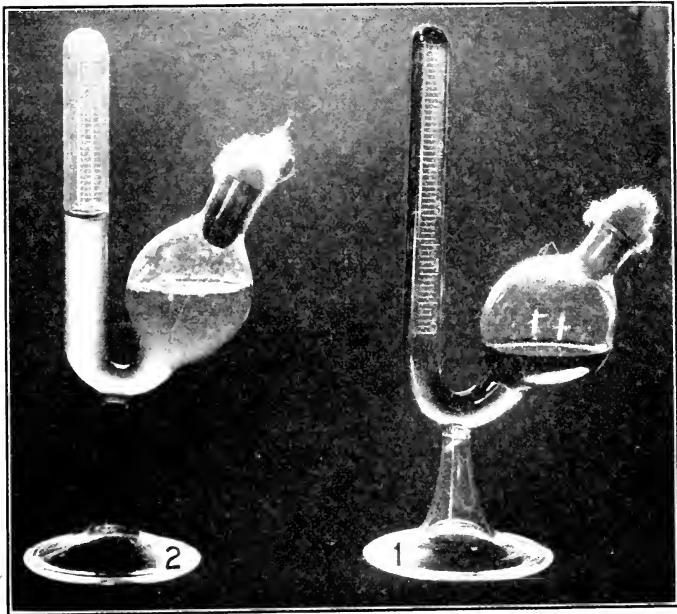

FIG. 117.—Fermentation tubes. 1, filled ready for use; 2, shows a cloudy growth and the development of gas in the closed arm.

Agar and blood serum are frequently used in the form of "slope" or "slant" cultures. That is, the medium solidifies with the tubes lying on their sides which gives a long, sloping *surface* on which the bacteria are inoculated (Fig. 116, Nos. 6 and 7).

Potato tubes are likewise used for "slant" or slope" cultures (Fig. 116, No. 8). Potatoes as "plate cultures" have been referred to. Agar and gelatin are very largely

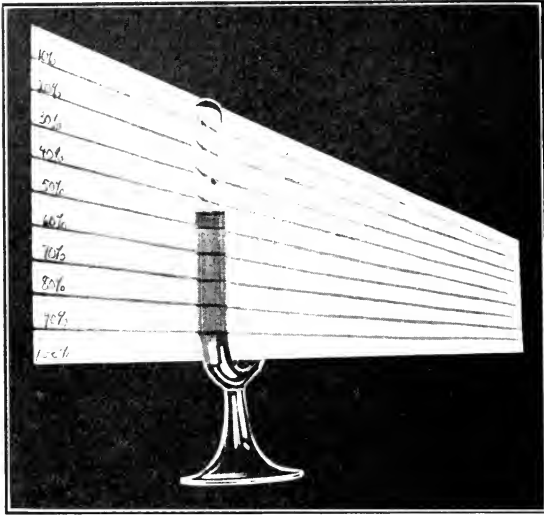

FIG. 118.—Method of estimating percentage of gas in a fermentation tube by means of the "gasometer," the reading is 45 per cent.



FIG. 119.—A toxin flask showing a large surface growth.

used in the form of "plate cultures" also. For this purpose Petri dishes are first sterilized, then the melted agar or gelatin poured into them and allowed to "set" while the plates are kept horizontal. The melted media may be "inoculated" before they are poured, or a portion of the material to be "plated" may be placed in the dish, then the melted medium poured in and distributed over the dish by tilting in various directions, or the medium after solidifying may be inoculated by "strokes" or "streaks" over its surface, according to the purpose in view in using the plate. The larger sized tubes should be used for making plates in order to have sufficient medium in the plate (No. 9, Fig. 116).

For using large quantities of medium, Florence flasks, Ehrlenmeyer flasks, special toxin flasks (Fig. 119) or various other devices (Vaughan and Novy's "mass cultures," Figs. 120 and 121) have been employed.

For growing *anaërobic organisms* it is evident that some method for removing and excluding the oxygen of the air must be used. A very great variety of appliances have been devised for these purposes. Some are based on the principle of the vacuum, exhausting the air with an air pump; some on replacing the air with a stream of hydrogen; others on absorbing the oxygen by chemical means, as with an alkaline solution of pyrogallic acid, or even by growing a vigorous *aërobe* in the same culture or in the same container with the *anaërobe*, the *aërobe* exhausting the oxygen so that the *anaërobe* then develops, or finally by excluding the air through the use of deep culture tubes well filled with the medium, or in the closed arm of fermentation tubes. For many purposes a combination of two or more of the above methods gives good results.

In any event the culture medium should have been *freshly sterilized* just before use, or *should be boiled* in order to drive out the dissolved oxygen. For most *anaërobes* the presence in the medium of about 1 per cent of a carbohydrate, as dextrose, is advisable.

A description of all the various devices is unnecessary in this work, but the following have answered most of the purposes of general work in the author's laboratories.

A. "*Vignal tubes*," of the style shown (Fig. 122), are made from glass tubes of about 6 to 8 mm. outside diameter,

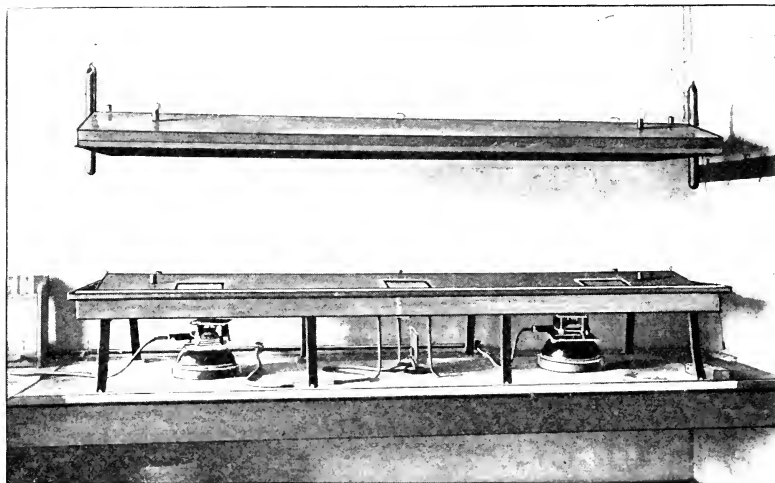

FIG. 120.—Tank with raised lids. (Vaughan.)

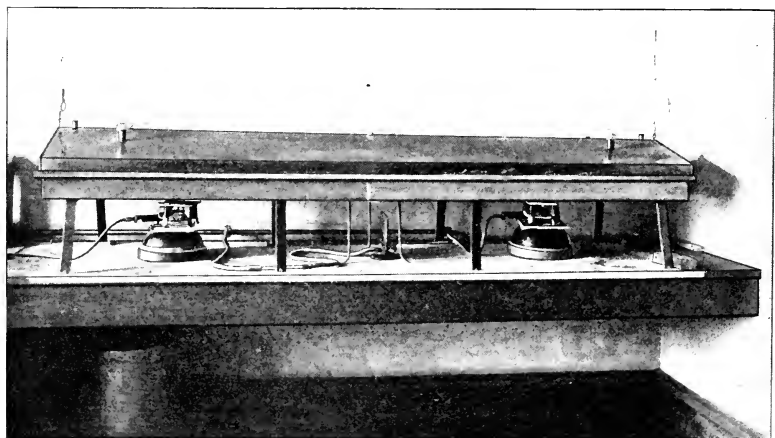

FIG. 121.—Tank with lids lowered. (Vaughan.)

FIGS. 120 and 121.—Vaughan and Novy's mass culture apparatus.



sealed at the small end, plugged with cotton above the constriction and sterilized. The medium, agar or gelatin, which has been previously inoculated with the anaërobic culture, is then drawn up into the tube, after breaking off the tip, as far as the constriction. The tube is then sealed in the flame at the small end and also at the constriction. Since it is full of the medium and sealed, access of air is prevented. This forms an excellent means for "isolation" (Chapter XVIII); the tube needs merely to be cut with a file at the point where colonies appear, then these may be readily transferred.

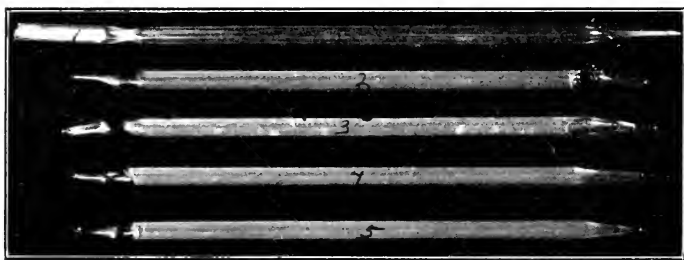

FIG. 122.—Vial tubes.  $\times \frac{1}{3}$ . 1, the sterile tube ready for inoculation; 2, fourth dilution tube showing a few isolated colonies, one near the figure; 3, third dilution showing colonies isolated but numerous; 4, second dilution tube showing colonies still more numerous; 5, first dilution tube showing colonies so numerous and small as to give a cloudy appearance to the tube. In use tube 2 would be filed in two at the colony and inoculations made from it.

B. "*Fermentation tubes*" form a simple means for growing liquid cultures of anaërobes, the growth occurring in the closed arm only, while with facultative anaërobes, growth occurs both in the closed arm and in the open bulb. A little "paraffin oil" (a clear, heavy petroleum derivative) may be poured on the fluid in the open bulb as a very efficient seal, though it is not usually necessary.

C. "*Deep Culture Tubes.*"—The medium, agar, gelatin or a liquid is poured into tubes until they are approximately one-half full, a little paraffin oil is poured on the surface (not essential always), then the tubes are plugged and steril-

ized. Inoculation is made to the bottom and anaërobes grow well (Fig. 123).

*D.* For slope or plate, or any type of surface cultures the Novy jar (Fig. 124) is the most practical device. It is good practice to combine the vacuum method, the hydrogen

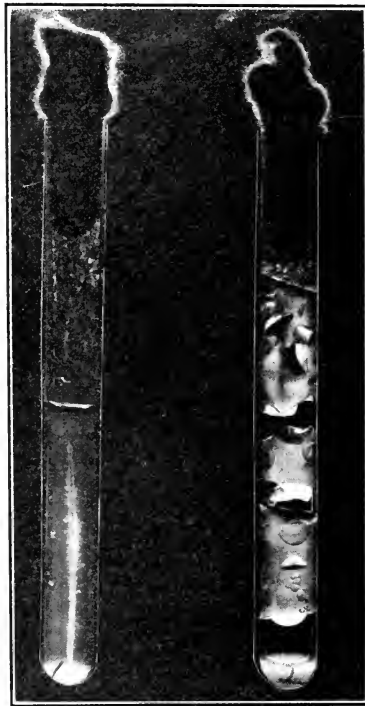

FIG. 123.—Deep tubes showing anaerobic growth. 1, shows a few small gas bubbles; 2, shows the medium broken up by the excessive development of gas.

replacement method and the oxygen absorption method in using these jars. In operation a solution of 20 per cent NaOH is poured on the bottom of the jar to a depth of 1 or 2 cm., the cultures are placed on glass supports above the alkali and a short wide tube of strong pyrogallol is set in on the bottom in such a way that it may be easily upset

and mixed with the alkali when it is desired to do so. The cover is now clamped in position with all joints well vased. Then the outlet tube is connected with a suction pump and the air drawn out. Meanwhile the inlet tube has been connected with a hydrogen generator, and after the jar is exhausted hydrogen is allowed to flow in, and this process is repeated until one is satisfied that the air is replaced. The suction exhausts the air from the tubes or plates so that much less time is required to replace the air with hydrogen. Finally the stop-cock is closed, and the pyrogallol solution is gently shaken down and mixed with the alkali so that any remaining oxygen will be absorbed.

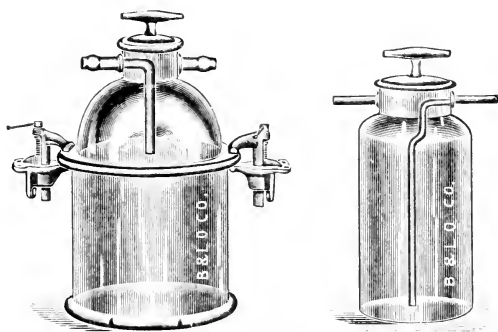

FIG. 124.—Novy jars.

It must be remembered that facultative anaërobes as well as anaërobes will grow under any of the above conditions, so that cultures of organisms so obtained must be further tested aëroically in order to determine to which group the organisms belong.

Reference has been made above to the “inoculation” of culture media, which means introducing into the medium used the desired material in the proper way. For small quantities this is most conveniently done with platinum “needles,” that is, pieces of platinum wire inserted into the ends of glass rods. The “straight” needle is a piece of heavy platinum wire of about 0.022 inch in diameter (Fig. 125). It is used most frequently to inoculate all forms of

*solid media.* The platinum loop is of lighter wire, 0.018 inch. The loop in the end is conveniently made by twisting the wire around the lead of an ordinary lead-pencil. The "loop needle" (Fig. 126) is most used in transferring liquid media. On account of the high price of platinum the author has substituted "nichrome" wire for student use. This is stiffer, not so easily made into loops and breaks out of the rods more easily. The latter defect is remedied by inserting the wire into the end of an aluminum rod. The low cost, less than one-twentieth of platinum, justifies its use.



FIG. 125.—Straight needle.

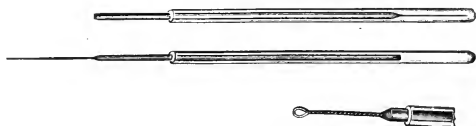

FIG. 126.—Straight and loop needles.

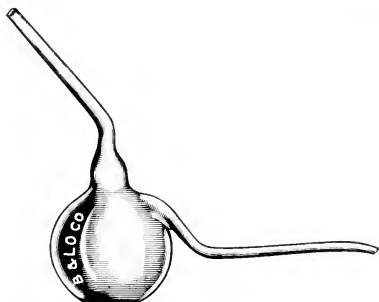

FIG. 127.—Pasteur flask—"balloon pipette."

Sterile graduated pipettes varying in capacity from 1 cc graduated in hundredths, upward, permit the transfer of definite amounts of liquids. Large quantities are conveniently transferred by means of Pasteur flasks (Fig. 127). The details of inoculation are best derived from laboratory practice.

## CHAPTER XVIII.

### ISOLATION OF BACTERIA IN PURE CULTURE.

As has been stated, the thorough study of a bacterium depends on first getting it in pure culture. In the early days of bacteriology supposedly pure cultures were obtained by (1) *dilution in liquid media*. A series of tubes or flasks containing sterile liquid media was prepared. Number one was inoculated with the material to be examined and thoroughly mixed. A small portion of the mixture was transferred to number two and mixed; from this to number three and so on until a sufficient number were inoculated, the last three or four in the series receiving the same amounts of a very high dilution of the original material. If one or two of these latter showed a growth and the others not, it was assumed that the dilution had been carried so far that only a single organism was transferred and therefore the culture obtained was "pure." The method in this crude form is too uncertain to be of value today and recourse is had to more exact means. The procedure most widely used is that of (2) "*plating out*" by means of gelatin or agar plates. The material to be plated out is diluted by transferring to three or more tubes of melted gelatin or agar as in the first method and then all the tubes are poured into Petri dishes and grown under suitable conditions. By proper mixing in the tubes the bacteria are well scattered through the medium which holds the individual organisms separate when it solidifies. On some of the plates a sufficient dilution will be reached so that the colonies developing from the bacteria will be so few that they are separate and pure cultures may be obtained by inoculating from one of these a tube of the appropriate medium (Figs. 128 to 131). The chief uncertainty with this method is that occasionally

two kinds of bacteria stick together so closely that even the separate colonies contain both organisms. This is not common, however. The plate colonies frequently develop

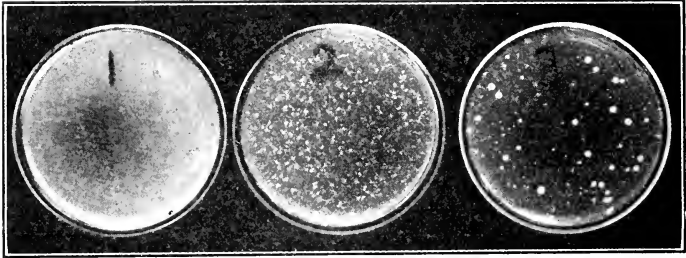

FIG. 128.—Dilution plates.  $\times \frac{3}{10}$ . 1, shows the first dilution, the colonies are so numerous and small that they are invisible (compare Fig. 129); 2, shows fewer and hence larger colonies, but too crowded to isolate (compare Fig. 130); 3, shows the colonies larger and well separated, so that it is easy to isolate from them (compare Fig. 131).

from groups of bacteria which were not separated, but as these are of the same kind the culture is essentially pure.

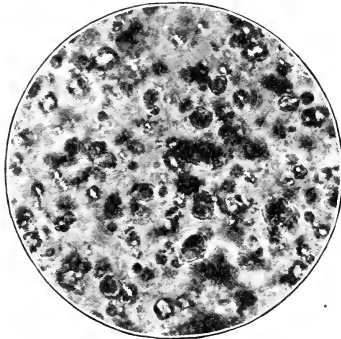

FIG. 129.—A portion of plate 1 in Fig. 128 as seen under the low-power objective.  $\times 100$ . Very small, closely crowded colonies.

Another method which is frequently applicable with material from human or animal sources is to (3) *rub the material over the surface* of a slope tube or of medium solid-

ified in a Petri dish with a sterile heavy platinum needle, glass rod or cotton swab. If the bacteria are not too numerous, pure cultures may frequently be obtained. A modification of this method is to make a series of (4) *parallel streaks on a slope tube or plate of medium* with a needle inserted *but once* into the material to be plated. On the first streak most of the bacteria are rubbed off and a continuous growth results, but usually on the last of a series only isolated colonies appear, which are presumably pure. The ideal method for securing pure cultures is to be absolutely certain that the culture starts from a single organism.

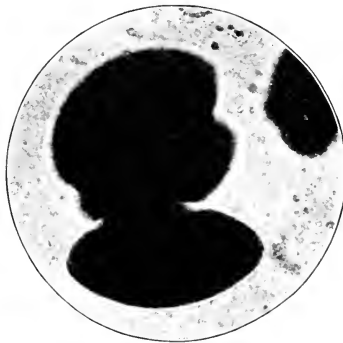

FIG. 130.—From the thinnest part of plate 2, Fig. 128, as seen under the low-power objective.  $\times 100$ . Colonies much larger than on plate 1, but still crowded.



FIG. 131.—The smallest colony on plate 3, Fig. 128, as seen under the low-power objective.  $\times 100$ . Large, single, isolated colony.

This may be accomplished by means of the (5) *apparatus and pipettes devised by Professor Barber* of the University of Kansas (Figs. 132 and 133). With this instrument a single organism is picked out under the microscope and isolated in a drop of culture medium and observed until it is seen to divide, thus proving its viability. Transfers are then made to the proper media. The method requires much practice to develop the necessary skill in the making of pipettes, determining the proper condition of the large cover-glasses used over the isolating box, and in manipulation, but the results fully compensate.

Professor W. A. Starin of the author's department, a former student of Professor Barber, has done some excellent work with this apparatus.

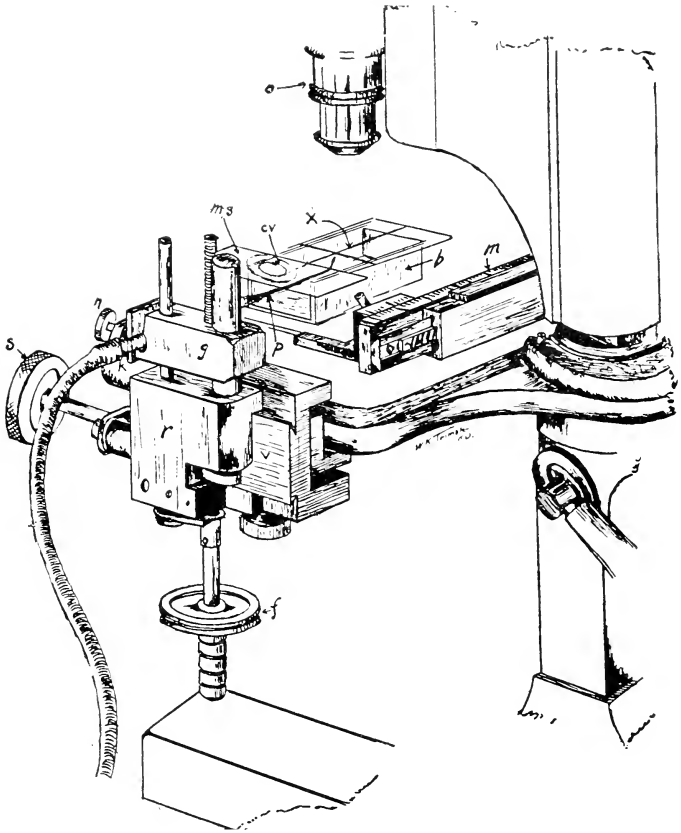

FIG. 132.—Diagram of Barber's isolation apparatus. *b*, moist chamber; *ms*, large cover-glass over moist chamber; *p*, small pipette drawn out to a fine point; *k*, *r*, *g*, pipette holder; *f*, screw for raising and lowering *k*, *r*, *g*; *s*, screw for lateral motion of *k*, *r*, *g*; *n*, screw for clamp on pipette which allows it to be moved in or out; *m*, mechanical stage of microscope; *t*, rubber tube held in the mouth and used to move the liquid culture medium in the pipette. (Journal of Infectious Diseases, October 20, 1908, 5, No. 4, 381.)



A number of procedures may be used to greatly facilitate the above methods of isolation by taking advantage of the different physiological properties of different organisms in a mixture such as ability to form spores, different resistance to antiseptics, special food requirements and pathogenic

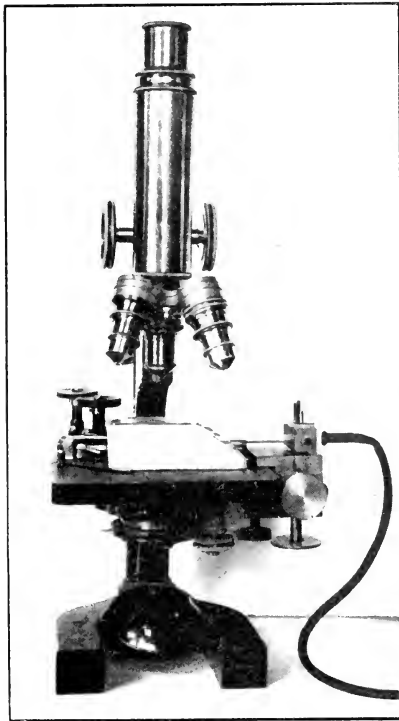

FIG. 133.—Photograph of microscope with Barber's isolation apparatus set up to use.

properties. (a) If material contains resistant spores it may be heated to temperatures high enough to kill all of the organisms except the spores ( $80^{\circ}$  for half an hour, for example) and then plated out. Or (b) an antiseptic which restrains the growth of some organisms and not others may be placed

in the culture media (carbolic acid, various anilin dyes, (page 148), excess acid, or alkali, ox bile, etc.), when the more resistant organisms grow on the final plates, the others not. (c) *Special food substances* (various carbohydrates) from which the organism desired forms special products (acids, aldehydes) that may be shown on the plates by various indicators is one of the commonest means. Or media in which certain organisms thrive and others not, so that the former soon "crowd out" the latter (unsterilized milk for lactic acid bacteria, inorganic media in soil bacteriology) may be used. A combination of the general methods (b) and (c) is much used in the separation of the organisms of the "intestinal group" in human practice. (d) *The inoculation of a susceptible animal* with a mixture suspected to contain a given pathogenic bacterium frequently results in the development of the latter in pure culture in the body of an animal, from which it may be readily recovered. In all of the above methods (except Barber's) the first "pure culture" obtained should be "purified" by replating in a series of dilution plates to make sure that it is pure.

## CHAPTER XIX.

### STUDY OF INDIVIDUAL BACTERIA-STAINING.

WHEN an organism has been obtained in pure culture by any of the methods described in the preceding chapter the next step is the study of its morphology as discussed in Chapters II-IV. This involves the use of the microscope, and since bacteria are so small, objectives of higher power than the student has presumably used will be needed. Doubtless only the  $\frac{2}{3}$ -inch or 16 mm. and the  $\frac{1}{6}$ -inch or 4 mm. objectives are all that have been used in previous microscopic work, while for examining bacteria a  $\frac{1}{12}$ -inch or 2 mm. is necessary. It will have been observed that the higher the power of the objective the smaller is the front lens or object glass and consequently the less is the amount of light which enters. With the use of the  $\frac{1}{12}$ -inch or 2 mm. objective it is necessary to employ two devices for increasing the amount of light entering it, with which the student is probably not familiar. One of these is to place a drop of cedar oil between the front lens and the object and to immerse the lens in this oil—hence the term “oil-immersion objective”; the other is the substage or Abbé condenser. The latter is a system of lenses placed below the stage and so constructed as to bring parallel rays of light—daylight—from an area much larger than the face of the front lens of the objective to a focus on the object to be examined, thus adding very greatly to the amount of light entering the objective. Since the condenser brings *parallel* rays to a focus on the object the *flat mirror* is always used with the condenser when working with daylight. With *artificial light close* to the microscope, the concave mirror may be used to make the divergent rays more nearly parallel and thus give better illumination.

The function of immersion oil is to prevent the dispersion

of considerable light that would otherwise occur owing to refraction as the light passes up through the slide and into the air. The accompanying diagram will help to make this clearer (Fig. 134). A ray of light ( $A B$ ) coming through the slide will be refracted in the direction  $B C$  if the medium has a lower refractive index than the slide, as air has, and hence will not enter the objective  $O$ . If, however, there is interposed between the objective and the slide a medium which has the same refractive index as the slide, as immersion oil has, then the ray will continue in the same direction ( $B D$ ) at the point  $B$  and hence enter the objective. Evi-

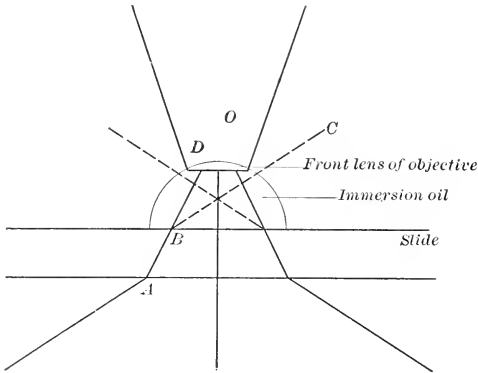

FIG. 134.—Diagram of use of immersion oil.

dently the immersion oil causes much more light to enter the front lens and makes the field brighter and at the same time prevents considerable refraction and dispersion of light from the object seen and hence this appears more distinct and sharply defined. The Abbé condenser and the oil-immersion objective are practically always used in the microscopic study of bacteria (Fig. 135).

### HANGING DROP SLIDE.

It is sometimes necessary to examine living bacteria, and for this purpose the device known as the "hanging drop

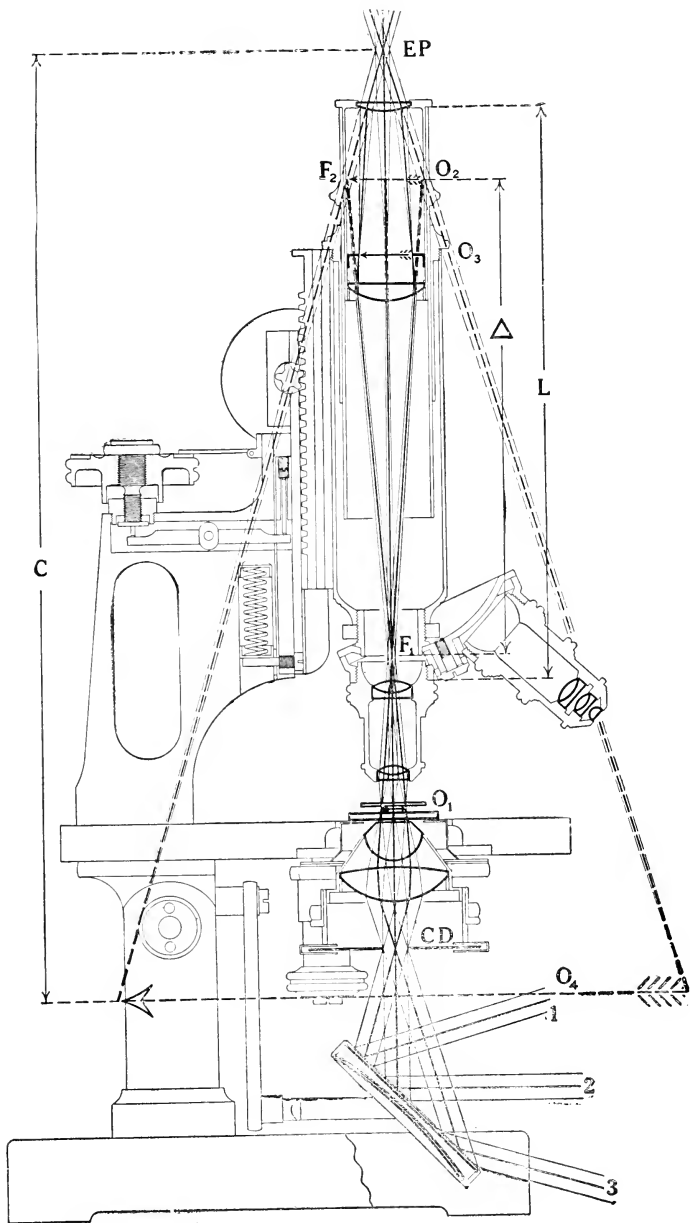

FIG. 135.—Diagram of paths of rays of microscope.

slide" is used (Fig. 136). The slide has a slight concave depression ground in the middle of one face. A ring of vaseline is placed around this depression with the loop needle. On a clean cover-glass, large enough to fit over the ring of vaseline, several drops of a broth culture or of material from a solid culture suspended in broth or physiological normal salt solution are placed. The slide is inverted on the cover-glass in such a way that the ring of vaseline seals the latter to the slide. When the whole preparation is quickly turned, cover side up, the drops are seen "hanging" to the under side of the cover over the depression in the slide. In examining such a preparation with the microscope great care is necessary in order to focus on the bacteria without breaking the cover. To see the organisms distinctly the *lower iris diaphragm of the condenser must be nearly closed*, so that the light coming through consists



FIG. 136.—Hanging drop slide.

mainly of parallel vertical rays, otherwise the transparent bacteria themselves refract and diffract the light and appear blurred and indistinct. By studying living bacteria with this device it can be determined whether they are motile or not. The motility should not be confounded with the familiar "Brownian movement" of all minute insoluble inert particles which non-motile living bacteria and also dead bacteria show. The hanging drop slide is of value in the measurement of bacteria, since this is properly done on the living organism. Measurement is done with a calibrated ocular micrometer as in other kinds of measurement with the microscope with which the student is presumably familiar. The direct effect of various agents on living bacteria, as light, electricity, heat, etc., in the study of "tropisms" and "taxes" has been investigated on various modifications of the above-described hanging drop slide.

Cell forms and cell groupings may be studied in the same

way, but these features are best determined on *stained* preparations in many instances.

“Dark field” illumination and the ultramicroscope are of great value in the study of living bacteria and other minute objects, but apparatus of this type would scarcely be used by the student in an introductory course, so that they will not be discussed in the present volume.

### STAINING.

The main use of the microscope in bacteriology is in the study of *stained preparations* of the organisms. Staining makes bacteria opaque and hence more easily seen than the transparent unstained forms. Some methods of staining also show morphological structures which are either imperfectly recognized in the unstained cell, spores, or are not visible at all—capsules, metachromatic granules, flagella. Finally certain bacteria are colored by special methods of staining which do not affect others, so that under proper conditions these bacteria may be recognized by staining methods alone—tubercle bacilli in the organs of animals.

The phenomena of staining are essentially chemical, though sometimes the chemical union is a very weak one, even resembling an absorption of the dye rather than true chemical union—most watery stains. In other cases the chemical compounds formed are decidedly stable and are not decomposed even by strong mineral acids—staining of tubercle bacilli and other “acid-fast” organisms. In still other cases the principal action is a precipitation on the surface of the object stained—methods for staining flagella.

In many methods of staining in addition to the dyes used other substances are added to the solution which assist in fixing the dye in or on the organism stained. Such substances are called *mordants*. The principal mordants used are alkalies, anilin, carbolic acid, iodine, metallic salts, tannic acid.

While it is true that some bacteria may be stained by that standard histological nuclear dye, hematoxylin, it is of little value for this purpose. Practically all bacteriological stains

are solutions of the *anilin dyes*. These dyes, as is well known, are of nearly every conceivable color and shade but relatively very few are used in bacteriological work. The beginning student will rarely use solutions of other than the three dyes *fuchsin* (red), *methylene blue* and *gentian violet* for staining bacteria, with occasionally Bismarck brown, or eosin, or safranin as tissue contrast stains.

The bacteriological dyes are kept "in stock" as saturated solutions in 95 per cent alcohol, which are *never used as stains* but merely for convenience in making the various staining solutions.

The approximate percentages of the three common dyes in such solutions are indicated in the following table adapted from Wood's *Chemical and Microscopical Diagnosis*, third edition, 1917, Appendix:

Fuchsin . . . . .	3.0 per cent.
Gentian violet . . . . .	4.8 "
Methylene blue . . . . .	2.0 "

The stains made from these dyes which are in most common use are the following:

### 1. Aqueous (watery) gentian violet solution.

Saturated alcoholic solution of gentian violet . . . . .	1 part
Distilled water . . . . .	20 parts

Mix well and filter.

### 2. Anilin gentian violet:

Saturated alcoholic solution of gentian violet . . . . .	1 part
Anilin water (see below) . . . . .	10 parts

Mix well and filter.

### 3. Anilin fuchsin:

Saturated alcoholic solution of fuchsin . . . . .	1 part
Anilin water (see below) . . . . .	10 parts

Mix and filter.

These stains rarely keep longer than ten days in the laboratory (unless kept in the ice-box) and must be made fresh on the first sign of a deposit on the glass of the container.



**Anilin Water.**—Anilin water is made by putting 3 or 4 cc of anilin “oil” in a 120 cc flask, adding 100 cc of distilled water, shaking vigorously for a minute or so and filtering through a wet filter—in other words, a saturated solution of anilin in water.

4. Löffler's (methylene) blue:

Saturated alcoholic solution of methylene blue . . . . .	3 parts
Aqueous solution of NaOH (or KOH), 1 to 10,000 . . . . .	10 “

5. Carbol-fuchsin (Ziehl's solution):

Saturated alcoholic solution of fuchsin . . . . .	1 part
5 per cent aqueous solution of carbolic acid . . . . .	10 parts
Mix and filter.	

6. Gabbet's (methylene) blue (solution):

Dry methylene blue . . . . .	4 parts
Concentrated $H_2SO_4$ . . . . .	25 “
Distilled water . . . . .	75 “
Dissolve the dry dye in the acid and add the solution to the distilled water and filter.	



FIG. 137.—Author's staining set. Square bottles are set in square holes in the block. The capacity of each bottle is 30 cc.

Staining solutions are conveniently kept in square dropping bottles inserted in a block as shown in Fig. 137. This

form of holder necessitates the use of *one hand only* in securing the stain and dropping it on the preparation.

The actual staining of bacteriological preparations can be learned only by repeated laboratory practice, yet the following methods have given such uniform results in class work that it is felt they are not out of place in a text-book.

**Preparation of the "Film."**—The author learned to stain bacteria on the "cover-glass," but does not recall having used this method in fifteen years and does not teach it to his students. All staining is done on the slide. To prepare a film from a solid culture medium the procedure is as follows:

First, be sure the slide is clean and *free from grease*. This is accomplished most readily by scouring a few minutes with finely ground pumice stone and a little water, then washing and drying with a grease-free cloth, handkerchief or piece of cheese-cloth. With the "loop" needle place in the middle of the slide a small loop of water. This is best done by filling the loop by dipping in water, then tapping it gently so that all that remains is the water that just fills the loop level full, and this amount is placed on the slide by touching the flat side of the loop to the glass. Then the *straight needle* is sterilized, dipped into the culture and just touched once into the small drop of water on the slide. The remainder of the culture on the straight needle is then burned off and the needle is used to spread the drop of water containing the bacteria into a thin even film, which will result, provided the slide is free from grease. This is dried and then "fixed" by passing three times through the Bunsen flame at intervals of about one second, passing through slowly for thick slides and a little more rapidly for thin ones. If the culture is in a liquid medium, the use of the loop of water is unnecessary; a loop of the fluid from the surface, middle or bottom as the culture indicates, is spread out to a thin film dried and fixed.

After the film is fixed the stain desired is dropped on, allowed to act for the proper time, which will depend on the stain and the preparation, washed in water, dried thoroughly and examined with the oil-immersion lens, without a cover.

If it is desired to preserve the preparation it may then be mounted in balsam. This is not necessary, as they keep just as well, provided the immersion oil is removed. To do this, fold a piece of filter paper so that at least three thicknesses result. Lay this on the slide and press firmly several times, when the surplus oil will be taken up by the paper. Slides not mounted in balsam are more apt to become dusty than those that are. This is the only disadvantage.

**Gram's Method of Staining.**—It has been ascertained that some bacteria contain a substance, possibly a protein, which forms a compound with gentian violet and iodine, which compound is insoluble in alcohol, and other bacteria do not contain this substance. Consequently when bacteria are stained by Gram's method (given below), those that contain this chemical remain colored, while if it is not present the dye is washed out by the alcohol and the bacteria are colorless and may be stained by a contrast stain. The bacteria which stain by this method are said to "take Gram's" or to be "Gram-positive," while those that decolorize are called "Gram-negative." The method is:

1. Prepare the film as above given.
2. Stain with fresh anilin gentian violet one minute.
3. Wash in tap water.
4. Cover with Gram's solution one minute.
5. Wash in tap water.
6. Wash with 95 per cent alcohol three times or until no more color comes out.
7. Dry and examine.

Gram's solution is:

I	. . . . .	1 part
KI	. . . . .	2 parts
H <sub>2</sub> O	. . . . .	300 "

This method is excellent for differentiating Gram-positive and Gram-negative organisms on the same slide. First stain by this method and after washing with alcohol stain with a counterstain, carbol-fuchsin diluted ten to fifteen times with water is excellent. The Gram-positive bacteria are violet and the Gram-negative are red.

It is also of great value in staining Gram-positive bacteria in tissues, but the sections should be stained about five minutes in the anilin gentian violet and be left about two minutes in the Gram's solution. Sections are to be counterstained in Bismarck brown, dilute eosin or safranin solutions and cleared in oil of bergamot, lavender or origanum and not in clove oil or carbol-xytol, as these latter dissolve out the dye from the bacteria.

**Staining of Spores in the Rod.**—Prepare the films as usual. Cover with carbol-fuchsin, using plenty of stain so that it will not dry on the slide; heat until vapor arises, not to boiling; cool until the stain becomes cloudy and heat again until the stain clears, and repeat once more; wash in tap water and then wash in 1 per cent  $H_2SO_4$  three times, dropping on plenty of acid, tilting and running this over the slide three times and then pour off and use fresh acid and repeat this once. Wash thoroughly in *distilled* water, then stain with Löffler's blue one to three minutes. Wash, dry and examine. The spores should be bright red in a blue rod.

This method will give good results if care is taken to secure cultures of the right age. If the culture is too old the spores will all be free outside the rods, while if too young they will decolorize with the acid. For *Bacillus subtilis* and *Bacillus anthracis*, cultures on agar slants forty-eight hours in the  $37^\circ$  incubator are just right. For the spores of *Clostridium tetani* the culture should be three days old, but may be as old as a week.

**Staining of "Acid-fast" Bacilli.**—*Mycobacterium tuberculosis*, *Mycobacterium of Johne's disease*, "grass" and "butter bacilli," *Mycobacterium lepræ*, *Mycobacterium smegmatis*.

*Gabbet's method:*

1. Prepare the film as usual.
2. Stain with carbol-fuchsin as given above for spores.
3. Wash with tap water.
4. Decolorize and stain at the same time with Gabbet's blue, two or three minutes.
5. Wash, dry and examine.

The sulphuric acid in Gabbet's blue removes the carbol-fuchsin from everything except the "acid-fast" bacteria, which remain red, and the blue stains the decolorized bacteria and nuclei of any tissue cells present.

*Ziehl-Neelson method:*

- 1, 2, 3, as in Gabbet's method.
4. Decolorize with 10 per cent HCl until washing with water shows only a faint pink color left on slide.
5. Wash thoroughly.
6. Stain with Löffler's blue one or two minutes.
7. Wash, dry and examine.

The results are the same as with Gabbet's method.

**Staining of Capsules.** *Rübiger's Method.*—Films of the organism to show capsules should be *freshly prepared, dried but not fixed*. Material is usually obtained from milk or blood. A drop of the fluid is placed on the middle of a slide about one-fourth of the distance from one end. The narrow edge of another clean slide is placed in this drop and then drawn lengthwise across the slide with firm pressure. This gives a *thin layer* which is necessary if good results are to be expected. The preparation is covered with a *freshly prepared* saturated solution of gentian violet in formalin and this is allowed to stain for thirty seconds. Then wash *lightly*, dry and examine. The organisms appear deeply violet and much larger than with ordinary stains and capsules are well stained and show well.

*Welch's Method.*—Prepare films as in the above method. *Immediately* after the film is prepared cover with glacial acetic acid for ten to twenty seconds. Wash off the acid with carbol-fuchsin. Wash the stain off with physiological normal salt solution (0.85 per cent) until all surplus stain is removed. Dry and examine. Capsules and bacteria are red.

**Staining of Flagella.**—The rendering of flagella visible is considered one of the most difficult processes in staining. Experience of a number of years, during which whole classes numbering from 100 to 300 students accomplish this result, shows that it is no more difficult than many other staining processes. The essentials are: (1) clean slides, (2) young cultures on agar slopes, (3) freshly prepared mordant and

stain which are kept free from precipitate, (4) gentle heating. The author's students are furnished only stock materials and make their own cultures, mordants and stains.

The slides are cleaned with pumice in the usual way. An agar slope culture of the organism to be stained from six to twenty-four hours old is selected. A bit of the culture is removed and placed in a watch-glass of water. The bacteria are allowed to diffuse of themselves without stirring. After several minutes a loop of this water is removed and three streaks are made across the slide, one in the middle and one on each side of this about one-quarter of an inch from it. This gives well scattered bacteria in one of the three streaks at least and very little other material on the slide to cause precipitates. The slide is carefully dried and fixed and then covered with an abundance of the mordant by filtering through a small filter onto the slide so that the mordant shows transparent on the slide. The preparation is then gently warmed and cooled three times, adding mordant if necessary. *Do not heat to steaming.* After mordanting for about five minutes the excess is washed off under the tap. It is a good plan to hold the slide level and allow the water to run into the center of the mordant and flow it off. Inclining the slide is apt to cause the film on the surface of the mordant to settle down on the slide and spoil the preparation. After the mordant is washed off and all traces of it removed with a clean cloth if necessary the stain is applied and gently heated and cooled the same way for from three to five minutes. The preparation is then washed, dried and examined.

The mordant used is a modification of Löffler's, which is somewhat simpler in preparation, since the stock solution of  $\text{FeCl}_3$  is more permanent than  $\text{FeSO}_4$  solution.

Mordant sufficient for one student:

5 per cent solution of $\text{FeCl}_3$ . . . . .	20.0 cc
25 per cent solution of tannic acid . . . . .	20.0 cc
Anilin fuchsin . . . . .	4.0 cc
Normal NaOH . . . . .	1.5 cc

The solution of  $\text{FeCl}_3$  is made up in the cold and must be perfectly clear. The tannic acid solution must be thoroughly boiled and filtered until clear. The iron and the acid

are carefully mixed, boiled and filtered clear. The anilin fuchsin must be added slowly with constant stirring and the mixture boiled and filtered. The NaOH is added in the same way and this mixture boiled and filtered. The final mordant should not leave a film on a clean slide when poured on and allowed to run off. Unless the mordant is in this condition and perfectly clear, it should not be used, but a new one must be made up. Time and care in the preparation of the mordant are essential.

The *pH* of the mordant is most important. An excellent mordant for staining the flagella of *Proteus vulgaris* has a *pH* of 1.03 as determined with a potentiometer.

The stain to follow this mordant is anilin fuchsin.

**Staining of Metachromatic Granules.**—*Neisser's Method.*—Prepare the film in the usual way. Stain with Neisser's stain a few seconds only. Wash and stain with Bismarck brown a few seconds only.

*Neisser's Stain:*

Saturated alcoholic solution of methylene blue . . . . .	1.0 part
Glacial acetic acid . . . . .	2.5 parts
Distilled water . . . . .	50.0 parts

*Bismarck Brown:*

Bismarck brown (dry dye) . . . . .	2 parts
Distilled water . . . . .	1000 parts

By the use of the hanging drop slide and the methods of staining just described all the various morphological features of the bacterial cell may be ascertained.

It is necessary when *cell groupings* as characteristic of definite modes of division are to be determined to make slides from a liquid culture as broth. Place a drop of the material, preferably from the bottom of the tube in most instances, from the top in case a pellicle or scum is formed on the surface, on the slide and allow this to dry *without spreading it out*, fix, wash gently with water, then stain lightly with Löffler's blue. Such slides also show characteristic *cell forms* as well. Slides should be made from solid media to show variations in form and size and involution forms. These latter are especially apt to occur on potato media.

## CHAPTER XX.

### STUDY OF THE PHYSIOLOGY OF BACTERIA.

OF the environmental conditions influencing the growth of bacteria the following are the chief ones ordinarily determined:

*A. Temperature.*—The optimum temperature for growth is usually about the temperature of the natural environment and ordinarily one determines merely whether the organism grows at body temperature ( $37^{\circ}$ ) and at room temperature ( $20^{\circ}$ ) or not. For exact work the maximum, minimum and optimum temperature must be ascertained by growing in “incubators” with varying temperatures:

A bacteriological incubator is an apparatus for growing bacteria at a constant temperature. This may be any temperature within the limits for bacterial growth. If temperatures above that of an ordinary room are desired, some source of artificial heat is needed. Electricity, gas or oil may be used. A necessary adjunct is some device for maintaining the temperature constant, a “thermoregulator” or “thermostat.” For lower temperatures a cooling arrangement must be installed. For the great part of bacteriological work only two temperatures are used,  $20^{\circ}$  so-called “room temperature” (this applies to European “rooms” not to American) and  $37^{\circ}$  or body temperature. Incubators for  $37^{\circ}$  of almost any size and style desired may be secured from supply houses and need not be further described. Figs. 138 and 139 illustrate some of the types.

For use with large classes “incubator rooms” are to be preferred. The author has one such room for  $37^{\circ}$  work with 200 compartments for student use which did not cost over \$60 to install.

The styles of incubators for lower temperatures,  $20^{\circ}$  and below, are not so numerous nor so satisfactory. The author



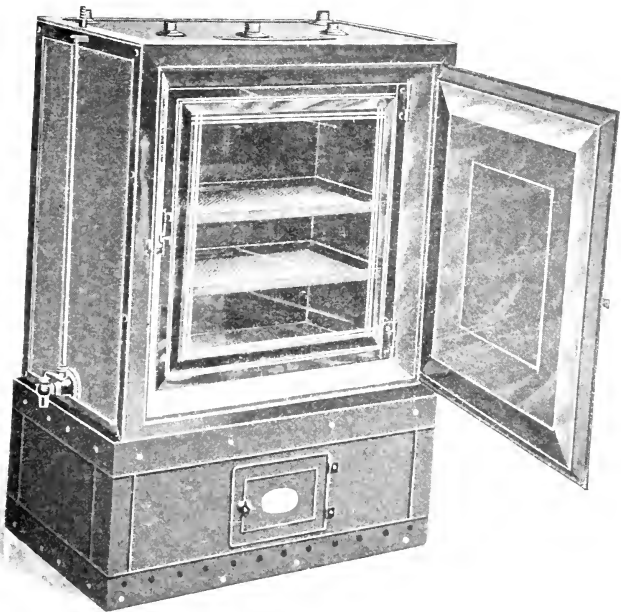

FIG. 138.—Small laboratory incubator, gas heated.

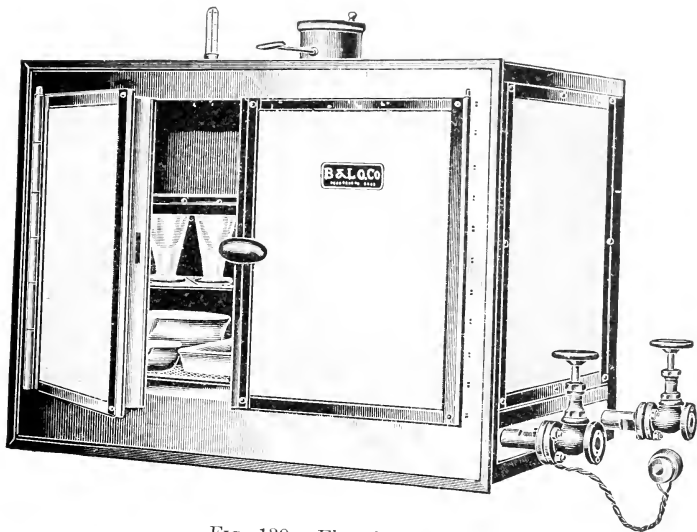

FIG. 139.—Electric incubator.

has constructed a device which answers every purpose for a small class. The diagram, Fig. 140, explains it.

The thermal death-point is determined by exposing the organisms in thin tubes of broth at varying temperatures for ten-minute periods and then plating out to determine

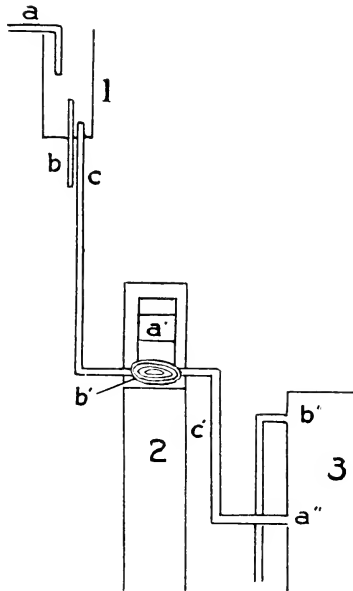

FIG. 140.—Diagram of fittings for a cold incubator. 1, small tank for constant head, about one foot in each dimension: *a*, inflow; *b*, overflow; *c*, lead pipe. 2, refrigerator: *a'*, ice; *b'*, flat coil under ice; *c'*, outflow to incubator. 3, incubator: *a''*, cold water inflow; *b''*, overflow; thermometer and burner omitted. The diagram explains the construction. The water cooled to about 14° with artificial ice by flowing through the lead coil under the ice flows into the incubator, which may be heated and regulated in the usual way.

growth. The effect of heat may also be determined by exposing at a given temperature, *e. g.*, 60° for varying lengths of time and plating out.

*B. Oxygen relations*—whether the organism is aerobic, anaerobic or facultative is determined by inoculation in

gelatin or agar puncture or stab cultures and noting whether the most abundant growth is at the top, the bottom or all along the line of inoculation.

*C.* Reaction of the medium—acid, alkaline or neutral as influencing the rate and amount of growth.

*D.* The kind of medium on which the organism grows best.

*E.* The effect of injurious chemicals, as various disinfectants, on the growth.

*F.* Osmotic pressure conditions, though modifying decidedly the growth of bacteria, are not usually studied as aids in their recognition, nor are the effects of various forms of energy, such as light, electricity, roentgen rays, etc.

Among the "Physiological Activities" discussed in Chapters IX–XII, those which, in addition to the staining reactions described, are of most use in the identification of non-pathogenic bacteria are the first ten listed below. For pathogenic bacteria the entire thirteen are needed.

1. Liquefaction of gelatin.
2. Digestion of blood serum.
3. Coagulation and digestion of milk.
4. Acid or gaseous fermentation in milk, or both.
5. Acid or gaseous fermentation of various carbohydrates in carbohydrate broth, or both.
6. Production of indol in "indol solution."
7. Production of pigments on various media.
8. Reduction of nitrates to nitrites, ammonia, or free nitrogen.
9. Production of enzymes as illustrated in the above activities.
10. Appearance of growth on different culture media.
11. Production of free toxins as determined by injection of animals with broth cultures filtered free from bacteria.
12. Causation of disease as ascertained by the injection of animals with the bacteria themselves, and recovery of the organism from the animals.
13. Formation of specific antibodies as determined by the proper injection of animals with the organism or its products and the subsequent testing of the blood serum of the inoculated animals.

For special kinds of bacteria other activities must be determined (oxidation, nitrate and nitrite formation, action of sulphur and iron bacteria, etc.).

The first nine activities are determined by inoculating the different culture media already described and observing the phenomena indicated, making chemical tests where necessary.

### **APPEARANCE OF GROWTH ON DIFFERENT CULTURE MEDIA.**

In addition to those changes that are associated with the manifestation of different physiological activities, many bacteria show characteristic appearances on the various culture media which are of value in their identification.

Too much stress should not be laid on these appearances alone, however, since slight variations, particularly in solid media due especially to the age of the medium, may change decidedly the appearance of a colony. This is true of variations in the amount of moisture on agar plates. Colonies which are ordinarily round and regular may assume very diverse shapes, if there chance to be an excess of moisture on the surface.



Also in slope and puncture cultures on the various solid media much variation results from the amount of material on the inoculation needle and just how the puncture is made, or the needle drawn over the slope. These variations are largely prevented by the use of standard media and by inoculating by standard methods. The Laboratory Committee of the American Public Health Association has proposed standard methods for all culture media and tests and for methods of inoculation, and these have been generally adopted in this country for comparative work.

Likewise the Society of American Bacteriologists has at different times (1904, 1914, 1917, 1924) adopted "descriptive charts" for detailing all the characteristics of a given organism. One of the charts is inserted in this chapter.

MORPHOLOGY

Underscore required terms.	SKETCHES
<p><b>VEGETATIVE CELLS, medium used</b> .....</p> <p>Reaction ..... temp. .... age ..... days</p> <p>Form, <i>spheres, short rods, long rods, filaments, commas, short spirals, long spirals, curved</i>.</p> <p>Arrangement, <i>single, pairs, chains, fours, clusters, cubical packets</i></p> <p>Limits of length ..... of diameter .....</p> <p>Size of majority .....</p> <p>Ends, <i>rounded, truncate, concave, tapering</i></p> <p>Capsules, present or .....</p> <p>How stained .....</p>	
<p><b>SPOROANGIA, present, absent. Medium used</b> .....</p> <p>Reaction ..... temp. .... age ..... days</p> <p>Form, <i>elliptical, short rods, sporidial, clavate, drum-sticks</i></p> <p>Limits of length ..... of diameter .....</p> <p>Size of majority .....</p> <p>ENDOSPORES, present, absent.</p> <p>Method of examination, in <i>stained or unstained</i> preparations.</p> <p>Location, by what technique?</p> <p>Shape of endospores, <i>central, excentric, subterminal, terminal</i>.</p> <p>Form, <i>spherical, ellipsoid, cylindrical</i>.</p> <p>Limits of size .....</p> <p>Size of majority .....</p> <p>Wall, <i>thick, thin</i>.</p> <p>Sporangium wall, <i>adherent, not adherent</i>.</p>	
<p><b>MOTILITY</b> .....</p> <p>In broth ..... On agar .....</p> <p><b>FLAGELLA, No.</b> ..... Attachment, <i>polar, bipolar, peritrichate</i> How stained .....</p>	
<p><b>IRREGULAR FORMS</b> .....</p> <p>Present on ..... id. .... days at ..... °C.</p> <p>Form, <i>spindled, concave, filamentous, branched, or</i></p> <p><b>STAINING REACTIONS.</b></p> <p>Gram: 1 day ..... 2 day ..... 3 day ..... 4 day .....</p> <p>Acid fast ..... Technique used .....</p> <p>Special stains .....</p>	

CULTURAL CHARACTERISTICS

Underscore required terms	SKETCHES	Underscore required terms
<p><b>Agar</b> .....</p> <p><b>Stroke</b> .....</p> <p>Growth, <i>scanty, moderate, abundant, none</i>.</p> <p>Form of growth, <i>filiform, echinulate, beaded, spreading, arborescent, rhizoid</i>.</p> <p>Elevation of growth, <i>effuse, flat, raised, convex</i>.</p> <p>Lustre, <i>glistening, dull</i>.</p> <p><b>Incubation</b> .....</p> <p>Surface, <i>smooth, contoured, rugose</i>.</p> <p><b>Temperature</b> .....</p> <p>Optical characters, <i>opaque, translucent, opalescent, iridescent</i>.</p> <p>Chromogenesis. Photogenic. <b>Fluorescent</b> (odor, absent, decided, resembling .....</p> <p>Consistency, <i>buttery, viscous, membranous, brittle</i>.</p> <p>Age .....</p> <p>Medium, <i>grayed, browned, reddened, bluish, greened, unchanged</i>.</p>		<p><b>Nutrient Broth</b> .....</p> <p>Surface growth, <i>rag, pellicle, flocculent, membranous, none</i>.</p> <p><b>Clouding</b>, <i>slight, moderate, strong, transparent, persistent, none, fluid, turbid</i>.</p> <p><b>Temperature</b> .....</p> <p>Odor, <i>absent, decided, resembling .....</i></p> <p><b>Sediment</b>, <i>compact, flocculent, granular, flaky, viscous on agitation</i>.</p> <p>Amount of sediment, <i>abundant, scanty, none</i>.</p> <p>Age .....</p>
<p><b>Gelatin</b> .....</p> <p><b>Slash</b> .....</p> <p>Growth, <i>uniform, best at top, best at bottom</i>.</p> <p>Line of puncture, <i>filiform, beaded, papillate, villous, arborescent</i>.</p> <p><b>Temperature</b> .....</p> <p>Liquefaction, <i>none, crateriform, infundibuliform, noniform, concave, stratiform, legumis</i> in ..... d. complete in ..... d.</p> <p>Degree of liquefaction in ..... days .....</p> <p>Method used .....</p> <p>Age .....</p> <p>Medium, <i>fluorescent, browned, unchanged</i>.</p>		<p><b>Medium (liquid)</b> .....</p> <p>Age .....</p>
<p><b>Medium (solid)</b> .....</p> <p><b>Temperature</b> .....</p> <p>Age .....</p>		<p><b>Medium</b> .....</p> <p><b>Temperature</b> .....</p> <p>Age .....</p>

Index No.\* .....

BRIEF CHARACTERIZATION

As each of the following characteristics is determined, indicate in proper marginal space by means of figure, as designated below. In case any of these characteristics are doubtful or have not been determined, indicate with the letters U, V and X, according to the following code:

U, undetermined.  
 V, variable.  
 X, doubtful.

PRIMARY CHARACTERISTICS	MICROSCOPIC FEATURES		
<p><b>MICROSCOPIC FEATURES</b></p> <p>Form: 1, streptococci; 2, diplococci; 3, micrococci; 4, sarcines; 5 rods; 6, commas; 7, spirals; 8, branched rods; 9, filamentous</p> <p>Endospores: 0, absent; 1, central; 2, excentric to terminal</p> <p>Flagella: 0, absent; 1, peritrichic; 2, polar</p> <p>Gram stain: 0, negative; 1, positive</p> <p>Biologic relationships: 1, pathogenic for man; 2, for animals but not for man; 3, for plants; 4, parasitic but not pathogenic; 5, saprophytic; 6, autotrophic</p> <p>Relation to oxygen: 1, strict aerobic; 2, facultative anaerobe; 3, strict anaerobe</p> <p>Gelatin liquefaction: 0, negative; 1, positive</p> <p>In nitrate media: 0, neither nitrite nor gas; 1, both nitrite and gas; 2, nitrite but no gas</p> <p>Chromogenesis: 1, fluorescent; 2, violet; 3, blue; 4, green; 5, yellow; 6, orange; 7, red; 8, brown; 9, pink; 0, none</p> <p>Diastatic action: 0, negative; 1, positive</p>	<p><b>MICROSCOPIC FEATURES</b></p> <p>From d-glucose: 0, no acid; 1, acid and gas; 2, acid without gas</p> <p>From lactose: 0, no acid; 1, acid and gas; 2, acid without gas</p> <p>From sucrose: 0, no acid; 1, acid and gas; 2, acid without gas</p> <p>Diameter: 1, under 0.5 μ; 2, between 0.5 μ and 1 μ; 3, over 1 μ</p> <p>Length: 1, less than 2 diameters; 2, more than 2 diameters</p> <p>Chains (4 or more cells): 0, absent; 1, present</p>		
		<p><b>MICROSCOPIC BIO-CHEMICAL REACTIONS</b></p>	<p><b>MICROSCOPIC BIO-CHEMICAL REACTIONS</b></p>
		<p><b>CARBONATE REACTIONS</b></p>	<p><b>CARBONATE REACTIONS</b></p>
<p><b>VEGETATIVE CELLS</b></p>	<p><b>VEGETATIVE CELLS</b></p>		
<p><b>SPORES</b></p>	<p><b>SPORES</b></p>		
<p><b>MAJOR SPORES</b></p>	<p><b>MAJOR SPORES</b></p>		
<p><b>CULTURAL FEATURES</b></p>	<p><b>CULTURAL FEATURES</b></p>		
<p><b>MILK</b></p>	<p><b>MILK</b></p>		
<p><b>OPTIMUM SECTIONS</b></p>	<p><b>OPTIMUM SECTIONS</b></p>		

\* Recording the "Index Number" here is optional; but its use will be found convenient if the charts are to be filed according to the salient characteristics of the organisms. The Index Number consists of the first thirteen figures from the margin (primary characteristics) copied down in the order of their occurrence in the margin, placing a dash wherever a colony name occurs in the margin. Thus the colon organism (communita type) has the Index No. 5010-V2020-1110.

Agar Colonies		SKETCHES	Gelatin Colonies		SKETCHES
Growth, <i>slow, rapid</i> . Form, <i>punctiform</i> (i. e., under 1 mm. diam.), <i>circular</i> (i. e., over 1 mm. diam.), <i>filamentous</i> , <i>irregular, raised</i> . Surface, <i>smooth, rough, concentrically ringed</i> , <i>radially ridged</i> . Elevation, <i>fuse, flat, raised, convex, pulvinate</i> , <i>umbonate</i> . Edge, <i>entire, undulate, lobate, erose, filamentous</i> , <i>curled</i> . Internal structure (low power of microscope), <i>amorphous, finely, coarsely-granular, fila-</i> <i>mentous, curled, concentric</i> .			Growth, <i>slow, rapid</i> . Form, <i>punctiform, circular, irregular, filamentous</i> Elevation, <i>flat, raised, convex, pulvinate, crater-</i> <i>form (liquifying)</i> . Edge, <i>entire, undulate, lobate, erose, filamentous</i> , <i>curled</i> . Liquefaction, <i>cup, saucer, spreading</i> . Internal structure, <i>amorphous, finely, coarsely-</i> <i>granular, filamentous, curled, concentric</i> .		
Temperature .....°C.			Temperature .....°C.		
Age .....d			Age .....d		

## PHYSIOLOGY

TEMPERATURE RELATIONS		RELATION TO OXYGEN		HYDROLYSIS OF STARCH			
Optimum temperature for growth.....°C.	Method used.....	Medium..... Temperature.....°C.		Breadth of clear zone on starch agar plates.			
Maximum temperature for growth.....°C.	Additional data.....	Aerobic growth, <i>absent, present, better than anaerobic growth</i> .		..... days:.....			
Minimum temperature for growth.....°C.		Anaerobic growth, <i>absent, occurs in presence of dextrrose, of sucrose, of lactose, of nitrate; better than aerobic growth</i> .		Additional data (e. g., by method of Meyer and Gotthell).....			
RELATION TO REACTION OF MEDIUM				FERMENTATION			
Medium used.....				Temperature.....°C.			
Optimum H-ion conc., about pH.....							
Limits of pH for growth: from.....to.....							
CHROMOGENESIS		MILK (with or without indicator)					
Nutrient gelatin.....	Reaction: 1 day..... 2 days..... 4 days..... 7 days..... 10 days.....	Temperature.....°C.		Medium.....			
Nutrient agar.....	Acid curd: 1 day..... 2 days..... 4 days..... 7 days..... 10 days.....			containing.....			
Potato.....	Rennet curd: 1 day..... 2 days..... 4 days..... 7 days..... 10 days.....			d-Glucose (dextrose),.....			
	Peptonisation: 1 day..... 2 days..... 4 days..... 7 days..... 10 days.....			Lactose.....			
	Indicator in milk (if any).....			Sucrose.....			
	Influence of indicator on growth.....						
Medium.....	Reduction of litmus begins in..... days; ends in..... days; of methylene blue in..... hours			Gas.....			
Test used.....		NITRATE REDUCTION					
Indol absent, present in..... days		Medium..... Temperature.....°C.		First appearance of acid.....			
		Gas: 1 day..... 2 days..... 4 days..... 7 days..... 10 days.....		First appearance of alkali.....			
		Medium..... Temperature.....°C.		Reaction after..... days			
		Nitrite: 1 day..... 2 days..... 4 days..... 7 days..... 10 days.....		Reaction after..... days			
		Gas: 1 day..... 2 days..... 4 days..... 7 days..... 10 days.....		Max. H-ion Conc.....			
Production of Hydrogen Sulfide							
Medium.....							
Test used.....							
H <sub>2</sub> S absent, present in..... days							

## SPECIAL TESTS (e. g., PATHOGENICITY)

Among the cultural appearances the following are of most importance:

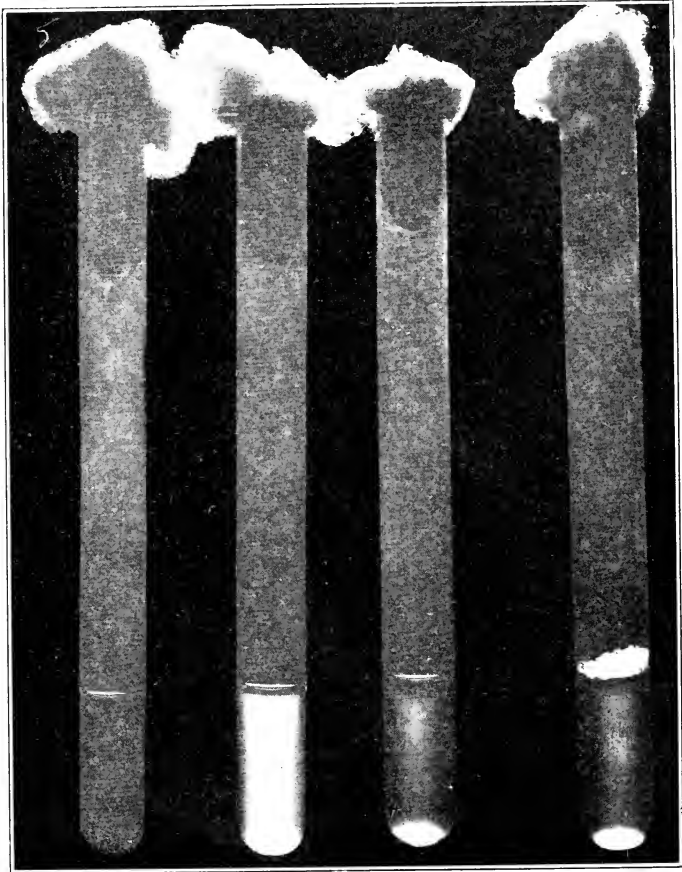

FIG. 141.—Broth cultures  $\times \frac{2}{3}$ . 1, un inoculated transparent broth; 2, broth cloudy from growth of organisms; 3, broth slightly cloudy with a deposit in bottom; 4, broth slightly cloudy with a heavy membrane at the surface.

In broth cultures the presence or absence of growth on the surface and the amount of the same. Whether the

broth is rendered cloudy or remains clear, and whether there is a deposit at the bottom or not (Fig. 141). An abundant surface growth with little or nothing below indicates a strict aërobie, while a growth or deposit at bottom and a clear or nearly clear medium above, an anaërobie. These appear-

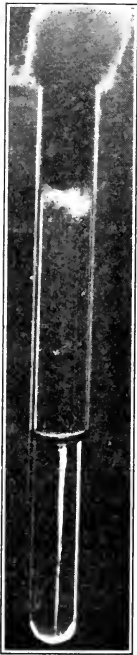

FIG. 142.—A fili-form stab or puncture culture.  $\times \frac{3}{5}$ .

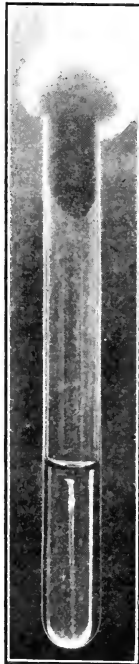

FIG. 143.—A beaded stab or puncture culture.  $\times \frac{1}{2}$ .



FIG. 144.—A villous stab or puncture culture.  $\times \frac{1}{2}$ .

ances are for the first few days only of growth. If the broth is disturbed, or after the culture stands for several days, many surface growths tend to sink to the bottom. So an actively motile organism causes in general a cloudiness, especially if the organism is a facultative anaërobie, which tends to clear up by precipitation after several days, when



the organisms lose their motility. Non-motile facultative anaerobes usually cloud the broth also, but settle out more rapidly than the motile ones.

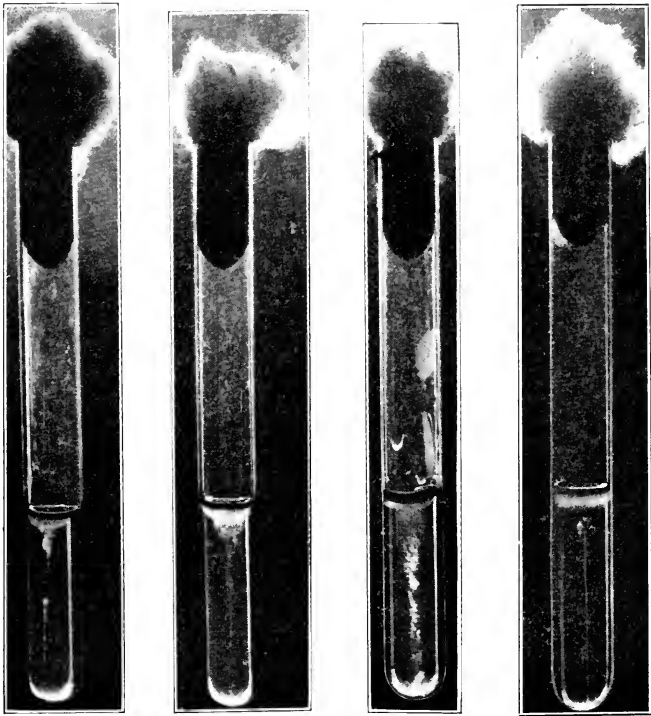

FIG. 145

FIG. 146

FIG. 147

FIG. 148

FIG. 145.—Crateriform liquefaction of gelatin.  $\times \frac{1}{2}$ .

FIG. 146.—Funnelform liquefaction of gelatin.  $\times \frac{1}{2}$ .

FIG. 147.—Saccate liquefaction of gelatin.  $\times \frac{1}{2}$ .

FIG. 148.—Stratiform liquefaction of gelatin.  $\times \frac{1}{2}$ .

In gelatin and agar punctures the oxygen relationship is shown by surface growth for aërobes, growth near the bottom of the puncture for anaerobes, and a fairly uniform growth all along the line of inoculation for facultative

anaërobes. In the case of these last organisms, a preference for more or less oxygen is indicated by the approach to the aerobic or anaërobic type of growth.

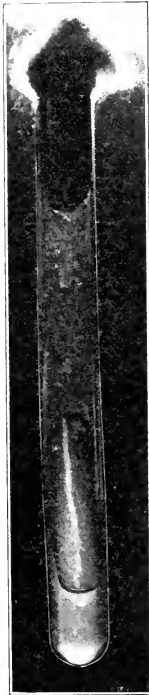

FIG. 149.—Filiform slope culture.  $\times \frac{1}{2}$ .

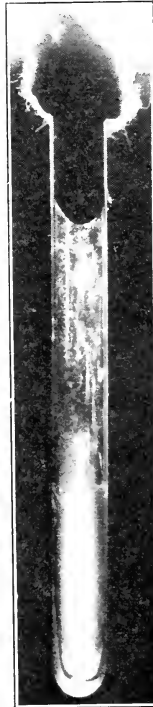

FIG. 150.—Filiform, slightly spreading, slope culture.  $\times \frac{1}{2}$ .



FIG. 151.—Beaded slope culture.  $\times \frac{1}{2}$ .

Along the line of puncture the commonest types are *filiform* (Fig. 142), which indicates a uniform growth; *beaded* (Fig. 143), or small separate colonies; *villous* (Fig. 144), delicate lateral outgrowths which do not branch; *arborescent*, tree-like growths branching laterally from the line. In agar these branchings are usually short and stubby, or technically, *papillate*.

Further, in the gelatin puncture the liquefaction which occurs is frequently characteristic. It may be *crateriform* (Fig. 145), a shallow saucer at the surface; or *funnel-shaped*



FIG. 152



FIG. 153

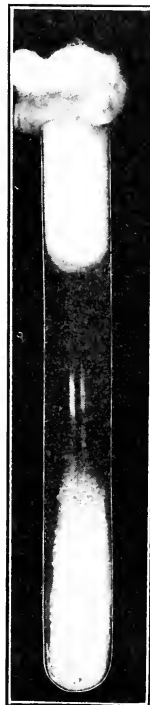

FIG. 154



FIG. 155

FIG. 152.—Effuse slope culture.  $\times \frac{1}{2}$ .  
 FIG. 153.—Rhizoid slope culture.  $\times \frac{1}{2}$ .  
 FIG. 154.—Rugose slope culture.  $\times \frac{1}{2}$ .  
 FIG. 155.—Verrucose slope culture.  $\times \frac{1}{2}$ .

(Fig. 146); or it may be of uniform width all along the puncture, *i. e.*, *saccate* (Fig. 147); or it may be *stratiform*, (Fig. 148), *i. e.*, the liquefaction extends to the sides of the tube and proceeds uniformly downward.

On agar, potato and blood serum slope tubes the amount of growth, its form and elevation, the character of the surface and the consistency should be carefully noted, and in



FIG. 156.—Punctiform colonies on a plate.  $\times \frac{1}{2}$ .



FIG. 157.—A rhizoid colony on a plate. Natural size.

some few cases the character of the edge. Figs. 149 to 155 show some of the commoner types.

On agar and gelatin plates made so that the colonies are well isolated, the form of the latter, the rate of their growth, the character of the edge and of the surface, the elevation



FIG. 158.—Amœboid colonies on a plate.  $\times \frac{1}{2}$ .



FIG. 159.—Large effuse colony on a plate. The edge is lacerated. Incidentally the colony shows the rate of growth for six successive days.  $\times \frac{1}{2}$ .



FIG. 160.—Colony with edge entire as seen under the low-power objective.  $\times 100$ .

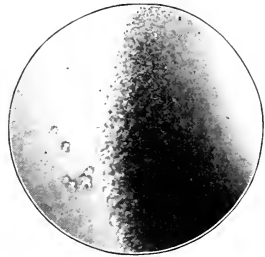

FIG. 161.—Colony with edge coarsely granular as seen under the low-power objective.  $\times 100$ .

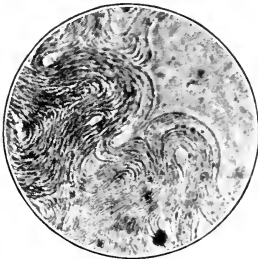

FIG. 162.—Colony with edge curled, as seen under the low-power objective.  $\times 100$ .

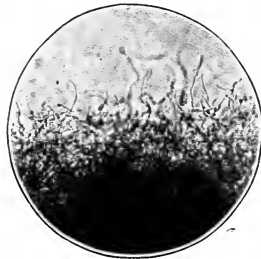

FIG. 163.—Colony with edge rhizoid, as seen under the low-power objective.  $\times 100$ .



FIG. 164.—A small deep rhizoid colony as seen under the low-power objective.  $\times 100$ .

and the internal structure as determined by a low-power lens are often of almost diagnostic value. Also in the case of the gelatin plates, the character of the liquefaction is important. Figs. 156 to 164 show some of the commoner characteristics to be noted.

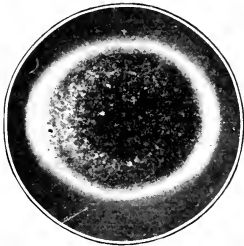

FIG. 165.—A small mold colony, natural size, as viewed by transmitted light.



FIG. 166.—The same colony as viewed by reflected light.



FIG. 167.—A portion of the thin edge of the same colony as seen with the low-power objective.  $\times 100$ .

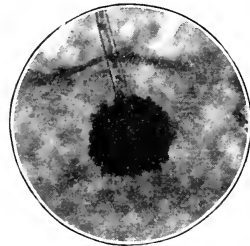

FIG. 168.—A single fruiting body (sporangium) from the same colony as seen under the low-power objective.  $\times 100$ .

Colonies of mold frequently appear on plates. These are readily differentiated from bacterial colonies after a little experience. With the naked eye usually the fine radiations of the edge of the colony are apparent. The surface appears duller and by reflected light more or less "fuzzy." With the low-power objective the relatively large, branching threads of the mold (mycelia) show distinctly. Also the large fruiting bodies (sporangia) are easily distinguished. Figs. 165 to 168 illustrate a common black mold (*Rhizopus nigricans*).

## CHAPTER XXI.

### ANIMAL INOCULATION.

ANIMAL inoculation has been referred to (1) as a method of assisting in the preparation of pure cultures of pathogenic organisms; (2) as a means of testing the poisonous properties of substances produced in bacterial cultures; (3) in order to test the ability of an organism to cause a disease; (4) for the production of various antibodies; it may be added (5) that some bacteria produce in the smaller experimental animals lesions which do not occur in animals naturally infected, but which nevertheless are characteristic for the given organism. The best illustration is the testicular reaction of young male guinea-pigs to intraperitoneal injections of glanders bacilli. Experimental animals are also inoculated (6) to test the potency of various bacterial and other biological products, as toxins, antitoxins, etc.

Guinea-pigs are the most widely used experimental animals because they are easily kept and are susceptible to so many diseases on artificial inoculation. Rabbits are used very largely also, as are white mice. For special purposes white rats, pigeons, goats and swine are necessary. For commercial products, horses (antitoxins) and cattle (small-pox vaccine) are employed. In the study of many human diseases the higher monkeys and even the anthropoid apes are necessary, since none of the lower animals are susceptible.

The commonest method of animal inoculation is undoubtedly the *subcutaneous*. This is accomplished most readily with the hypodermic needle. The skin at the point selected (usually in guinea-pigs the lateral posterior half of the abdominal surface, in mice the back near the root of the tail) is pinched up to avoid entering the muscles and the needle quickly inserted. Clipping the hairs and washing with an antiseptic solution should precede the inoculation as routine practice. Frequently a small "skin pocket" is all that is needed. The hair is clipped off, the skin pinched up with small forceps and a slight snip with sharp scissors is made. The material may be inserted into this pocket with a heavy platinum needle. *Cutaneous* inoculation is



made by shaving the skin and rubbing the material onto the shaved surface or scratching with a scalpel or special scarifier, but without drawing blood, and then rubbing in the material to be inoculated. *Intracutaneous* inoculation is performed with a finer needle than the ordinary hypodermic needle and is made just *into* the true skin and not *through* or *under* it.

*Subepithelial* injections, just between the true skin and the epidermis, are to be preferred to intracutaneous; this is the procedure for the "Schick test" in diphtheria and is being introduced for smallpox vaccination.

*Intravenous* injections are made with larger animals. In rabbits the posterior external auricular is a convenient vein. In larger animals the external jugular is used.

*Intraperitoneal*, *-thoracic*, *-cardiac*, *-ocular*, *-muscular* injections, and injections into the parenchyma of internal organs are accomplished with the hypodermic needle. In the case of the first two, injury to contained organs should be carefully avoided. Intracardiac injection, or aspiration of the heart to secure blood, requires considerable practice to be successful without causing the death of the animal at once through internal hemorrhage. In *subdural* injections into the cranial cavity it is necessary to trephine the skull first, while such injections into the spinal canal may be accomplished between the vertebræ with needles longer and stronger than the usual hypodermic needle. Occasionally animals are caused to *inhale* the organisms, or are *fed* cultures mixed with the feed.

### SECURING AND TRANSPORTING MATERIAL FROM ANIMALS FOR BACTERIOLOGICAL EXAMINATION.

If the site of the lesion is readily accessible from the exterior, material from the *living animal* should be collected with sterile instruments and kept in sterile utensils until the necessary tests can be made. Testing should be done on material as soon after collection as possible, in all cases, to avoid the effects of "decomposition" bacteria.

If the blood is to be investigated it may be aspirated from a peripheral vein with a sterile hypodermic syringe of appropriate size or allowed to flow through a sterile cannula into

sterile receptacles. The site of the puncture should be shaved and disinfected before the instrument is introduced.

Discharges of whatever kind should likewise be collected in sterile receptacles and examined as soon as may be.

If internal organs are to be examined it is best to kill a moribund animal than to wait for death, since after death, and in severe infections, even sometimes before, the tissues are rapidly invaded by saprophytic bacteria from the alimentary and respiratory tracts which complicate greatly the isolation of the specific organism. Hence the search for specific bacteria in carcasses or organs several hours after death is frequently negative. Animal inoculation with such material is very often followed by sepsis or septicemia in a few hours, so that the specific organism has no opportunity to manifest itself.

In securing material for cultures from internal organs it is a good plan to burn the surface of the organ with a gas or alcohol flame, or to sear it with a hot instrument to kill surface organisms, then make the incision or puncture through the burned area and secure material from the interior of the organ. Such punctures made with a stiff platinum needle frequently give pure cultures of the organism sought. Slides may be made from such material and culture media inoculated at once.

Since a bacteriological diagnosis depends most commonly on growing the organisms, it is evident that material sent for examination must *never be treated with an antiseptic or preservative*. If decomposition is to be feared the only safe procedure is to *pack the material in ice* and forward in this way.

*Tuberculous material from the parenchyma* of internal organs may be forwarded in a preservative (not *formalin*, since this makes it very difficult to stain the bacteria), as in *this special case* a very positive diagnosis may be made by staining alone. Even here it is better to *pack in ice* in order that the diagnosis by staining may be confirmed by inoculating the living organisms into guinea-pigs.

In the case of material *from a rabid animal* and many protozoal diseases the rule against preservatives is not absolute, since staining is a reliable diagnostic means. Even in these cases it is often desirable to inoculate animals, hence, as before stated, it is best to make it a uniform practice to *pack material for examination in ice and use no preservatives*.

PART IV.

GENERAL PATHOGENIC BACTERI-  
OLOGY.

CHAPTER XXII.

INTRODUCTION.

PATHOGENIC bacteriology treats of the unicellular microorganisms which are responsible for disease conditions, *i. e.*, pathological changes in other organisms. Hence not only are bacteria considered, but also other low vegetable forms, as yeasts and molds, likewise protozoa in so far as they may be pathogenic. For this reason the term pathogenic "Microbiology" has been introduced to include all these organisms. It is largely for the reason that the methods devised for the study of bacteria have been applied to the investigation of other microorganisms that the term "bacteriology" was extended to cover the entire field. The general discussion in this chapter is intended to include, therefore, microorganisms of whatever kind pathogenic to animals.

The term pathogenic as applied to an organism must be understood in a purely *relative* sense, since there is no single organism that can cause disease in all of a certain class, but each is limited to a more or less narrow range. Some form of tuberculosis attacks nearly all vertebrates, but no other classes of animals and no plants. Lockjaw or tetanus attacks most mammals, but not any other vertebrates naturally. Typhoid fever affects human beings; hog cholera,

swine, etc. This point is more fully discussed in Chapter XXIII, but cannot be too greatly insisted upon.

“The greatest enemy to mankind is man.”

Exceptions to this statement do occur and are important, and must be considered in efforts to protect completely human beings from disease (tuberculosis from cattle, glanders from horses, poisoning from spoiled canned goods, anthrax from hair, hides, wool, of animals dead of the disease), but the most common human diseases are derived from other human beings directly or indirectly.

Diseases which are due to unicellular pathogenic microorganisms are called *infectious* diseases, while if such diseases are transmitted under natural conditions from organism to organism they are spoken of as *contagious* diseases. Most infectious diseases are contagious, but not all. Tetanus is a good illustration of a non-contagious infectious disease. There are very few such diseases.

When a unicellular microorganism gains entrance into the body and brings about any pathological changes there the result is an *infection*. Undoubtedly many pathogenic organisms get into the body but never manifest their presence by causing disease conditions, hence do not cause an infection. It is the pathological conditions which result that constitute the infection and not the mere *invasion*.

The time that elapses between the entrance of the organism and the appearance of symptoms is called the *period of incubation* and varies greatly in different diseases.

The term *infestation* is used to denote pathological conditions due to *multicellular* parasites. Thus an animal is *infested* (not infected) with tapeworms, roundworms, lice, mites, etc. Many of these conditions, probably all, are contagious, *i. e.*, transmissible naturally from animal to animal. The word *contagious* has been used in a variety of ways to mean *communicated by direct contact*, communicated by a living something (*contagium*) that might be carried to a distance and finally *communicable* in any manner, transmissible. The agency of transmission may be very

roundabout—as through a *special tick* in Texas fever, a *mosquito* in malaria, etc.—or by direct personal contact, as generally in venereal diseases. After all, though exactness is necessary, it is better to learn all possible about the *means of transmission of diseases* than quibble as to the terms to be used.

An infectious disease may be *acute* or *chronic*. An acute infection is one which runs for a relatively short time and is “self-limited,” so-called, *i. e.*, the organisms cease to manifest their presence after a time. In some acute infections the time is very short—German measles usually runs five or six days. Typhoid fever may continue eight to ten weeks, sometimes longer, yet it is an acute infectious disease. It is not so much the time as the fact of *self-limitation* that characterizes acute infections.

In chronic infections there is little or no evidence of limitation of the progress of the disease which may continue for years. Tuberculosis is usually chronic. Leprosy in man is practically always so. Glanders in horses is most commonly chronic; in mules and in man it is more apt to be acute.

Many infections begin acutely and later change to the chronic type. Syphilis in man is a good illustration.

The differences between acute and chronic infections are partly due to the nature of the organism, partly to the number of organisms introduced and the point of their introduction and partly to the resistance of the animal infected.

An infectious disease is said to be *specific* when one kind of organism is responsible for its manifestations—as diphtheria due to the *Corynebacterium diphtheriæ*, lockjaw due to *Clostridium tetani*, Texas fever due to the *Piroplasma bigeminum*, etc. It is *non-specific* when it may be due to a variety of organisms, as *enteritis* (generally), *bronchopneumonia*, *wound infections*.

Henle, as early as 1840, stated certain principles that must be established before a given organism can be accepted as the cause of a specific disease. These were afterward restated by Koch and have come to be known as “Koch’s postulates.” They may be stated as follows:

1. The given organism must be found in all cases of the disease in question.

2. No other organism must be found in all cases.
3. The organism must, when obtained in pure culture, reproduce the disease in susceptible animals.
4. It must be recovered from such animals in pure culture and this culture likewise reproduce the disease.

These postulates have not been fully met with reference to any disease, but the principles embodied have been applied as far as possible in all those infections which we recognize as specific and whose causative agent is accepted. In many diseases recognized as infectious and contagious no organism has been found which is regarded as the specific cause. In some of these the organism appears to be too small to be seen with the highest powers of the microscope, hence they are called "*ultramicroscopic*" organisms. Because these agents pass through the finest bacterial filters they are also frequently called "*filterable*." The term "*virus*" or "*filterable virus*" is likewise applied to these "*ultramicroscopic*" and "*filterable*" agents.

The term *primary infection* is sometimes applied to the first manifestation of a disease, either specific or non-specific, while *secondary* refers to later developments. For example, a *secondary* general infection may follow a *primary* wound infection, or *primary* lung tuberculosis be followed by *secondary* generalized tuberculosis, or *primary* typhoid fever by a *secondary typhoid pneumonia*. The terms *primary* and *secondary* are also used where the body is invaded by one kind of an organism and later on by another kind; thus a *primary* measles may be followed by *secondary* infection of the middle ear, or a *primary* influenza may be followed by a *secondary* pneumonia, or a *primary* scarlet fever by a *secondary* nephritis (inflammation of the kidney). Where several organisms seem to be associated simultaneously in causing the condition then the term *mixed infection* is used—in severe diphtheria, streptococci are commonly associated with the *Corynebacterium diphtheriæ*. In many cases of hog cholera, mixed infections in the lungs and in the intestines are common. Wound infections are usually *mixed*. *Auto-infection* refers to those conditions in which an organism commonly present in or on the body in a latent or harm-

less condition gives rise to an infectious process. If the *Escherichia coli* normal to the intestine escapes into the peritoneal cavity, or passes into the bladder, a severe peritonitis or cystitis, respectively, is apt to result. "Boils" and "pimples" are frequently autoinfections. Such infections are also spoken of as *endogenous* to distinguish them from those due to the entrance of organisms from without—*exogenous* infections. *Relapses* are usually instances of autoinfection.

Those types of *secondary infection* where the infecting agent is transferred from one disease focus to another or several other points and sets up the infection there are sometimes called *metastases*. Such are the transfer of tubercle bacilli from lung to intestine, spleen, etc., the formation of abscesses in internal organs following a primary surface abscess, the appearance of glanders nodules throughout various organs following pulmonary glanders, etc.

**Focal Infection.**—A focal infection is an infection usually small and circumscribed from which *toxins*, sometimes organisms, are absorbed and carried to other parts of the body where they give rise to symptoms. The focal infection itself may show slight symptoms or none at all. The effects in other organs are frequently not associated with the "focus." The commonest "foci" are at the roots of the teeth, the tonsils, sinuses about the head, chronic appendicitis, prostate, Fallopian tubes. The organism causing focal infections is most frequently the streptococcus. Neuritis, "rheumatism," rheumatic and muscular pains, headaches, "dyspepsia" are frequently associated with focal infections.

The characteristic of a pathogenic microörganism which indicates its ability to cause disease is called its *virulence*. If slightly virulent the effect is slight; if highly virulent the effect is severe and may be fatal.

On the other hand the characteristic of the host which indicates its capacity for infection is called *susceptibility*. If slightly susceptible, infection is slight; if highly susceptible the infection is severe.

Evidently the degree of infection is dependent in large measure on the relation between the *virulence* of the invad-

ing organism and the *susceptibility* of the host. High virulence and great susceptibility mean a severe infection; low virulence and little susceptibility a slight infection; while high virulence and little susceptibility or low virulence and great susceptibility might mean a moderate infection varying in either direction. Other factors influencing the degree of infection are the number of organisms introduced, the point where they are introduced and various conditions. These will be discussed in another connection (Chapter XXV).

The study of pathogenic bacteriology includes the thorough study of the individual organisms according to the methods already given (Chapters XVIII–XXI) as an aid to diagnosis and subsequent treatment, bacteriological or other, in a given disease. Of far greater importance than the *treatment*, which in most infectious diseases is not specific, is the *prevention* and *ultimate eradication* of all infectious diseases. To accomplish these objects involves further a study of the *conditions under which pathogenic organisms exist outside the body, the paths of entrance into and elimination from the body* and those *agencies within the body itself* which make it *less susceptible to infection or overcome the infective agent after its introduction*. That condition of the body itself which prevents any manifestation of a virulent pathogenic organism after it has been once introduced is spoken of as *immunity* in the modern sense. Immunity is thus the opposite of susceptibility and may exist in varying degrees.

That scientists are and have been for some years in possession of sufficient knowledge to permit of the prevention and eradication of most, if not all, of our infectious diseases can scarcely be questioned. The practical application of this knowledge presents many difficulties, the chief of which is the absence of a public sufficiently enlightened to permit the expenditure of the necessary funds. Time and educative effort alone can surmount this difficulty. It will probably be years yet, but it will certainly be accomplished.



## CHAPTER XXIII.

### PATHOGENIC BACTERIA OUTSIDE THE BODY.

PATHOGENIC bacteria may exist outside the body of the host under a variety of conditions as follows:

I. In or on inanimate objects or material.

(a) As true saprophytes.

(b) As facultative saprophytes.

(c) Though obligate parasites they exist in a latent state.

II. In or on other animals or products from them:

A. Susceptible to the disease.

(a) Sick themselves.

(As far as human beings are concerned these are mainly:

1. Other human beings for most diseases.

2. Rats for plague.

3. Dogs for rabies.

4. Horses for glanders.

5. Cattle, swine, parrots for tuberculosis).

(b) Recovered from illness.

(c) Never sick but "carriers."

B. Not susceptible.

(d) Accidental carriers.

(e) Serving as necessary intermediate hosts for certain stages of the parasite—this applies to *protozoal* diseases only, as yet.

I. (a) The bacilli of tetanus, malignant edema and the organisms of "gas gangrene" are widely distributed. There is no evidence that their entrance into the body is at all necessary for the continuation of their life processes or that one case of either of these diseases ever has any connection with any other case; they are true saprophytes. Mani-

festly it would be futile to attempt to prevent or eradicate such diseases by attacking the organism in its natural habitat. *Clostridium botulinum*, which causes a type of food poisoning in man, does not even multiply in the body, but the disease symptoms are due to a soluble toxin which is produced during its growth outside the body.

(b) Organisms like the bacterium of anthrax and the bacillus of black-leg from their local occurrence seem to be distributed from animals infected, though capable of a saprophytic existence outside the body for years. These can no more be attacked during their saprophytic existence than those just mentioned. Doubtless in warm seasons of the year and in the tropics other organisms pathogenic to animals may live and multiply in water or in damp soil where conditions are favorable, just as the cholera organism in India and occasionally the typhoid bacillus in temperate climates do.

(c) Most pathogenic organisms, however, when they are thrown off from the bodies of animals, remain quiescent, do not multiply, in fact always tend to die out from lack of all that is implied in a "favorable environment," food, moisture, temperature, light, etc. Disinfection is sometimes effective in this class of diseases in preventing new cases.

II. A. (a) The most common infectious diseases of animals are transmitted more or less directly from other animals of the same species. Human beings get nearly all their diseases from other human beings who are sick; horses, from other horses; cattle, from other cattle; swine, from swine, etc. Occasionally transmission from one species to another occurs. Tuberculosis of swine most frequently results from feeding them milk of tuberculous cattle or from their eating the droppings of such cattle. Swine may also contract avian (bird) tuberculosis from chickens. Human beings occasionally contract anthrax from wool, hair and hides of animals dead of the disease or from postmortems on such animals; glanders from horses; tuberculosis (in children) from tuberculous milk; bubonic plague from rats; tularemia from rabbits and other rodents; rabies practically always from the bites of dogs and other rabid

animals, etc. The mode of limiting this class of diseases is evidently to isolate the sick, disinfect their discharges and their *immediate* surroundings, sterilize such products as must be handled or used, kill lower animals that are dangerous, and disinfect, bury properly or destroy their carcasses.

Classes of the sick that are especially dangerous for the spread of disease are the mild cases and the undetected cases. These individuals do not come under observation and hence not under control.

(b) This class of carriers offers a difficult problem in the prevention of infectious diseases, since they may continue to give off the organisms indefinitely and thus infect others. Typhoid carriers have been known to do so for fifty-five years. Cholera, diphtheria, meningitis and other carriers are well known in human practice. Carriers among animals have not been so frequently demonstrated, but there is every reason for thinking that hog cholera, distemper, roup, influenza and other carriers are common. Carriers furnish the explanation for many of the so-called "spontaneous" outbreaks of disease among men and animals.

It is the general rule that those who are sick cease to carry the organisms on recovery, and it is the occasional ones who do not that are the exceptions. In those diseases in which the organism is known it can be determined by examination of the patient or his discharges how long he continues to give off the causative agent. In those in which the cause is unknown (in human beings, the commonest and most easily transmitted diseases, scarlet fever, measles, German measles, mumps, chicken-pox, small-pox, influenza) no such check is possible. It is not known how long such individuals remain carriers. Hence isolation and quarantine of such convalescents are based partly on experience and partly on theory. It is highly probable that in the diseases just mentioned transmission occurs in the *early stages only*, except in small-pox and chicken-pox, where the organism seems to be in the pustules and transmission by means of material from these is possible, though only by direct contact with it.

The fact that such individuals are *known to have had the disease* is a guide for control. The methods to be used are essentially the same as for the sick, (*a*) though obviously such human carriers are much more difficult to deal with since they are well.

(*c*) Another class of carriers is those who have never had the disease. Such individuals are common and are very dangerous sources of infection. Many of them have *associated with the sick or with convalescents*, and these should always be suspected of harboring the organisms. Their control differs in no way from that of class (*b*). Unfortunately a history of such association is too often not available. Modern transportation and modern social habits are largely responsible for the nearly universal distribution of this type of carrier. Their detection is probably the largest single problem in the prevention of infectious diseases. A partial solution would be universal bacteriological examination. In our present stage of progress this is impossible and would not detect carriers of diseases of unknown cause.

The various classes of carriers just discussed are in a large part responsible for the continued presence of the commoner diseases throughout the country. The difficulties in control have been mentioned. A complete solution of the problem is not yet obtained. The army experience of the past few years in the control of infectious diseases shows what may be done.

There is another class of carriers which might be called the "universal carrier," *i. e.*, there are certain organisms which seem to be constantly or almost constantly present in or on the human body. These are *staphylococci*, *streptococci* and *pneumococci*, all *Gram-positive* organisms. They are ordinarily harmless parasites, but on occasion may give rise to serious, even fatal, infection. Infected wounds, pimples, boils, "common colds," most "sore throats," bronchitis, pneumonia are pathological conditions that come in this class. Such infections are usually autogenous. There is a constant interchange of these organisms among individuals closely associated, so that all of a group usually harbor the same type though no one individual can be

called *the carrier*. Whenever, for any reason, the resistance of an individual (see Chapters XXV *et seq.*) is lowered either locally or generally some of these organisms are liable to gain a foothold and cause infection. It sometimes happens that a strain of dangerous organisms may be developed in an individual in this way which is passed around to others with its virulence increased and thus causes an epidemic. Or, since all of the group are living under the same conditions the resistance of all or many of them may be lowered from the same general cause and an epidemic result from the organism common to all (pneumonia after measles, scarlet fever and influenza in camps). Protection of the individual is chiefly a personal question, *i. e.*, by keeping up the "normal healthy tone" in all possible ways. The use of protective vaccines (Chapter XXX) appears to be advisable in such instances (colds, pneumonia after measles and influenza, inflammation of throat and middle ear following scarlet fever and measles). Results obtained in this country during the recent influenza epidemic have been conflicting, but, on the whole appear to show that preventive vaccination against *pneumonia liable to follow* should be practised.

It would seem that among groups of individuals where infection may be expected the proper procedure would be to prepare autogenous vaccines (Chapter XXX) from members of the group and vaccinate all with the object of protecting them.

II. B. (*d*) In this class come the "accidental carriers" like flies, fleas, lice, bed-bugs, ticks and other biting and blood-sucking insects, vultures, buzzards, foxes, rats and carrion-eating animals generally; pet animals in the household, etc. Here the animals are not susceptible to the given disease but become contaminated with the organisms and then through defilement of the food or drink or contact with individuals or with utensils pass the organisms on to the susceptible. Some biting and blood-sucking insects transmit the organisms through biting infected and non-infected animals successively. The spirilloses and trypanosomiases seem to be transmitted in this way, though there is evidence

accumulating which may place these diseases in the next class. Anthrax is considered in some instances to be transmitted by flies and by vultures in the southern United States. Transmission of typhoid, dysentery, cholera and other diseases by flies is well established in man. Why not hog cholera from farm to farm by flies, English sparrows, pigeons feeding or by turkey buzzards? Though this would not be easy to prove, it seems reasonable.

Preventing contact of such animals with the discharges or with the carcasses of those dead of the disease, destruction of insect carriers, screening and prevention of fly breeding are obvious protective measures.

(e) In this class come certain diseases for which particular insects are necessary for the parasite in question, so that certain stages in its life history may be passed therein. The surest means for eradicating such diseases is the destruction of the insects concerned. Up to the present no bacterial disease is known in which this condition exists, unless Rocky Mountain spotted fever and typhus fever shall prove to be due to bacteria. Such diseases are all due to protozoa. Among them are Texas fever due to *Piroplasma bigeminum* in this country, which has been eradicated in entire districts by destruction of the cattle tick (*Margaropus annulatus*).

Piroplasmoses in South Africa among cattle and horses and in other countries are transmitted in similar ways. Probably many of the diseases due to spirochetes and trypanosomes are likewise transmitted by *necessary* insect intermediaries. In human medicine the eradication of yellow fever from Panama and Cuba is due to successful warfare against a certain mosquito (*Aedes*). So the freeing of large areas in different parts of the world from *malaria* follows the destruction of the mosquitoes. The prevention of typhus fever and of trench fever by "delousing" methods is familiar from recent army experience though for typhus this method had been practised in Russia for more than ten years to the author's personal knowledge. The campaign against disease in animals and man from insect sources must be considered as still in its infancy. The full utilization of tropical lands depends largely on the solution of this problem.

## CHAPTER XXIV.

### PATHS OF ENTRANCE OF PATHOGENIC ORGANISMS, OR CHANNELS OF INFECTION.

**A. The Skin.**—If the skin is healthy there is no opportunity for bacteria to penetrate it. It is protected not only by the stratified epithelium, but also in various animals by coats of hair, wool, feathers, etc. The secretion pressure of the healthy sweat and oil glands acts as an effective bar even to motile bacteria. Nevertheless a very slight injury only is sufficient to give normal surface parasites and other pathogenics, accidentally or purposely brought in contact with it, an opportunity for more rapid growth and even entrance for general infection. Certain diseases due to higher fungi are characteristically “skin diseases” and rarely become general—various forms of favus, trichophyton infections, etc. A few disease organisms, tetanus, malignant edema, usually get in through the skin; others, black-leg and anthrax, quite commonly; and those diseases transmitted by biting and blood-sucking insects, piroplasmoses, trypanosomiases, spirilloses, scarcely in any other way. Defective secretion in the skin glands from other causes may permit lodgement and growth of bacteria in them or in the hair follicles. “Pimples” and boils in man and local abscesses occasionally in animals are illustrations. Sharp-edged and freely bleeding wounds are less liable to be infected than contusions, ragged wounds, burns, etc. The flowing blood washes out the wound and the clotting seals it, while there is less material to be repaired by the leukocytes and they are free to care for invading organisms (phagocytosis). Pathogenic organisms, especially pus cocci, frequently gain lodgement in the *milk glands* and cause local (mastitis) or general infection.

**B. Mucosæ directly continuous with the skin and lined with stratified epithelium** are commonly well protected thereby and by the secretions.

(a) The external auditory meatus is rarely the seat even of local infection. The tympanic cavity is normally sterile, though it may become infected by extension through the Eustachian tube from the pharynx (*otitis media*).

(b) The conjunctiva is frequently the seat of localized, very rarely the point of entrance for a generalized infection, except after severe injury. Those diseases whose path of entrance is generally assumed to be the respiratory tract (see "Lungs" below) might also be admitted through the eye. Material containing such organisms might get on the conjunctiva and be washed down through the lacrimal canal into the nose. Experiment has shown that bacteria may pass in this way in a few minutes. In case masks are worn to avoid infection from patients suffering with these diseases, the eyes should therefore be protected as well as the nose and mouth.

(c) The nasal cavity on account of its anatomical structure retains pathogenic organisms which give rise to local infections more frequently than other mucosæ of its character. These may extend from here to middle ear, neighboring sinuses, or along the lymph spaces of the olfactory nerve into the cranial cavity (meningitis). Acute coryza ("colds" in man) is characteristic. Glanders, occasionally, is primary in the nose, as is probably roup in chickens, leprosy in man. The meningococcus and the virus of poliomyelitis pass from the nose into the cranial cavity without local lesions in the former.

(d) The mouth cavity is ordinarily protected by its epithelium and secretions, though the injured mucosa is a common source of *actinomycosis* infection as well as thrush. In foot-and-mouth disease no visible lesion seems necessary to permit the localization of the unknown infective agent.

(e) The tonsils afford a ready point of entrance for ever-present *staphylococci* and *streptococci* whenever occasion offers (follicular tonsillitis, "quinsy"), and articular rheumatism is not an uncommon sequel. The diphtheria bacillus charac-



teristically seeks these structures for its development. Tubercle and anthrax organisms occasionally enter here.

(f) The pharynx is the seat of localized infection, as in *staphylococcal*, *streptococcal* and diphtherial "sore throat" in human beings; but both it and the esophagus are rarely infected in animals except as the result of injury.

(g) The external genitalia are the usual points of entrance for the venereal organisms in man (gonococcus, *Treponema pallidum* and Ducrey's bacillus). The bacillus of contagious abortion and probably the trypanosome of dourine are commonly introduced through these channels in animals.

**C. Lungs.**—The varied types of pneumonia due to many different organisms (tubercle, glanders, influenza, plague bacilli, pneumococcus, streptococcus, staphylococcus and many others) show how frequently these organs are the seat of a localized infection, which may or may not be general. Whether the lungs are the actual point of entrance in these cases is a question which is much discussed at the present time, particularly with reference to tuberculosis. The mucous secretion of the respiratory tract tends to catch incoming bacteria and other small particles and the ciliary movement along bronchial tubes and trachea tends to carry such material out. "Foreign body pneumonia" shows clinically, and many observers have shown experimentally that microorganisms may reach the alveoli even though the exchange of air between them and the bronchioles and larger bronchi takes place ordinarily only by diffusion. The presence of carbon particles in the walls of the alveoli in older animals and human beings and in those that breathe dusty air for long periods indicates strongly, though it does not prove absolutely, that these came in with inspired air. On the other hand, experiment has shown that tubercle bacilli introduced into the intestine may appear in the lungs and cause disease there and not in the intestine. It is probably safe to assume that in those diseases which are transmitted most readily through close association, though not necessarily actual contact, the commonest path is through the respiratory tract, which may or may not show lesions (small-pox, scarlet fever, measles, chicken-pox, whooping-cough,

pneumonic plague in man, lobar and bronchopneumonias and influenza in man and animals, some cases of glanders and tuberculosis). On the other hand, the fact that the *Eberthella typhi* and *Escherichia coli* may cause pneumonia when they evidently have reached the lung from the intestinal tract, and the experimental evidence of lung tuberculosis above mentioned show that this route cannot be excluded in inflammations of the lung.

**D. Alimentary Tract.**—The alimentary tract affords the ordinary path of entrance for the causal microbes of many of the diseases of animals and man, since they are carried into the body most commonly and most abundantly in the food and drink.

(a) The stomach is rarely the seat of local infection, even in ruminants, except as the result of trauma. The character of the epithelium in the rumen, reticulum and omasum in ruminants, the hydrochloric acid in the abomasum and in the stomachs of animals generally are usually sufficient protection. Occasionally anthrax "pustules" develop in the gastric mucosa. (The author saw nine such pustules in a case of anthrax in a man.)

(b) The intestines are frequently the seat of localized infections, as various "choleras" and "dysenteries" in men and many animals, anthrax, tuberculosis, Johne's disease. Here doubtless enter the organisms causing "hemorrhagic septicemias" in many classes of animals and numerous others. These various organisms must have passed through the stomach, and the question at once arises, Why did the HCl not destroy them? It must be remembered that the acid is present only during stomach digestion, and that liquids taken on an "empty stomach" pass through rapidly and any organisms present are not subjected to the action of the acid. Also spores generally resist the acid. Other organisms may pass through the stomach within masses of undigested food. The fact that digestion is going on in the stomach of ruminants practically all the time may explain the relative freedom of *adult* animals of this class from "choleras" and "dysenteries."

### MECHANISM OF ENTRANCE OF ORGANISMS.

In the preceding chapters statements have been made that "bacteria enter" at various places or they "pass through" different mucous membranes, skin, etc. Strictly speaking such statements are incorrect—bacteria do not "enter" or "pass through" of themselves. It is true that some of the intestinal organisms are motile, but most of the bacteria which are pathogenic are non-motile. Even the motile ones cannot make their way against fluids secreted or excreted on free surfaces. Bacteria cannot pass by diffusion through membranes, since they are finite particles and not in solution.

In the case of penetrating wounds bacteria may be carried mechanically into the tissues, but this is exceptional in most infections. Also after gaining lodgement they may gradually grow through by destroying tissue as they grow, but this is a minor factor. Evidently, there must be some mechanism by which they *are carried* through. The known mechanisms for this in the body are amœboid cells, especially the phagocytes. It is most probable that these are the chief agents in getting bacteria into the tissues through various free surfaces. The phagocytes engulf bacteria, carry them into the tissues and either destroy them, are destroyed by them or may disgorge or excrete them free in the tissues or in the blood.

### DISSEMINATION OF ORGANISMS.

Dissemination of organisms within the tissues occurs either through the lymph channels or the bloodvessels, or both. If through the lymph vessels only it is usually much more restricted in extent, or much more slowly disseminated, while blood dissemination is characterized by the number of organs involved simultaneously.

### PATHS OF ELIMINATION OF PATHOGENIC MICRO-ORGANISMS.

I. Directly from the point of injury. This is true in infected wounds open to the surface, skin glanders (farcy),

black-leg, surface anthrax, exanthemata in man and animals (scarlet fever (?), measles (?), small-pox; hog erysipelas, foot-and-mouth disease): Also in case of disease of mucous membranes continuous with the skin—from nasal discharges (glanders), saliva (foot-and-mouth disease), material coughed or sneezed out (tuberculosis, influenza, pneumonias), urethral and vaginal discharges (gonorrhoea and syphilis in man, contagious abortion and dourine in animals), intestinal discharges (typhoid fever, "choleras," "dysenteries," anthrax, tuberculosis, Johne's disease). Material from nose, mouth and lungs may be swallowed and the organisms passed out through the intestines.

II. Indirectly through the secretions and the excretions where the internal organs are involved. The *saliva* of rabid animals contains the ultramicroscopic virus of rabies (the sympathetic ganglia within the salivary glands, and pancreas also, are affected in this disease as well as the cells of the central nervous system). The *gall-bladder* in man is known to harbor colon and typhoid bacilli, as that of hog cholera hogs does the virus of this disease. It may harbor analogous organisms in other animals, though such knowledge is scanty. The *kidneys* have been shown experimentally to excrete certain organisms introduced into the circulation within a few minutes (staphylococci, colon and typhoid bacilli, anthrax). Typhoid bacilli occur in the urine of typhoid-fever patients in about 25 per cent of all cases and the urine of hogs with hog cholera is highly virulent. Most observers are of the opinion, however, that under natural conditions the kidneys do not excrete bacteria unless they themselves are infected.

The *milk* both of tuberculous cattle and tuberculous women has been shown to contain tubercle bacilli *even when the mammary glands are not involved*. Doubtless such bacteria are carried through the walls of the secreting tubules or of the smaller ducts by phagocytes and are then set free in the milk.

**SPECIFICITY OF LOCATION OF INFECTIVE ORGANISMS.**

It is readily apparent that certain disease organisms tend to locate themselves in definite regions and the question arises, Is this due to any specific relationship between organism and tissue or not? Diphtheria in man usually attacks the tonsils first, gonorrhoea and syphilis the external genitals, tuberculosis the lung, "cholera" the small intestine, "dysenteries" the large intestine, influenza the lungs. In these cases the explanation is probably that the points attacked are the places where the organism is most commonly carried, with no specific relationship, since all of these organisms (Asiatic cholera excepted) also produce lesions in other parts of the body *when they reach them*. On the other hand, the virus of hydrophobia attacks nerve cells, leprosy frequently singles out nerves, glanders bacilli introduced into the abdominal cavity of a young male guinea-pig cause an inflammation of the testicle, malarial parasites and piroplasms attack the red blood corpuscles, etc. In fact, most *pathogenic protozoa* are specific in their localization either in certain tissue cells or in the blood or lymph. In these cases there is apparently a real chemical relationship, as there is also between the *toxins* of bacteria and certain tissue cells (tetanus toxin and nerve cells). Whether "chemotherapy" will ever profit from a knowledge of such chemical relationship remains to be developed. It appears that a search for these specific chemical substances with the object of combining poisons with them so that the organisms might in this way be destroyed would be a profitable line of research.

## CHAPTER XXV.

### IMMUNITY.

IMMUNITY, as has already been stated, implies such a condition of the body that pathogenic organisms after they have been introduced are incapable of manifesting themselves and are unable to cause disease. The word has come to have a more specific meaning than resistance in many instances, in other cases the terms are used synonymously. It is the opposite of susceptibility. The term must be understood always in a relative sense, since no animal is immune to all pathogenic organisms, and conceivably not entirely so to anyone, because there is no question that a sufficient number of bacteria of any kind might be injected into the circulation to kill an animal even though it did it purely mechanically.

Immunity may be considered with reference to a single individual or to entire divisions of the organic world, with all grades between. Thus plants are immune to the diseases affecting animals; invertebrates to vertebrate diseases; cold-blooded animals to those of warm blood; man is immune to most of the diseases affecting other mammals; the rat to anthrax, which affects other rodents and most mammals; the well-known race of Algerian sheep is likewise immune to anthrax while other sheep are susceptible; the negro appears more resistant to yellow fever than the white; some few individuals in a herd of hogs always escape an epizootic of hog cholera, etc.

Immunity within a given species is modified by any of the following: age, state of nutrition, vitamine deficiencies, extremes of heat or cold, fatigue, excesses of any kind. In fact, anything which tends to lower the "normal healthy tone" of an animal also tends to lower its resistance. Children appear

more susceptible to scarlet fever, measles, whooping cough, etc., than adults; young cattle more frequently have black-leg than older ones (these apparently greater susceptibilities may be due in part to the fact that most of the older individuals have had the diseases when young and are immune for this reason). Animals weakened by hunger or thirst succumb to infection more readily. Frogs and chickens are immune to tetanus, but if the former be put in water and warmed up to and kept at about 37° C. and the latter be chilled for several hours in ice-water, then each may be infected. Pneumonia frequently follows exposure to cold. The immune rat may be given anthrax if first he is made to run in a "squirrel cage" until exhausted. Alcoholics are far less resistant to infection than temperate individuals. "Worry," mental anguish, tend to predispose to infection.

The following outlines summarize the different classifications of immunity so far as mammals are concerned for the purposes of discussion.

Immunity.

- |   |  |   |   |   |   |  |   |
|---|--|---|---|---|---|--|---|
| I. Natural  | <table border="0"> <tr> <td style="vertical-align: middle;">A. Congenital</td> <td rowspan="2" style="font-size: 3em; vertical-align: middle;">}</td> <td rowspan="2">                     1. Inherited through the germ cell or cells.<br/>                     2. Acquired <i>in utero</i>.                 </td> <td rowspan="2" style="font-size: 3em; vertical-align: middle;">{</td> <td rowspan="2">                     (a) By having the disease <i>in utero</i>.<br/>                     (b) By absorption of immune substances from the mother.                 </td> </tr> <tr> <td style="vertical-align: middle;">B. Acquired <i>post partum</i> by having the disease.</td> </tr> </table> | A. Congenital   | } | 1. Inherited through the germ cell or cells.<br>2. Acquired <i>in utero</i> . | { | (a) By having the disease <i>in utero</i> .<br>(b) By absorption of immune substances from the mother. | B. Acquired <i>post partum</i> by having the disease. |
| A. Congenital   | }  | 1. Inherited through the germ cell or cells.<br>2. Acquired <i>in utero</i> . |   |   |   |  | {   |
| B. Acquired <i>post partum</i> by having the disease.   |  |   |   |   |   |  |   |
| II. Artificial—acquired through human agency by:        |  |   |   |   |   |  |   |
| 1. Introduction of the organism or its products.        |  |   |   |   |   |  |   |
| 2. Introduction of the blood serum of an immune animal. |  |   |   |   |   |  |   |

Immunity.

- I. Active—due to the introduction of the organism or due to the introduction of the products of the organism.
- A. Naturally by having the disease.
- B. Artificially.
1. By introducing the organism:
- |   |                         |   |  |  |           |  |
|---|-------------------------|---|--|--|-----------|--|
| <table border="0"> <tr> <td style="vertical-align: middle;">(a) Alive and virulent.</td> <td rowspan="7" style="font-size: 3em; vertical-align: middle;">}</td> <td rowspan="7">                     1. Passage through another animal.<br/>                     2. Drying.<br/>                     3. Growing at a higher temperature.<br/>                     4. Heating the cultures.<br/>                     5. Treating with chemicals.<br/>                     6. Sensitizing.<br/>                     7. Cultivation on artificial media.                 </td> </tr> <tr> <td style="vertical-align: middle;">(b) Alive and virulence reduced by</td> </tr> <tr> <td style="vertical-align: middle;">(c) Dead.</td> </tr> </table> | (a) Alive and virulent. | } | 1. Passage through another animal.<br>2. Drying.<br>3. Growing at a higher temperature.<br>4. Heating the cultures.<br>5. Treating with chemicals.<br>6. Sensitizing.<br>7. Cultivation on artificial media. | (b) Alive and virulence reduced by   | (c) Dead. |  |
| (a) Alive and virulent.   | }                       |   |  | 1. Passage through another animal.<br>2. Drying.<br>3. Growing at a higher temperature.<br>4. Heating the cultures.<br>5. Treating with chemicals.<br>6. Sensitizing.<br>7. Cultivation on artificial media. |           |  |
| (b) Alive and virulence reduced by  |                         |   |  |  |           |  |
| (c) Dead.   |                         |   |  |  |           |  |
| 2. By introducing the products of the organism.   |                         |   |  |  |           |  |
- II. Passive—due to the introduction of the blood serum of an actively immunized animal.

Immunity present in an animal and not due to human interference is to be regarded as *natural* immunity, while if brought about by man's effort it is considered *artificial*. Those cases of natural immunity mentioned above which are common to divisions, classes, orders, families, species or races of organisms and to those few individuals where no special cause is discoverable, must be regarded as instances of true *inheritance* through the germ cell as other characteristics are. All other kinds of immunity are *acquired*. Occasionally young are born with every evidence that they have had a disease *in utero* and are thereafter as immune as though the attack had occurred after birth ("small-pox babies," "hog-cholera pigs"). Experiment has shown that immune substances may pass from the blood of the mother to the fetus *in utero* and the young be immune for a time after birth (tetanus). This is of no practical value as yet. It is a familiar fact that with most infectious diseases recovery from one attack confers a more or less lasting immunity, though there are marked exceptions.

**Active Immunity.**—By active immunity is meant that which is due to the actual introduction of the organism, or in some cases of its products. The term active is used because the body cells of the animal immunized perform the real work of bringing about the immunity as will be discussed later. In *passive* immunity the blood serum of an actively immunized animal is introduced into a second animal, which thereupon becomes immune, though its cells are not concerned in the process. The animal is *passive*, just as a test-tube, in which a reaction takes place, plays no other part than that of a passive container for the reagents.

In *active* immunity the organism may be introduced in what is to be considered a natural manner, as when an animal becomes infected, has a disease, without human interference. Or the organism may be purposely introduced to bring about the immunity. For certain purposes the introduction of the products of the organism (toxins) is used to bring about active immunity (preparation of diphtheria and tetanus antitoxin from the horse, immunization of children against diphtheria by toxin-antitoxin injections). The method



of producing active immunity by the artificial introduction of the organism is called *vaccination*, and a *vaccine* must therefore contain the organism. *Vaccines* for *bacterial* diseases are frequently called *bacterins*. The use of the blood serum of an immunized animal to confer passive immunity on a second animal is properly called *serum therapy*, and the serum so used is spoken of as an *antiserum*, though the latter word is also used to denote any serum containing any kind of an antibody (Chapters XXVII-XXXI). In a few instances both the organism and an antiserum are used to cause both active and passive immunity (*serum-simultaneous method* in immunizing against hog cholera).

In producing active immunity the organism may be introduced (a) *alive and virulent*, but in very small doses, or in combination with an immune serum, as just mentioned for hog cholera. The introduction of the live virulent organism alone is done only experimentally as yet, as it is obviously too dangerous to do in practice, except under the strictest control (introduction of a *single tubercle* bacillus, followed by gradually increasing numbers—Barber and Webb). More commonly the organisms are introduced (b) *alive but with their virulence reduced* (“attenuated”) in one of several ways: (1) By passing the organism through another animal, as is the case with *small-pox vaccine* derived from a calf or heifer. This method was first introduced by Jenner in 1795 and was the first practical means of preventing disease by *vaccination*. This word was used because material was derived from a cow—Latin *vacca*. (2) By drying the organism, as is done in the preparation of the vaccine for the *Pasteur treatment of rabies*, where the spinal cords of rabbits are dried for varying lengths of time—one to four days, Russian method, one to three days, German method, longer in this country. (It is probable that the passage of the “fixed virus” through the rabbit is as important in this procedure as the drying, since it is doubtful if the “fixed virus” is pathogenic for man.) It would be more correct to speak of this as a *preventive vaccination against rabies*, since the latter is one of the few diseases which is not amenable to *treatment*. The patient always dies if the disease develops. (3) The

organism may be attenuated by growing at a temperature above the optimum. This is the method used in preparing *anthrax vaccine* as done by Pasteur originally. (4) Instead of growing at a higher temperature the culture may be heated in such a way that it is not killed but merely weakened. *Black-leg* vaccines are made by this method. (5) Chemicals are sometimes added to attenuate the organisms, as was formerly done in the preparation of black-leg vaccine by Kruse's method in Germany. The use of toxin-antitoxin mixtures in immunizing against diphtheria and in the preparation of diphtheria antitoxin from horses is an application of the same principle, though here it is the *product* of the organism and not the organism whose action is weakened. (6) Within the past few years the workers in the Pasteur Institute in Paris have been experimenting with vaccines prepared by treating living virulent bacteria with antisera ("sensitizing them"), so that they are no longer capable of causing the disease when introduced, but do cause the production of an active immunity. The method has been used with typhoid fever bacilli in man and seems to be successful. It remains to be tried out further before its worth is demonstrated (the procedure is more complicated and the chance for infection apparently much greater than by the use of killed cultures). The term *sero-bacterins* is used by manufacturers in this country to designate such bacterial vaccines. (7) Growing on artificial culture media reduces the virulence of most organisms after a longer or shorter time. This method has been tried with many organisms in the laboratory. The difficulties are that the attenuation is very uncertain and that the organisms tend to regain their virulence when introduced into the body.

B. C. G. (*Bacillus* of Calmette-Guerin) a culture of the tubercle bacillus grown by Calmette and Guerin on a special bile medium for thirteen years to reduce its virulence is now being tried out extensively in France and other countries of Europe as a preventive of tuberculosis. It is given new-born babies by mouth. Repetition of the vaccination after four or five years is recommended by Calmette. The efficacy of the method remains to be demonstrated.

In producing active immunity against many bacterial

diseases the organisms are introduced (*c*) dead. They are killed by heat or by chemicals, or by using both methods (Chapter XXX).

When the products of an organism are introduced the resulting immunity is against the products only and not against the organism. If the organism itself is introduced there results an immunity against it and in some cases also against the products, though the latter does not necessarily follow. Hence the immunity may be *antibacterial* or *antitoxic* or both.

Investigation as to the causes of immunity and the various methods by which it is produced has not resulted in the discovery of specific methods of treatment for as many diseases as was hoped for at one time. Just at present progress in serum therapy appears to be at a standstill, though vaccines are giving good results in many instances not believed possible a few years ago. As a consequence workers in all parts of the world are giving more and more attention to the search for *specific chemical substances*, which will destroy invading parasites and not injure the host (*chemotherapy*). Nevertheless, in the study of immunity very much of value in the treatment and prevention of disease has been learned. Also much knowledge which is of the greatest use in other lines has been accumulated. Methods of *diagnosis* of great exactness have resulted, applicable in numerous diseases. Ways of *detecting adulteration* in foods, particularly foods from animal sources, and of *differentiating proteins* of varied origin, as well as means of establishing *biological relationships* and differences among groups of animals and determining whether the bloods of two human beings are *alike for purposes of transfusion* through "immunity reactions" of blood serums have followed from knowledge gained by application of the facts or the methods of immunity research. Hence the study of "immunity problems" has come to include much more than merely the study of those factors which prevent the development of disease in an animal or result in its spontaneous recovery. A proper understanding of the principles of immunity necessitates a study of these various features and they will be considered in the discussion to follow.

## CHAPTER XXVI.

### THEORIES OF IMMUNITY.

PASTEUR and the bacteriologists of his time discovered that bacteria cease to grow in artificial culture media after a time, because of the exhaustion of the food material in some cases and because of the injurious action of their own products in other instances. These facts were brought forward to explain immunity shortly after bacteria were shown to be the cause of certain diseases. Theories based on these observations were called (1) "*Exhaustion Theory*" of Pasteur, and (2) "*Noxious Retention Theory*" of Chauveau respectively. The fact, soon discovered, that virulent pathogenic bacteria are not uncommonly present in perfectly healthy animals, and the later discovery that immunity may be conferred by the injection of dead bacteria have led to the abandonment of both these older ideas. The (3) "*Unfavorable Environment*" theory of Baumgartner, *i. e.*, bacteria do not grow in the body and produce disease because their surroundings are not suitable, in a sense covers the whole ground, though it is not true as to the first part, as was pointed out above, and is of no value as a working basis, since it offers no explanation as to *what the factors are* that constitute the "*unfavorable environment.*" Metchnikoff brought forward a rational explanation of immunity with his (4) "*Cellular or Phagocytosis Theory.*" As first propounded it based immunity on the observed fact that certain white blood corpuscles, *phagocytes*, engulf and destroy bacteria. Metchnikoff later elaborated the original theory to explain facts of subsequent discovery. Ehrlich soon after published his (5) "*Chemical or Side-chain Theory,*" which seeks to explain immunity on the basis of *chemical substances* in the body which may in part destroy pathogenic organisms

PLATE II



ELIE METCHNIKOFF



PLATE III



PAUL EHRLICH





or in part neutralize their products; or in some instances there may be an absence of certain chemical substances in the body cells so that bacteria or their products *cannot unite* with the cells and hence can do no damage.

At the present time it is generally accepted, in this country at least, that Ehrlich's theory explains immunity in many diseases as well as many of the phenomena related to immunity, and in other diseases the phagocytes, frequently assisted by chemical substances, are the chief factors. Specific instances are discussed in *Pathogenic Bacteriologies* which should be consulted. It is essential that the student should be familiar with the basic ideas of the chemical theory, not only from the standpoint of immunity, but also in order to understand the principles of a number of valuable methods of diagnosis.

The chemical theory rests on three fundamental physiological principles: (1) The response of cells to stimuli, in this connection *specific chemical stimuli*, (2) the presence within cells of *specific chemical groups* which combine with chemical stimuli and thus enable them to act on the cell, which groups Ehrlich has named *receptors*, and (3) the "*overproduction*" activity of cells as announced by Weigert.

1. That cells respond to stimuli is fundamental in physiology. These stimuli may be of many kinds as mechanical, electrical, light, thermal, chemical, etc. The body possesses groups of cells specially developed to *receive* some of these stimuli—touch cells for mechanical stimuli, retinal cells for light, temperature nerve endings for thermal, olfactory and gustatory cells for certain chemical stimuli. *Response* to chemical stimuli is well illustrated along the digestive tract. That the chemical stimuli in digestion may be more or less specific is shown by the observed differences in the enzymes of the pancreatic juice dependent on the relative amounts of carbohydrates, fats or proteins in the food, the specific enzyme in each case being increased in the juice with the increase of its corresponding foodstuff. The cells of the body, or certain of them at least, seem to respond in a specific way when substances are brought into direct contact with them, that is, without having been subjected to

digestion in the alimentary tract, but injected directly into the blood or lymph stream. Cells may be affected by stimuli in one of three ways: If the stimulus is too weak, there is no effect (in reality there is no "stimulus" acting); if the stimulus is too strong the cell is injured, or may be destroyed; if the stimulus is of proper amount then it excites the cell to increased activity, and in the case of *specific chemical stimuli* the increased activity, as mentioned for the pancreas, shows itself in an *increased production of whatever is called forth by the chemical stimulus*. In the case of many organic chemicals the substances produced by the cells under their direct stimulation are markedly specific for the particular substance introduced.

2. Since chemical action always implies at least two bodies to react, Ehrlich assumes that in every cell which is affected by a chemical stimulus there must therefore be a chemical group to unite with this stimulus. He further states that there must be as many different kinds of these groups as there are different kinds of chemicals which stimulate the cell. Since these groups are present in the body cells to *take up* different kinds of chemical substances, Ehrlich calls them *receptors*. Since these groups must be small as compared with the cell as a whole, and must be more or less on the surface and unite readily with chemical substances, he further speaks of them as "side-chains" after the analogy of compounds of the aromatic series especially. The term *receptors* is now generally used. They are also called *haptins*. As was stated above, the effect of *specific chemical stimuli* is to cause the production of *more of the particular substance* for which it is specific and in the class of bodies under discussion, the *particular product is these cell receptors* with which the chemical may unite.

3. Weigert first called attention to the practically constant phenomenon that cells ordinarily respond by doing more of a particular response than is actually called for by the stimulus, that there is always an "overproduction" of activity. In the case of chemical stimuli this means an *increased production of the specific substance* over and above the amount actually needed.

The student will better understand this theory if he recalls his fundamental physiology. Living substance is characterized, among other things, by irritability, which is instability. It is in a constant state of unstable equilibrium. Whenever the equilibrium becomes permanently stable the substance is dead. It is also continually attempting to restore disturbances in its equilibrium. Whenever a chemical substance unites with a chemical substance in the cell, a receptor, the latter is, so far as the cell is concerned, *thrown out of function* for that cell. The chemical equilibrium of the latter is upset. It attempts to restore this and does so by making a *new* receptor to take the place of the one thrown out of function hence the *chemical combination* between the chemical substance introduced and the cell receptor *is the stimulus which causes the cell to make a new receptor*. If this process is continued, *i. e.*, if the new receptor is similarly "used up" and others similarly formed are also, then the cell will prepare a supply of these and even an excess, according to Weigert's theory. Whenever a cell accumulates an excess of products the normal result is that it excretes them from its own substance into the surrounding lymph, whence they reach the blood stream to be either carried to the true excretory organs, utilized by other cells or remain for a longer or shorter time in the blood. Hence the excess of receptors is *excreted from the cell that forms them* and they become *free* in the blood. These free receptors are termed *antibodies*. *They are receptors*, but instead of being retained in the cell are *free in solution in the blood*. One function of the free receptor, the antibody, is *always to unite with the chemical substance which caused it to be formed*. It may have additional functions. The chemical substance which caused the excess formation of receptors, antibodies, is termed an *antigen* for that particular kind of antibody.

To recapitulate, Ehrlich's theory postulates *specific chemical stimuli*, which react with *specific chemical substances in the body cells*, named *receptors*, and that these *receptors*, according to Weigert, are *produced in excess* and hence are excreted from the cell and become *free receptors* in the blood and lymph. These *free receptors* are the various kinds of *antibodies*, the kind depending on the nature of the stimulus,

*antigen*, the substance introduced. Any substance which when introduced into the body causes the formation of an antibody of any kind whatsoever is called an *antigen*,<sup>1</sup> *i. e.*, anti (body) former.

The foregoing discussion explains Ehrlich's theory of immunity. According to this theory the *manner of formation of all antibodies* is the same. The *kind of antibody* and the *manner of its action* will differ with the *different kinds of antigens* used.

The succeeding chapters discuss some of the kinds of antibodies, the theory of their action and some practical applications. It must be borne in mind throughout the study of these, as has been stated, that *every antibody has the property of uniting with its antigen whether it has any property in addition or not.*

Just what antibodies are chemically has not been determined because no one has as yet succeeded in isolating them chemically pure. To the author they appear to be enzymes.

Antigens were considered by Ehrlich to be proteins or to be related to proteins. Most workers since Ehrlich have held similar views. Dr. Carl C. Warden, of the University of Michigan, has been doing much work in recent years in which he is attempting to show that the antigens are not proteins but are fats or fatty acids. Mr. E. E. H. Boyer, in his work in the author's laboratory for the degree of Ph.D., received in June, 1920, succeeded in producing various antibodies from *Escherichia coli* antigens. In these antigens he could detect only fatty acids or salts of fatty acids. If the work of these men is confirmed it will open up a most interesting and extremely important field in immunity and in preventive medicine. It is not apparent that the nature of the antigen would affect Ehrlich's theory of the formation of antibodies.

The author has no doubt that eventually the formation of antibodies and the reactions between them and their antigens will be explained on the basis of physical-chemical laws, but this probably awaits the discovery of their nature.

<sup>1</sup> The term "antigen" is also used to designate substance which may take the place of what are supposed to be the true antigens in certain diagnostic reactions (Chapter XXIX, Complement-fixation Test for Syphilis).

## CHAPTER XXVII.

### RECEPTORS OF THE FIRST ORDER.

#### ANTITOXINS—ANTIENZYMES.

THE general characteristics of toxins have been described (Chapter XII). It has been stated that they are more or less specific in their action on cells. In order to affect a cell it is evident that a toxin must enter into chemical combination with it. This implies that the toxin molecule possesses a chemical group which can combine with a receptor of the cell. This group is called the *haptophore* or combining group. The toxic or injurious portion of the toxin molecule is spoken of as the *toxophore* group. When a toxin is introduced into the body its *haptophore* group combines with suitable *receptors* in different cells of the body. If not too much of the toxin is given, instead of injuring, it acts as a chemical stimulus to the cell in the manner already described. The cell in response produces more of the specific thing, which in this instance is more receptors which can combine with the toxin, *i. e.*, with its *haptophore* group. If the stimulus is kept up, more and more of these receptors are produced until an excess for the cell accumulates, which excess is excreted from the individual cell and becomes free in the blood. These free receptors have, of course, the capacity to combine with toxin through its *haptophore* group. When the toxin is combined with these free receptors, it can not combine with any other receptors, *e. g.*, those in another cell and hence cannot injure another cell. These free receptors constitute, in this case, *antitoxin*, so-called because they can combine with toxin and hence neutralize it. Antitoxins are specific—that is, an antitoxin which will combine with the toxin of *Clostridium tetani* will not combine with that of *Corynebacterium diphtheriæ*, or of *Clostridium botulinum*, or of any other toxin, vegetable or animal.

When a toxin is kept in solution for some time or when it is heated above a certain temperature (different for each toxin) it loses its poisonous character. It may be shown, however, that it is still capable of uniting with antitoxin, and preventing the latter from uniting with a fresh toxin. This confirms the hypothesis that a toxin molecule has at least two groups: A combining or *haptophore*, and a poisonous or *toxophore* group. A toxin which has lost its poisonous property, its toxophore group, is spoken of as a *toxoid*. The theory of antitoxin formation is further supported by the fact that the proper introduction of *toxoid*, the *haptophore* group, and hence the real stimulus, can cause the production of *antitoxin* to a certain extent at least.

The close relationship between toxins and enzymes has already been pointed out. This is still further illustrated by the fact that when enzymes are properly introduced into the tissues of an animal there is formed in the animal an *antienzyme* specific for the enzyme in question which can prevent its action. The structure of enzymes, as composed of a *haptophore*, or uniting, and a *zymophore* or *digesting* (or other activity) group, is similar to that of toxins, and *enzymoids* or enzymes which can combine with the substance acted on but not affect it further, have been demonstrated.

These free cell receptors, antitoxins or antienzymes, which are produced in the body by the proper introduction of toxins or enzymes, respectively, have the function of *combining* with these bodies *but no other action*. As was pointed out above, this is sufficient to neutralize the toxin or enzyme and prevent any injurious effect since they can unite with nothing else. Since these receptors are the simplest type which has been studied as yet, they are spoken of by Ehrlich as *receptors or haptins of the first order*. Other antibodies which are likewise free receptors of the first order and have the function of combining only have been prepared and will be referred to in their proper connection. They are mainly of theoretical interest.

Ehrlich did a large part of his work on toxins and antitoxins with *ricin*, the toxin of the castor-oil bean, *abrin*, from the jequirity bean, *robin* from the locust tree, and with the toxins and antitoxins for diphtheria and tetanus. Anti-

toxins have been prepared experimentally for a large number of both animal and vegetable poisons, including a number for bacterial toxins. The only ones which, as yet, are of much practical importance are *antivenin* for snake poison (not a true toxin, however, see page 272), *antipollenin* (supposed to be for the toxin of hay fever) and the antitoxins for the true bacterial toxins of *Corynebacterium diphtheriæ* and *Clostridium tetani*. Antitoxins for the two types, A and B, of the toxins of *Clostridium botulinum* have been prepared and tried out in some few cases of human food poisoning, but unfortunately they have been used too late to be of much value. In experiments with animals they have been shown to be as specific as other antitoxins.

The method of preparing antitoxins is essentially the same in all cases, though differing in minor details. For commercial purposes large animals are selected, usually horses, so that the yield of serum may be large. The animals must, of course, be vigorous, free from all infectious disease. The first injection given is either a relatively small amount of a solution of toxin or of a mixture of toxin and antitoxin. The animal shows more or less reaction, increased temperature, pulse and respiration and frequently an edema at the point of injection, unless this is made intravenously. After several days to a week or more, when the animal has recovered from the first injection, a second stronger dose is given, usually with less reaction. Increasingly large doses are given at proper intervals until the animal may take several hundred times the amount which would have been fatal if given at first. The process of immunizing a horse for diphtheria or tetanus toxin usually takes several months. Variations in time and in yield of antitoxin are individual and not predictable in any given case.

After several injections a few hundred cubic centimeters of blood are withdrawn from the jugular vein and serum from this is tested for the amount of antitoxin it contains. When the amount is found sufficiently large (250 "units" at least for diphtheria per cc)<sup>1</sup> then the maximum amount of blood is collected from the jugular with sterile trocar and

<sup>1</sup> If the antitoxin is later concentrated (see last paragraph in this chapter) a serum containing as little as 175 units per cc may be commercially profitable.

cannula. The serum from this blood with the addition of an antiseptic (0.5 per cent phenol, tricresol, etc.) constitutes "antidiphtheritic serum" or "antitetanic serum," etc. All sera which are put on the market must conform to definite standards of strength expressed in "units" as determined by the U. S. Hygienic Laboratory. In reality a "unit" of diphtheria antitoxin in the United States is an amount equivalent to 1 cc of a given solution of a *standard* diphtheria antitoxin, which is kept at the above-mentioned laboratory. This statement, of course, gives no definite idea as to the amount of antitoxin actually in a "unit." Specifically stated, a "unit" of antitoxin contains approximately the amount which would protect a 250 g. guinea-pig from 100 minimum lethal doses of diphtheria toxin, or protect 100 guinea-pigs weighing 250 g. each from 1 minimum lethal dose each. The minimum lethal dose (M. L. D.) of diphtheria toxin is the least amount that will kill a guinea-pig of the size mentioned within four days. Since toxins on standing change into toxoids to a great extent, the amount of antitoxin in a "unit," though protecting against 100 M. L. D., in reality would protect against about 200 M. L. D. of toxin containing no toxoid.

The official unit for tetanus antitoxin is somewhat different, since it is standardized against a *standard toxin* which is likewise kept at the Hygienic Laboratory. The unit is defined as "ten times the amount of antitoxin necessary to protect a 350 g. guinea-pig for ninety-six hours against the *standard test dose*" of the standard toxin. The standard test dose is 100 M. L. D. of toxin for a 350 g. guinea-pig. To express it another way, one could say that a "unit" of tetanus antitoxin would protect 1000 350 g. guinea-pigs from 1 M. L. D. each of standard tetanus toxin.

Various methods have been devised for increasing the amount of antitoxin in 1 cc of solution by precipitating out portions of the blood-serum proteins and at the same time concentrating the antitoxin in smaller volume. It is not considered necessary in a work of this character to enter into these details nor to discuss the process of standardizing antitoxins so that the exact amount of "units" per cubic centimeter may be known.



## CHAPTER XXVIII.

### RECEPTORS OF THE SECOND ORDER.

#### AGGLUTININS.

CHARRIN and Rogers appear to have been the first (1889) to observe the clumping together of bacteria (*Pseudomonas aëruuginosa*) when mixed with the blood serum of an animal immunized against them. Gruber and Durham (1896) first used the term "agglutination" in this connection and called the substance in the blood-serum "agglutinin." Widal (1896) showed the importance of the reaction for diagnosis by testing the blood serum of an infected person against a known culture (typhoid fever).

It is now a well-known phenomenon that the proper injection of cells of any kind foreign to a given animal will lead to the accumulation in the animal's blood of substances which will cause a clumping together of the cells used when suspended in a suitable liquid. The cells settle out of such suspension much more rapidly than they would otherwise do. This clumping is spoken of as "agglutination" and the substances produced in the animal are called "agglutinins." If blood cells are injected then "hemagglutinins" result: If bacterial cells, "bacterial agglutinins" for the particular organism used as "glanders agglutinin" for *Pfeifferella mallei*, "abortion agglutinin" for *Alcaligenes abortus*, "typhoid agglutinin" for *Eberthella typhi*.

The phenomenon may be observed either under the microscope or in small test-tubes, that is, either *microscopically* or *macroscopically*.

In this case the cells introduced, or more properly, some substances within the cells, act as stimuli to the body cells of the animal injected to cause them to produce more of the specific cell receptors which respond to the stimulus. The

substance within the introduced cell which acts as a stimulus (*antigen*) to the body cells is called an "*agglutinogen*." That "agglutinogen" is present in the cell has been shown by injecting animals experimentally with extracts of cells (bacterial and other cells) and the blood serum of the animal injected showed the presence of agglutinin for the given cell. It will be noticed that the receptors which become the free agglutinins have at least *two functions*, hence at least two *chemical groups*. They must combine with the foreign cells and also bring about their clumping together, their agglutination. Hence it can be stated technically that an agglutinin possesses a *haptophore group* and an *agglutinating group*.

It is probable that the agglutination, the clumping, is a secondary phenomenon depending on the presence of certain salts and that the agglutinin acts on its antigen as an enzyme, possibly a "splitting" enzyme. This is analogous to what occurs in the curdling of milk by rennet and in the coagulation of blood. This probability is substantiated by the fact that suspensions of bacteria may be "agglutinated" by appropriate strengths of various acids.

The formation of agglutinin in the body for different bacteria does not as yet appear to be of any special significance in protecting the animal from the organism, since the bacteria are not killed, even though they are rendered non-motile, if of the class provided with flagella, and are clumped together. The fact that such bodies are formed, however, is of decided value in the diagnosis of disease, and also in the identification of unknown bacteria.

In many bacterial diseases, agglutinins for the particular organism are present in the blood serum of the affected animal. Consequently if the blood serum of the animal be mixed with a suspension of the organism supposed to be the cause of the disease and the latter be agglutinated, one is justified in considering it the causative agent, provided certain necessary conditions are fulfilled. In the first place it must be remembered that the blood of normal animals frequently contains agglutinins ("normal agglutinins") for many different bacteria when mixed with them in full

strength. Hence the serum must always be diluted with physiological salt solution (0.85 per cent). Further, closely related bacteria may be agglutinated to some extent by the same serum. It is evident that if they are closely related, their protoplasm must contain some substances of the same kind to account for this relationship. Since some of these substances may be agglutinogens, their introduction into the animal body will give rise to agglutinins for the related cells, as well as for the cell introduced. The agglutinins for the cell introduced "chief agglutinins" will be formed in larger quantity, since a given bacterial cell must contain more of its own agglutinogen than that of any other cell. By *diluting the blood serum* from the animal to be tested the agglutinins for the related organisms (so-called "coagglutinins" or "partial agglutinins") will become so much diminished as to show no action, while the agglutinin for the specific organism is still present in an amount sufficient to cause its clumping. *Agglutinins are specific for their particular agglutinogens*, but since a given blood serum may contain many agglutinins, the *serum's specificity for a given bacterium* can be determined only by diluting it until this bacterium alone is agglutinated. Hence the necessity of diluting the unknown serum in varying amounts when testing against several known bacteria to determine for which it is specific, *i. e.*, which is the cause of the disease in the animal.

The agglutinins in the serum may be removed from it by treating it with a suspension of the cells for which agglutinins are present. If the "chief" cell is used all the agglutinins will be absorbed. If related cells are used, only the agglutinins for this particular kind are removed. These "absorption tests" furnish another means of determining specificity of serum, or rather of determining the "chief agglutinin" present.

Just as an unidentified *disease* in an animal may be determined by testing its serum as above described against *known* kinds of bacteria, so *unknown bacteria* isolated from an animal, from water, etc., may be identified by testing them against the *blood sera* of different animals, each of which has

been properly inoculated with a different kind of *known bacterium*. If the unknown organism is agglutinated by the blood of one of the animals in high dilution, and not by the others, evidently the bacterium is the same as that with which the animal has been inoculated, or *immunized*, as is usually stated. This method of identifying cultures of bacteria is of wide application, but is used practically only in those cases where other methods of identification are not readily applied, and especially where other methods are *not sufficient*, as in the "intestinal group" of organisms in human practice.

The diagnosis of disease in an animal by testing its serum is also a valuable and much used procedure. This is the method of the "Widal" or "Gruber-Widal" test for typhoid fever in man and is used in veterinary practice in testing for glanders, contagious abortion, etc. In some cases a dilution of the serum of from 20 to 50 times is sufficient for diagnosis (Malta fever), in most cases, however, 50 times is the lowest limit. Evidently the greater the dilution, that is, the higher the "titer," the more specific is the reaction.

The agglutination test is also one way of determining whether two human bloods belong to the proper class when it is desired to transfuse from one person to another. There are four classes of blood with respect to the agglutination between the red corpuscles and the plasma or serum. The test is likewise of some value in determining the parents of a child.

### PRECIPITINS.

Since agglutinins act on bacteria, probably through the presence of substances within the bacterial cell, it is reasonable to expect that if these substances be dissolved out of the cell, there would be some reaction between their (colloidal) solution and the same serum. As a matter of fact, Kraus (1897) showed that broth cultures freed from bacteria by porcelain filters do show a precipitate when mixed with the serum of an animal immunized against the particular bacterium and that the reaction is specific under proper conditions of dilution. It was not long after Kraus's work until

the experiments were tried of "immunizing" an animal not against a bacterium or its filtered culture, but against (colloidal) solutions of proteins, such as white of egg, casein of milk, proteins of meat and of blood serum, vegetable proteins, etc. It was ascertained that in all these cases the animal's serum contains a substance which causes a *precipitate* with solutions of the protein used for immunization. The number of such precipitating serums that have been made experimentally is very large and it appears that protein from any source when properly introduced into the blood or tissues of an animal will cause the formation of a precipitating substance for its solutions. This substance is known technically as a "*precipitin*." The protein used as antigen to stimulate its formation, or some part of the protein molecule (haptophore group), which acts as stimulus to the cell is spoken of as a "*precipitinogen*," both terms after the analogy of "*agglutinin*" and "*agglutinogen*." In fact the specific precipitation and agglutination are strictly analogous phenomena. Precipitins act on proteins in (colloidal) *solution* and cause them to settle out, agglutinins act on substances within cells, which cells are in *suspension* in a fluid and cause the cells to settle out. Ehrlich's theory of the formation of precipitins is similar to that of agglutinins and need not be repeated. Substitute the corresponding words in the theory of formation of agglutinins as above given and the theory applies.

The precipitin reaction has not found much practical use in bacteriology, largely because the "agglutination test" takes its place as simpler of performance and just as accurate. The reaction is, however, generally applicable to filtrates of bacterial cultures and could be used if needed. The so-called "mallease" reaction in glanders is an instance.

Precipitins find their greatest usefulness in legal medicine and in food adulteration work. As was noted above, if animals, rabbits for example, are immunized with the blood of another animal (human beings) precipitins are developed which are specific for the injected blood with proper dilution. This forms an extremely valuable means of determining the *kind of blood* present in a given spot

shown by chemical and spectroscopic tests to be blood and has been adopted as a legal test in countries where such rules of procedure are applied. Similarly the test has been used to identify the different kinds of meat in sausage and different kinds of milk in a mixture. An extract of the sausage is made and tested against the serum of an animal previously treated with extract of horse meat, or hog meat, or beef, etc., the specific precipitate occurring with the specific serum. Such reactions have been obtained where the protein to be tested was diluted 100,000 times and more. Biological relationships and differences have been detected by the reaction. Human immune serum shows no reaction with the blood of any animals except to a slight extent with that of various monkeys, most with the higher, very slight with the lower Old World and scarcely any with New World monkeys.

It is a fact of theoretical interest mainly that if agglutinins and precipitins themselves be injected into an animal they will act as *antigens* and cause the formation of *antiagglutinins* or *antiprecipitins*, which are therefore receptors of the first order, since they simply combine with these immune bodies to neutralize their action, have only a combining or haptophore group. Also if agglutinins or precipitins be heated to the proper temperature they may retain their combining power but cause no agglutination or precipitation, *i. e.*, they are converted into agglutinoid or precipitinoid respectively after the analogy of toxin and toxoid.

Precipitins like agglutinins possess at least two groups—a combining or *haptophore* group and a *precipitating* (sometimes called *zymophore*) group. Hence they are somewhat more complex than antitoxins or antienzymes which have a combining group only. For this reason Ehrlich classes agglutinins and precipitins as *receptors or haptins of the second order*.

## CHAPTER XXIX.

### RECEPTORS OF THE THIRD ORDER.

#### CYTOLYSINS.

BEFORE Koch definitely proved bacteria capable of causing disease, several physiologists had noted that the red corpuscles of certain animals were destroyed by the blood of other animals (Creite, 1869, Landois, 1875), and Traube and Gescheidel had shown that freshly drawn blood destroys bacteria (1874). It was not until about ten years afterward that this action of the blood began to be investigated in connection with the subject of immunity. Von Fodor (1885) showed that saprophytic bacteria injected into the blood are rapidly destroyed. Flügge and his pupils, especially Nuttall, in combating Metchnikoff's theory of phagocytosis, announced in 1883, studied the action of the blood on bacteria and showed its destructive effect (1885-87). Nuttall also showed that the blood lost this power if heated to 56°. Buchner (1889) gave the name "alexin" (from the Greek "to ward off") to the destroying substance and showed that the substance was present in the *blood serum* as well as in the whole blood, and that when the serum lost its power to dissolve, this could be restored by adding fresh blood. Pfeiffer (1894) showed that the destructive power of the blood of animals immunized against bacteria (cholera and typhoid) was markedly specific for the bacteria used. He introduced a mixture of the blood and the bacteria into the abdominal cavity of the immunized animal or of a normal one of the same species and noted the rapid solution of the bacteria by withdrawing portions of the peritoneal fluid and examining them ("Pfeiffer's phenomenon"). Belfanti and Carbone, and especially Bordet (1898), showed the specific dissolving action of the serum of one animal on the blood corpuscles of another animal with which it had been injected.

Since this time the phenomenon has been observed with a great variety of cells other than red blood corpuscles and bacteria—leukocytes, spermatozoa, cells from liver, kidney, brain, epithelia, etc., protozoa and many vegetable cells.

It is therefore a well-established fact that the proper injection of an animal with almost any cell foreign to it will lead to the blood of the animal injected acquiring the power to injure or destroy cells of the same kind as those introduced. The destroying power of the blood has been variously called its "cytotoxic" or "cytolytic" power, though the terms are not strictly synonymous since "cytotoxic" means "cell poisoning" or "injuring," while "cytolytic" means "cell dissolving." The latter term is the one generally used and there is said to be present in the blood a specific "cytolysin." The term is a general one and a given cytolysin is named from the cell which is dissolved, as a *bacteriolysin*, a *hemolysin* (red-corpuscle-lysin), *epitheliolysin*, *nephrolysin* (for kidney cells), etc. If the cell is *killed* but not *dissolved* the suffix "cidin" or "toxin" is frequently used as "bacteriocidin," "spermatotoxin," "neurotoxin," etc.

The use of the term "cytolysin" is also not strictly correct, though convenient, for the process is more complex than if *one substance only* were employed. As was stated above, the immune serum loses its power to dissolve the cell if it is heated to 55° to 56° for half an hour, it is *inactivated*. But if there be added to the heated or inactivated serum a small amount of *normal serum* (which contains only a very little cytolytic substance, so that it has no dissolving power when so diluted) the mixture again becomes cytolytic. It is evident then that in cytolysis there are *two distinct substances* involved, one which is *present in all serum, normal or immune*, and the other *present in large quantity only in the immune cytolytic serum*. This may be more apparent if the facts are arranged in the following form:

- I. Immune serum dissolves cells in high dilution.
- II. Heated immune serum does not dissolve cells.
- III. Normal serum in high dilution does not dissolve cells.
- II. + III., *i. e.*, Heated immune serum plus diluted normal serum dissolves cells.



Therefore, there is something in heated immune serum necessary for cell dissolving and something different in diluted normal serum which is necessary. This latter something is present in unheated immune serum also and is destroyed by heat. Experiment has shown that it is the substance present in all serum both normal and immune that is the true dissolving body, while the immune substance serves to unite this body to the cell to be destroyed, *i. e.*, to the antigen. Since the immune body has therefore *two uniting groups*, one for the dissolving substance and one for the cell to be dissolved, Ehrlich calls it the "*amboceptor*." He also uses the word "*complement*" to denote the dissolving substance, giving the idea that it completes the action of dissolving after it has been united to the cell by the amboceptor, thus replacing Buchner's older term "*alexin*" for the same dissolving body.

#### AMBOCEPTORS.

The theory of formation of amboceptors is similar to that for the formation of the other types of antibodies. The cell introduced contains some substance which acts as a chemical stimulus to some of the body cells provided with proper receptors so that more of these special receptors are produced, and eventually in excess so that they become free in the blood and constitute the free amboceptors. It will be noticed that these free receptors differ from either of the two kinds already described in that they have *two uniting groups*, one for the antigen (cell introduced) named *cytophil-haptophore*, the other for the complement, *complementophil haptophore*. Hence amboceptors are spoken of as *receptors or haptins of the third order*. They have no other function than that of this double combining power. The action which results is due to the third body—the complement. It will be readily seen that complement must possess at least two groups a combining or *haptophore group* which unites with the amboceptor, and an active group which is usually called the *zymophore* or *toxophore group*. Complements thus resemble either toxins, where the specific cell (antigen) is injured or killed, or enzymes, in case the cell is likewise dissolved.

This action again shows the close relation between toxins and enzymes. Complement may lose its active group in the same way that toxin does and becomes then *complementoid*. Complement is readily destroyed in blood or serum by heating it to 55° to 56° for half an hour, and is also destroyed spontaneously when serum stands for a day or two, less rapidly at low temperature than at room temperature.

Amboceptors appear to be *specific* in the same sense that agglutinins are. That is, if a given cell is used to immunize an animal, the animal's blood will contain amboceptors for the cell used and also for others closely related to it. Immunization with spermatozoa or with epithelial or liver cells gives rise to amboceptors for these cells and also for red blood corpuscles and other body cells. A typhoid bactericidal serum has also some dissolving effect on colon bacilli, etc. Hence a given serum may contain a chief amboceptor and a variety of "coamboceptors," or one amboceptor made up of a number of "partial amboceptors," each specific for its own antigen ("amboceptorogen"). Amboceptors may combine with other substances than antigen and complement, as is shown by their union with lecithin and other "lipoids," though these substances seem capable of acting as complement in causing solution of blood corpuscles.

### COMPLEMENTS.

Students usually have more difficulty with complements and amboceptors than with other phases of the subject of immunity. It may help to look upon complement as an *enzyme* (or toxin) *which does not possess the power of uniting directly with the substance on which it may act*, as other enzymes do. It can be joined to this substance only by means of another and separate chemical. This latter is the amboceptor. It should be apparent that the amboceptor must be capable of uniting with the substance and also with complement it must have two uniting groups. Complement must be capable of uniting with amboceptor. It has a uniting group for amboceptor but *not* for antigen. When through the medium of this separate uniting body it is joined

to its antigen, then like an enzyme it can destroy this antigen (or act like toxin to kill it, if it is a living cell). *Complement is not an antibody.*

An illustration which may be used in the attempt to make clear to students the relation between amboceptor and complement is the following:

Agglutinin is a one molecule antibody having at least two atom complexes, a uniting group and an agglutinating group. Imagine that this molecule might be split into two separate molecules, one containing the uniting group for antigen and the other the agglutinating group. This latter cannot agglutinate by itself because it cannot unite with antigen. But if it is again united to the agglutinating group then this combination can agglutinate. If they can reunite then the molecule containing the uniting group for antigen must also have a combining group for the agglutinating molecule. This is exactly the situation with respect to amboceptor and complement, they are two separate molecules. The complement is the active molecule but cannot unite with antigen directly. The amboceptor has a uniting group for antigen and one for complement. When complement is united to amboceptor and amboceptor to antigen then complement can act on antigen. The amboceptor only is an antibody, complement is not a part of this molecule but a separate molecule and is *therefore not an antibody.*

As to whether complements are numerous, as Ehrlich claims, or there is only one complement, according to Buchner and others, need not be discussed here. In the practical applications given later as means of diagnosis it is apparent that all the complement or complements are capable of uniting with at least two kinds of amboceptors.

If complement be injected into an animal it may act as an antigen and give rise to the formation of *anticomplement*, which may combine with it and prevent its action and is consequently analogous to antitoxin. If amboceptors as antigen are injected into an animal there will be formed by the animal's cells *antiamboceptors*. As one would expect, there are two kinds of antiamboceptors, one for each of its combining groups, since it has been stated that it is always

the combining group of any given antigen that acts as the cell stimulus. Hence we may have an "anticytophil amboceptor" or an "anticomplementophil amboceptor." These antiamboceptors and the anticomplements are analogous to antitoxin, antiagglutinin, etc., and hence are receptors of the first order.

### ANTISNAKE VENOMS.

A practical use of antiamboceptors is in antislake venoms. Snake poisons appear to contain only *amboceptors* for different cells of the body. In the most deadly the amboceptor is specific for nerve cells (cobra), in others for red corpuscles, or for endothelial cells of the bloodvessels (rattlesnake). The complement is furnished by the blood of the individual bitten, that is, in a sense the individual poisons himself, since he furnishes the destroying element. The antisera contain antiamboceptors which unite with the amboceptor introduced and prevent it joining to cells and thus binding the complement to the cells and destroying them. With this exception these antibodies are chiefly of theoretical interest.

### FAILURE OF CYTOLYTIC SERUMS.

The discovery of the possibility of producing a strongly bactericidal serum in the manner above described aroused the hope that such sera would prove of great value in passive immunization and serum treatment of bacterial diseases. Unfortunately such expectations have not been realized and no serum of this character of much practical importance has been developed as yet (with the possible exception of Flexner's antimeningococcus serum in human practice. What hog cholera serum is remains to be discovered).

The reasons for the failure of such sera are not entirely clear. The following are some that have been offered: (1) Amboceptors do not appear to be present in very large amount so that relatively large injections of blood are necessary, which is not without risk in itself. (2) Since the complement is furnished by the blood of the animal to be treated, there may not be enough of this unite with a sufficient

quantity of amboceptor to destroy all the bacteria present, hence the disease is continued by those that escape. (3) Or the complement may not be of the right kind to unite with the amboceptor introduced, since this is derived from the blood of a *heterologous* ("other kind") species. In hog-cholera serum, if it is bactericidal, this difficulty is removed by using blood of a *homologous* ("same kind") animal. Hence, Ehrlich suggested the use of apes for preparing bactericidal sera for human beings. The good results which have been reported in the treatment of human beings with the serum of persons convalescing from the same disease indicate that this lack of proper complement for the given amboceptor is probably a chief factor in the failure of sera from lower animals. (4) The bacteria may be localized in tissues (lymph glands), within cavities (cranial, peritoneal), in hollow organs (alimentary tract), etc., so that it is not possible to get at them with sufficient serum to destroy all. This difficulty is obviated by injecting directly into the spinal canal when Flexner's antimeningococcus serum is used. (5) Even if the bacteria are dissolved it does not necessarily follow that their *endotoxins* are destroyed. These may be merely liberated and add to the danger of the patient, though this does not appear to be a valid objection. (6) Complement which is present in such a large excess of amboceptor may just as well unite with amboceptor which is not united to the bacteria to be destroyed as with that which is, and hence be actually prevented from dissolving the bacteria. Therefore it is difficult to standardize the serum to get a proper amount of amboceptor for the complement present.

### COMPLEMENT-FIXATION TEST.

Although little practical use has been made of bactericidal sera, the discovery of receptors of this class and the peculiar relations between the antigen, amboceptor and complement have resulted in developing one of the most delicate and accurate methods for the diagnosis of disease and for the

recognition of small amounts of specific protein that is in use today.

This method is usually spoken of as the "complement-fixation test" ("Wassermann test" in syphilis) and is applicable in a great variety of microbial diseases; but it is of practical importance in those diseases only where other methods are uncertain—syphilis in man, concealed glanders in horses, contagious abortion in cattle, etc. A better name would be the "Unknown Amboceptor Test," since it is the amboceptor that is searched for in the test by making use of its power to "fix" complement.

The principle is the same in all cases. The method depends, as indicated above, on the ability of complement to combine with at least two amboceptor-antigen systems, and on the further fact that if the combination with one amboceptor-antigen system is once formed, it does not dissociate so as to liberate the complement for union with the second amboceptor-antigen system. If an animal is infected with a microorganism and a part of its defensive action consists in destroying the organisms in its blood or lymph, then it follows from the above discussion of cytolytins that there will be developed in the blood of the animal amboceptor specific for the organism in question. If the presence of this *specific amboceptor* can be detected, the conclusion is warranted that the organism for which it is specific is the cause of the disease. Consequently what is sought in the "complement-fixation test" is a *specific amboceptor*. In carrying out the test, blood serum from the suspected animal is collected, heated at 56° for half an hour to destroy any complement it contains and mixed in definite proportions with the specific antigen and with complement. The antigen is an extract of a diseased organ (syphilitic fetal liver in syphilis), a suspension of the known bacteria, or an extract of these bacteria. Complement is usually derived from a guinea-pig, since the serum of this animal is higher in complement than that of most animals. The blood of the gray rat contains practically as much. If the specific amboceptor is present, that is, if the animal is infected with the suspected disease, the complement will

unite with the antigen-amboceptor system and be "fixed," that is, be no longer capable of uniting with any other amboceptor-antigen system. No chemical or physical means of telling whether this union has occurred or not, except as given below, has been discovered as yet, though doubtless will be by physico-chemical tests, nor can the combination be seen. Hence an "indicator," as is so frequently used in chemistry, is put into the mixture of antigen-amboceptor-complement after it has been allowed to stand in the incubator for one-half to one hour to permit the union to become complete. The "indicator" used is a mixture of sheep's corpuscles and the heated ("inactivated") blood serum of a rabbit which has been injected with sheep's blood corpuscles and therefore contains a *hemolytic amboceptor specific* for the corpuscles which is capable also of uniting with complement. The indicator is put into the first mixture and the whole is again incubated and examined. If the mixture is *clear* and *colorless* with a *deposit of red corpuscles* at the bottom, that would mean that the complement had been bound to the first complex, since it was not free to unite with the second sheep's corpuscles (antigen)—rabbit serum (hemolytic amboceptor) complex—and destroy the corpuscles. Hence if the complement is bound in the first instance, the *specific amboceptor* for the first antigen must have been present in the blood, that is, the animal was infected with the organism in question. Such a reaction is called a "positive" test.

On the other hand, if the final solution is *clear* but of a *red* color, that would mean that complement must have united with the corpuscles—hemolytic amboceptor system—and destroyed the corpuscles in order to cause the *clear red* solution of hemoglobin. If complement united with this system it could not have united with the first system, hence there was no *specific amboceptor* there to bind it; no specific amboceptor in the animal's blood means no infection. Hence a *red solution* is a "negative test."

The scheme for the test may be outlined as follows:

Antigen	+	Patient's serum, heated	+	Complement
(specific for the		(unknown amboceptor)		(derived from
amboceptor sought)				guinea-pig's serum)

Incubate one-half hour in a water-bath or one hour in an incubator.

Then add the indicator which is—

Antigen	+	Amboceptor
(red blood corpuscles)		(for corpuscles, serum of a rabbit immunized against the red corpuscles)

Incubate as above.

In practice all the different ingredients must be accurately tested, standardized and used in exact quantities, and tests must also be run as controls with a known normal blood of an animal of the same species as the one examined and with a known positive blood.

It should be stated that in one variety of the Complement-fixation Test, namely, the "Wassermann Test for Syphilis" in human beings, an antigen is used which is not derived from the specific organism (*Treponema pallidum*) which causes the disease nor even from syphilitic tissue. It has been determined that alcohol will extract from certain tissues, *human* or *animal*, substances which *act specifically* in combining with the syphilitic amboceptor present in the blood. Alcoholic extracts of beef heart are most commonly used. Details of this test may be learned in the advanced course in Immunity and Serum Therapy.

The actual making of a complement-fixation test can be learned only by repeated practise in the laboratory. It should not be difficult for the student to understand the theory of the test without actually doing it. It is the application of principles he should have learned in his freshman chemistry. It is a test to find an *unknown chemical substance*. The substance sought is an amboceptor. The student knows that in testing for an unknown chemical in solution one adds to the solution other chemicals with which the unknown *will react*. Amboceptors react with their specific antigens and with complement. Hence to the patient's serum, which is being tested for the unknown amboceptor, are added a solution of the specific antigen and some guinea-pig's serum which contains complement. These three substances *will give no reaction which can be detected by any known means*. It is another principle known to the student that in such cases it is customary to add some other substance which *will show a reaction* with some of the



original ingredients. This latter substance is called an *indicator*. Without discussing the theory of indicators, it will be sufficient to point out that they are usually substances which will show a *visible change* in the presence of an *excess* of one of the reagents. In this case the excess, if any, will be *complement*. The indicator must react with complement. Therefore it must contain *antigen* and its specific *amboceptor*. The antigen and amboceptor which will actually show a change when antigen is acted on by complement are *red blood corpuscles* for antigen and amboceptor contained in the serum of an animal immunized against these same red corpuscles. Red corpuscles in suspension in physiological normal salt solution give a *reddish, opaque fluid*. If the red corpuscles are destroyed by complement, the hemoglobin will go into solution and the reddish, opaque fluid will change to a *clear, transparent, red colored fluid*. If corpuscles are not destroyed, they will in a few hours settle to the bottom of the tube as a reddish deposit.

Complement can not be in excess if there is amboceptor in the original mixture. The indicator will show no change. The unknown amboceptor has been found to be present. Hence the test is *positive*. If the corpuscles are destroyed a red solution will result and complement must have been free to unite with the second amboceptor. If free, it did not unite with the amboceptor in the first mixture *because there was none present*. No amboceptor, no disease. Hence a clear red solution is a *negative test*.

The complement-fixation test might be applied to the determination of unknown bacteria, using the unknown culture as antigen and trying it with the sera of different animals immunized against a variety of organisms, some one of which might prove to furnish *specific amboceptor* for the unknown organism and hence indicate what it is. The test used in this way has not been shown to be a practical necessity and hence is rarely employed. It has been used, however, to detect traces of unknown proteins, particularly blood-serum proteins, in medico-legal cases in exactly the above outlined manner, and is very delicate and accurate.

**BACTERIOPHAGE.**

Twort<sup>1</sup> in 1915 described certain cultures of a micrococcus on agar slants which showed areas of transformation into transparent glassy-looking spots. For this apparent lysis Twort proposed various explanations none of them satisfactory even to himself. D'Herelle 1917 and since has reported similar phenomena of the clearing of large or small areas on surface growths and also the clearing of broth cultures. This phenomenon has become known as the "Twort-D'Herelle phenomenon." D'Herelle has pursued investigations along this line most extensively.<sup>2</sup> He finds this lytic substance frequently present in the intestinal tract of man and animals recovered from or immune to various infections. It is not specific but acts on different kinds of bacteria, usually more vigorously on some than on others. Some strains are not affected. D'Herelle showed that a small portion, a drop, of fluid containing the principle will bring about solution of an entire broth culture; a drop from this will dissolve a second; from this a drop will dissolve a third and so on indefinitely. *It appears to grow in the cultures along with the bacteria.* It will not grow on dead bacteria. D'Herelle concludes that these phenomena are due to an *ultramicroscopic parasite, a virus that grows only on living bacteria.* He has named this virus *Bacteriophagum intestinale* or *bacteriophage*. He is of the opinion that it plays a most important part in recovery from many infectious diseases and in immunity from them. As to the facts of lysis of bacteria as described by D'Herelle there is no dispute. Numerous workers have duplicated his results. Not all agree with him in interpreting the phenomena as due to a living parasite of bacteria or that the bacteriophage is of such importance in immunity. The apparent growth of the "principle" might be explained as due to continued production of it by the growing bacteria. Final decision as to the nature of the bacteriophage must await further research.

<sup>1</sup> "An Investigation of the Nature of Ultramicroscopic Viruses," *Lancet*, 1915, ii, 1241.

<sup>2</sup> *The Bacteriophage* by F. D'Herelle, English translation by George H. Smith, 1922. *Immunity in Natural Infectious Disease* by F. D'Herelle, English translation by George H. Smith, 1924.

## CHAPTER XXX.

### PHAGOCYTOSIS—OPSONINS.

It has been mentioned that Metchnikoff, in a publication in 1883, attempted to explain immunity on a purely cellular basis. It has been known since Haeckel's first observation in 1858 that certain of the white corpuscles do engulf solid particles that may get into the body, and among them bacteria. Metchnikoff at first thought that this engulfing and subsequent intracellular digestion of the microorganisms were sufficient to protect the body from infection. The later discoveries (discussed in considering Ehrlich's theory of immunity) of substances present in the blood serum and even in the blood plasma which either destroy the bacteria or neutralize their action have caused Metchnikoff to modify his theory to a great extent. He admitted the presence of these substances, though giving them other names, but ascribed their formation to the phagocytes or to the same organs which form the leukocytes—lymphoid tissue generally, bone-marrow. It is not within the province of this work to attempt to reconcile these theories, but it may be well to point out that Ehrlich's theory is one of *chemical substances* and that the *origin* of these substances is not an *essential* part of the theory, so that the two theories, except in some minor details, are not necessarily mutually exclusive.

Sir A. E. Wright and Douglas, in 1903, showed that even in those instances where immunity depends on phagocytosis, as it certainly does in many cases, the phagocytes are more or less inactive unless they are aided by chemical substances present in the blood. These substances *act on the bacteria not on the leukocytes*, and change them in such a way that they are more readily taken up by the phagocytes. Wright

proposed for these bodies the name *opsonin*, derived from a Greek word signifying "to prepare a meal for." Neufeld and Rimpau at about the same time (1904), in studying immune sera, observed substances of similar action in these sera and proposed the name *bacteriotropins*, or bacteriotropic substances. There is scarcely a doubt that the two names are applied to identical substances and that Wright's name *opsonin* should have preference.

The chemical nature of opsonins is not certainly determined, but they appear to be a distinct class of antibodies and to possess two groups, a combining or haptophore and a preparing or opsonic group, and hence are similar to antibodies of Ehrlich's second order—agglutinins and precipitins. Wright also showed that opsonins are just as specific as agglutinins are—that is, a staphylococcus opsonin prepares staphylococci only for phagocytosis and not streptococci or any other bacteria.

Wright showed that opsonins for many bacteria are present in normal serum and that in the serum of an animal which has been immunized against such bacteria the opsonins are *increased* in amount. Also that in a person infected with certain bacteria the opsonins are either increased or diminished, depending on whether the progress of the infection is favorable or unfavorable. The *opsonic power* of a serum normal or otherwise is determined by mixing a suspension of fresh leukocytes in normal saline solution with a suspension of the bacteria and with the serum to be tested. The leukocytes must first be washed in several changes of normal salt solution to free them from any adherent plasma or serum. The mixture is incubated for about fifteen minutes and then slides are made, stained with a good differential blood stain, Wright's or other, and the average number of bacteria taken up by at least fifty phagocytes taken in order in a field is determined by counting under the microscope. The number so obtained Wright calls the *phagocytic index* of the serum tested. The phagocytic index of a given serum divided by the phagocytic index of a normal serum gives the *opsonic index* of the serum tested. Assuming the normal opsonic index to be 1, Wright

asserts that in healthy individuals the range should be not more than from 0.8 to 1.2, and that an index below 0.8 may show a great susceptibility for the organism tested, infection with the given organism if derived from the individual, or improper dosage in case attempts have been made to immunize by using killed cultures, vaccines, of the organism.

On the occasion of the author's visit to Wright's clinic (1911) he stated that he used the determination of the *opsonic index* chiefly as a *guide to the dosage* in the use of vaccines.

Most workers outside the Wright school have failed to recognize any essential value of determinations of the opsonic index in the use of vaccines. Some of the reasons for this are as follows: The limit of error in phagocytic counts may be as great as 50 per cent in different series of fifty, hence several hundred must be counted, which adds greatly to the tediousness and time involved; the variation in apparently healthy individuals is frequently great, hence the "normal" is too uncertain; finally the opsonic index and the clinical course of the disease do not by any means run parallel. Undoubtedly the method has decided value in the hands of an individual who makes opsonic determinations his chief work, as Wright's assistants do, but it can scarcely be maintained at the present time that such determinations are necessary in vaccine therapy. Nevertheless that opsonins actually exist and that they play an essential part in phagocytosis, and hence in immunity, is now generally recognized.

### BACTERIAL VACCINES.

Whether determinations of opsonic index are useful or not is largely a matter of individual opinion, but there is scarcely room to doubt that Wright has conferred a lasting benefit by his revival of the use of *dead cultures of bacteria*, *bacterial vaccines*, both for protective inoculation and for treatment. It is perhaps better to use the older terms "vaccination" and "vaccine" (though the cow, *vacca*, is not concerned) than to use Wright's term "opsonic method"

in this connection, bearing in mind that the idea of a vaccine is that it contains the *causative organism* of the infection, as indicated on page 249.

As early as 1880 Touissant proposed the use of dead cultures of bacteria to produce immunity. But because injections of such cultures were so frequently followed by abscess formation, doubtless due to the *high temperatures* used to kill the bacteria, the method was abandoned. Further, Pasteur and the French school persistently denied the possibility of success with such a procedure, and some of them even maintain this attitude at the present time. The successes of Wright and the English school which are being repeated so generally wherever properly attempted, leave no doubt in the unprejudiced of the very great value of the method and have unquestionably opened a most promising field both for preventive inoculation and for treatment in many infectious diseases. That the practice is no more universally applicable than are immune serums, and that it has been and is still being grossly overexploited, is undoubted.

The use of a vaccine is based on two fundamental principles. The first of these is that the cell introduced must not be in a condition to cause serious injury to the animal by its multiplication and consequent elaboration of injurious substances. The second is that, on the other hand, it must contain antigens in such condition that they will act as stimuli to the body cells to produce the necessary antibodies, whether these be opsonins, bactericidal substances or antiendotoxins. In the introduction of living organisms there is always more or less risk of the organisms not being sufficiently attenuated and hence of the possibility of its producing too severe an infection. In using killed cultures, great care must be exercised in destroying the organisms, *so that the antigens are not at the same time rendered inactive*. Hence in the preparation of bacterial vaccines by Wright's method the *temperature and the length of time used to kill the bacteria are most important factors*. This method is in general to grow the organisms on an agar medium, rub off the culture and suspend in sterile normal salt solution (0.85

per cent NaCl). The number of bacteria per cc is determined by staining a slide made from a small volume of the emulsion mixed with an equal volume of human blood drawn from the finger and counting the relative number of bacteria and of red blood corpuscles. Since the corpuscles are normally 5,000,000 per c.mm., a simple calculation gives the number of bacteria. The emulsion of bacteria is then diluted so that a certain number of millions shall be contained in each cc, "standardized" as it is called, then heated to the proper temperature for the necessary time and it is ready for use. A preservative, as 0.5 per cent phenol, tricresol, etc., is added unless the vaccine is to be used up at once. The amounts of culture, salt solution, etc., vary with the purpose for which the vaccine is to be used, from one or two agar slant cultures and a few cc of solution, when a single animal is to be treated, to bulk agar cultures and liters of solution as in preparing antityphoid vaccine on a large scale.

Agar surface cultures are used so that there will be as little admixture of foreign protein as possible (see Anaphylaxis, page 288 *et seq.*). Normal saline solution is isotonic with the body cells and hence is employed as the vehicle.

**Lipovaccines.**—The suspension of bacteria in neutral oil was first used by Le Moignac and Pinoy, who gave the name "lipovaccines" ( $\lambda\iota\pi\omicron\varsigma$ , lipos = fat) to them. It was claimed that the reaction following injection of these vaccines was less severe than with saline vaccines in many instances; also, that the bacteria were much more slowly absorbed. For these two reasons it was hoped that much larger numbers of bacteria could be injected at one dose and one injection would suffice instead of three or more as ordinarily used. The technic of preparation, standardization and killing of the organisms has not as yet been sufficiently well established to warrant the general substitution of lipovaccines for ordinary saline suspensions.

Vaccines are either "autogenous" or "stock." An "autogenous" vaccine is a vaccine that is made from bacteria derived from the individual or animal which it is desired to vaccinate and contains not only the particular organism but

the particular strain of that organism which is responsible for the lesion. Stock vaccines are made up from organisms like the infective agent in a given case but derived from some other person or animal or from laboratory cultures. Commercial vaccines are "stock" vaccines and are usually "polyvalent" or even "mixed." A "polyvalent" vaccine contains several strains of the infective agent and a "mixed" contains several different organisms.

Stock vaccines have shown their value when used as preventive inoculations, notably so in typhoid fever in man, anthrax and black-leg in cattle. The author is strongly of the opinion, not only from the extended literature on the subject, but also from his own experience in animals, and especially in human cases, that stock vaccines are much inferior and much more uncertain in their action when used in the *treatment* of an infection than are autogenous vaccines. This applies particularly to those instances in which *pneumococci*, *streptococci*, *staphylococci* and *colon bacilli* are the causative agents, but to others as well. The following are some of the reasons for this opinion: The above organisms are notoriously extremely variable in their virulence. While there is no necessarily close connection between virulence and antigenic property, yet since virulence is so variable it is rational to assume that antigenic property is also extremely variable. Individuals vary just as much in susceptibility, and hence in reactive power, and, generally speaking, an individual will react better in the production of antibodies to a stimulus to which he has been more or less subjected, *i. e.*, to organisms derived from his own body.

In the preparation of a vaccine great care must be used in heating so that the organisms are killed, but the *antigens* are not destroyed. Many of the enzymes present in bacteria, especially the proteolytic ones, are not any more sensitive to heat than are the antigens, hence are not destroyed entirely. Therefore a vaccine kept in stock for a long time gradually has some of its antigens destroyed by the uninjured enzymes present with them, and so loses in potency. Therefore in treating a given infection it is well to make up a



vaccine from the lesion, use three or four doses and if more are necessarily make up a new vaccine.

If the above statements are borne in mind and vaccines are made and administered accordingly the author is well satisfied that much better results will be secured.

In accordance with the theory on which the use of vaccines is based, *i. e.*, that they stimulate the body cells to produce immunizing antibodies, it is clear that they are especially suitable in those infections in which the process is *localized* and should not be of much value in *general* infections. In the latter case the cells of the body are stimulated to produce antibodies by the circulating organisms, probably nearly to their limit, hence the introduction of more of the same organisms, capable of stimulating though dead, is apt to overtax the cells and do more harm than good. It is not possible to tell accurately when this limit is reached, but the clinical symptoms are a guide. If vaccines are used at all in general infections they should be given in the early stages and in small doses at first, with close watch as to the effect. In localized infections only the cells in the immediate neighborhood are much stimulated, hence the introduction of a vaccine calls to their aid cells in the body generally, and much more of the resulting antibodies are carried to the lesion in question. Manifestly surgical procedures such as incision, drainage, washing away of dead and necrotic tissue with normal saline solution, not necessarily antiseptics, will aid the antibodies in their action and are to be recommended where indicated.

In the practical application of any remedy the *dosage* is most important. Unfortunately there is no accurate method of determining this with a vaccine. Wright recommended determining the number of the organisms per cc as before mentioned, and his method or some modification of it is still in general use. From what was said with regard to variation, both in organisms and in individuals, it can be seen that the number of organisms is at least only a very rough guide. This is further illustrated by the doses of staphylococcus vaccines recommended by different writers, which vary from 50,000,000 to 2,000,000,000 per cc. The

author is decidedly of the opinion that *there is no way of determining the dosage of a vaccine in the treatment of any given case except by the result of the first dose.* Hence it is his practice to make vaccines of a particular organism of the same approximate strength, and to give a dose of a measured portion of a cubic centimeter, judging the amount by what the individual or animal can apparently withstand, without too violent a reaction. If there is no local or general reaction, or if it is very slight and there is no effect on the lesion, the dose is too small. If there is a violent local reaction with severe constitutional symptoms clinically, and the lesion appears worse, the dose is too large. There should be some local reaction and some general, but not enough to cause more than a slight disturbance, easy to judge in human subjects, more difficult in animals. In cases suitable for vaccine treatment no *serious* results should follow from a properly prepared vaccine, though the process of healing may be delayed temporarily. Wright claimed, and many have substantiated him, that always following a vaccination there is a period when the resistance of the animal is diminished. This is called the "negative phase," and Wright considered this to last as long as the opsonic index remained low, and when this latter began to increase the stage of the "positive" or favorable phase was reached. As has been stated the opsonic index is pretty generally regarded as of doubtful value, though the existence of a period of lowered resistance is theoretically probable from the fact that antibodies already present in the blood will be partially used up in uniting with the vaccine introduced and that the body cells are called upon suddenly to do an extra amount of work, and it takes them some time to adapt themselves. This time the "negative phase" is much better determined by the clinical symptoms, general and especially local. It is good practice to begin with a dose relatively small. The result of this is an indication of the proper dosage and also prepares the patient for a larger one. The second dose should follow the first not sooner than three or four days, and should be five to seven days if the first reaction is severe.

These directions are not very definite, but clinical experience to date justifies them. It is worth the time and money to one who wishes to use vaccines to learn from one who has had experience both in making and administering them, and then to remember that each patient is an individual case for the use of vaccines as well as for any other kind of treatment.

### AGGRESSINS.

Opsonins have been shown to be specific substances which act on bacteria in such a way as to render them more readily taken up by the leukocytes. By analogy one might expect to find bacteria secreting specific substances which would tend to counteract the destructive action of the phagocytes and bactericidal substances. Bail and his co-workers claim to have demonstrated such substances in exudates in certain diseases and have given the distinctive name "aggressins" to them. By injecting an animal with "aggressins," anti-aggressins are produced which counteract their effects and thus enable the bacteria to be destroyed. The existence of such specific bodies is not generally accepted as proved. The prevailing idea is that bacteria protect themselves in any given case by the various toxic substances that they produce, and that "aggressins" as a special class of substances are not formed.

## CHAPTER XXXI.

### ANAPHYLAXIS.

DALLERA, in 1874, and a number of physiologists of that period, observed peculiar skin eruptions following the transfusion of blood, that is, the introduction of foreign proteins. In the years subsequent to the introduction of diphtheria antitoxin (1890) characteristic "serum rashes" were not infrequently reported, sometimes accompanied by more or less severe general symptoms and occasionally death—a train of phenomena to which the name "serum sickness" was later applied, since it was shown that it was the horse serum (foreign protein) that was the cause and not the antitoxin itself. In 1898, Richet and Hericourt noticed that some of the dogs which they were attempting to immunize against toxic eel serum not only were not immunized but suffered even more severely after the second injection. They obtained similar results with an extract of muscles which contain a toxin. Richet gave the name "anaphylaxis" ("no protection") to this phenomenon to distinguish it from immunity or prophylaxis (protection).

All the above-mentioned observations led to no special investigations as to their cause. In 1903, Arthus noticed abscess formation, necrosis and sloughing following several injections of horse serum in immediately adjacent parts of the skin in rabbits ("Arthus's phenomenon"). Theobald Smith, in 1904, observed the death of guinea-pigs following properly spaced injections of horse serum. This subject was investigated by Otto and by Rosenau and Anderson in this country and about the same time von Pirquet and Schick were making a study of serum rashes mentioned above. The publications of these men led to a widespread study of the subject of injections of foreign proteins. It is now a well-

established fact that the injection into an animal of a foreign protein—vegetable, animal or bacterial, simple or complex—followed by a second injection after a proper length of time leads to a series of symptoms indicating poisoning which may be so severe as to cause the death of the animal. Richet's term "anaphylaxis" has been applied to the condition of the animal following the first injection and indicates that it is in a condition of supersensitiveness for the protein in question. The animal is said to be "sensitized" for that protein.<sup>1</sup> The sensitization is specific since an animal injected with white of chicken's egg reacts to a second injection of chicken's egg only and not pigeon's egg or blood serum or any other protein. The specific poisonous substance causing the symptoms has been called "anaphylo-toxin," though what it is is still a matter of investigation. It is evident that some sort of an antibody results from the first protein injected and that it is specific for its own antigen.

A period of ten days is usually the minimum time that must elapse between the first and second injections in guinea-pigs in order that a reaction may result, though a large primary dose requires much longer. If the second injection is made within less time no effect follows, and after three or more injections, at intervals of about one week, the animal fails to react at all it has become "immune" to the protein. Furthermore, after an animal has been sensitized by one injection and has reacted to a second, then if it does not die from the reaction it fails to react to subsequent injections. In this latter case it is said to be "antianaphylactic."

It must be remembered that proteins do not normally get into the circulation except by way of the alimentary tract. Here all proteins that are absorbed are first broken down to their constituent amino-acids, absorbed as such, and these are built up into the proteins characteristic of the animal's blood. Hence when protein as such gets into the blood it is a foreign substance to be disposed of. The blood

<sup>1</sup> The term "allergie" was introduced by von Pirquet to designate the state of the animal's being sensitized and "allergic," as the adjective derived therefrom. *Allergy* is quite generally used to indicate the condition of natural sensitization, *anaphylaxis* that of artificial.

contains proteolytic enzymes for certain proteins normally. It is also true that the body cells possess the property of digesting the proteins of the blood and building them up again into those which are characteristic of the cell. Hence it appears rational to assume that the foreign proteins act as stimuli to certain cells to produce more of the enzymes necessary to decompose them, so that they may be either built up into cell structure or eliminated as waste. If in this process of splitting up of protein a poison were produced, then the phenomena of "anaphylaxis" could be better understood. As a matter of fact, Vaughan and his co-workers have shown that by artificially splitting up proteins from many different sources—animal, vegetable, pathogenic and saprophytic bacteria—a poison *is produced* which appears to be the same in all cases and which causes the symptoms characteristic of anaphylaxis. On the basis of these facts it is seen that anaphylaxis is simply another variety of immunity. The *specific antibody* in this case is an *enzyme* which decomposes the protein instead of precipitating it. The enzyme must be specific for the protein, since these differ in constitution. Vaughan even goes so far as to say that the poison is really the central ring common to all proteins and that they differ only in the lateral groups or side chains attached to this central nucleus. The action of the enzyme in this connection would be to split off the side chains, and since these are the specific parts of the protein the enzyme must be specific for each protein. The pepsin of the gastric juice and the trypsin of the pancreas split the native proteins only to peptones. As is well known, these when injected in sufficient quantity give rise to poisonous symptoms, and will also give rise to anaphylaxis under properly spaced injections. They do not poison normally because they are split by the intestinal erepsin to amino-acids and absorbed as such. Whether Vaughan's theory of protein structure is the true one or not remains to be demonstrated. It is not essential to the theory of anaphylaxis above outlined, *i. e.*, a phenomenon due to the action of specific *antibodies* which are enzymes. On physiological grounds this appears the most rational of the few explanations of anaphylaxis that have been offered and was

taught by the author before he had read Vaughan's theory along the same lines.

On the basis of the author's theory the phenomena of protein immunity and antianaphylaxis may be explained in the following way, which the author has not seen presented: The enzymes necessary to decompose the injected protein are present in certain cells and are formed in larger amount by those cells to meet the increased demand due to injection of an excess of protein. They are retained in the cell for a time at least. If a second dose of protein is given before the enzymes are excreted from the cells as waste, this is digested within the cells in the normal manner. If a third dose is given the cells adapt themselves to this increased intracellular digestion, and it thus becomes normal to them. Hence the *immunity* is due to this increased intracellular digestion.

On the other hand, if the second injection is delayed long enough, then the *excess* enzyme, but not all, is excreted from the cells and meets the second dose of protein in the blood stream and rapidly decomposes it there, so that more or less intoxication from the split products results. This uses up *excess* enzyme, hence subsequent injections are not digested in the blood stream but within the cells as before. So that "antianaphylaxis" is dependent on the exhaustion of the *excess* enzyme in the blood, and the condition is *fundamentally* the same as protein immunity, *i. e.*, due to *intracellular* digestion in each case.

Since complement is used up in anaphylactic shock it may be that the antibody produced is an *amboceptor* which with complement splits the protein introduced and liberates a poison. Or the using up of complement may be merely incidental. A really satisfactory theory of anaphylactic shock remains to be brought forward.

As has been indicated, "serum sickness" and sudden death following serum injections are probably due to a sensitization of the individual to the proteins of the horse in some unknown way. Hay fever, urticarial rashes and idiosyncrasies following the ingestion of certain foods, as strawberries, eggs, oysters, etc., are in most cases anaphylactic phenomena.

The proper procedure to obtain relief in such cases is to

*determine the cause* and then to immunize against it. If an individual knows that eggs, for example, are the cause, the remedy would be to eat a minute amount of egg that will not cause the disturbance and to continue each day to increase the amount gradually until immunity is established.

In many cases of hay fever it is difficult to determine the cause, in many others it is not. The procedure in such cases is to apply the "skin test," intracutaneous injection of minute quantities of the materials suspected. A local reaction will indicate the cause. If this is determined a course of injections of solutions of the causative agent taken before the time when the "hay fever" usually appears will in many cases give relief. Test solutions and immunizing solutions of a great number of known causative agents may be procured from commercial sources. Various pollens are a common, but by no means the only cause.

The author knows from his own experience that organisms in the nose are frequently associated with these conditions. Vaccines made from these organisms have in his hands relieved many.

The proper procedure, however, is, as above outlined, *to ascertain the cause and then to immunize against it.*

In medical practice the reaction is used as a means of diagnosis in certain diseases, such as the tuberculin test in tuberculosis, the mallein test in glanders. The individual or animal with tuberculosis becomes sensitized to certain proteins of the tubercle bacillus, and when these proteins in the form of tuberculin are introduced into the body a reaction results, local or general, according to the method of introduction. The practical facts in connection with the tuberculin test are also in harmony with the author's theory of anaphylaxis as above outlined. Milder cases of tuberculosis give more vigorous reactions because the intracellular enzymes are not used up rapidly enough since the products of the bacillus are secreted slowly in such cases. Hence excess of enzyme is free in the blood and the injection of the tuberculin meets it there and a vigorous reaction results. In old, far-advanced cases no reaction occurs, because the enzymes are all used in decomposing the large amount of tuberculous protein constantly present in the



blood. The fact that an animal which has once reacted fails to do so until several months afterward likewise depends on the fact that the *excess* enzyme is used in the reaction and time must elapse for a further excess to accumulate.

The anaphylactic reaction has been made use of in the identification of various types of proteins and is of very great value, since the reaction is so delicate, particularly when guinea-pigs are used as test animals. Wells has detected the 0.000001 g. of protein by this test. It is evident that the test is applicable in medico-legal cases and in food examination and has been so used.

#### A TABULATION OF ANTIGENS AND ANTIBODIES AS AT PRESENT RECOGNIZED.

ANTIGEN.	ANTIBODY.	ACTION OF ANTIBODY.	CLASS OF RECEPTOR.
Toxin	Antitoxin	Combines with toxin and hence prevents toxin from uniting with a cell and injuring it, <i>i. e.</i> , neutralizes toxin.	I.
Enzyme	Antienzyme	Combines with enzyme and thus prevents enzyme from uniting with anything else and showing its action, <i>i. e.</i> , neutralizes enzyme.	I.
Solution of protein	Precipitin	Unites with its antigen and causes its precipitation from solution.	II.
Solution of protein	?	Causes phenomenon of anaphylaxis(?)	(?)
Suspension of cells	Agglutinin	Unites with its antigen and causes its clumping together and settling out of suspension.	II.
Suspension of cells	Opsonin	Unites with its antigen and makes the cells more easily taken up by phagocytes.	II(?)
Suspension of cells	Amboceptor	Unites with its antigen and also with complement which latter then dissolves the antigen.	III.
Precipitin	Antiprecipitin	Neutralizes precipitin.	I.
Agglutinin	Antiagglutinin	Neutralizes agglutinin.	I.
Opsonin	Antiopsonin	Neutralizes opsonin.	I.
Amboceptor	Antiamboceptor (two kinds)	Neutralizes amboceptor.	I.
Complement	Anticomplement	Neutralizes complement.	I.

SUMMARY OF IMMUNITY AS APPLIED TO PROTECTION  
FROM DISEASE.

The discussion of "immunity problems" in the preceding chapters serves to show that protection from disease either as a condition natural to the animal or as an acquired state is dependent on certain properties of its body cells or fluids, or both. The actual factors so far as at present known may be summarized as follows:

1. *Antitoxins* which neutralize true toxins; shown to exist for very few diseases.

2. *Cytolytic substances* which destroy the invading organism: in reality two substances; amboceptor, which is specific, and complement, the real dissolving enzyme.

3. *Phagocytosis* or the destruction of the invading organisms within the leukocytes.

4. *Opsonins* which render the bacteria more readily taken up by the phagocytes.

5. *Enzymes* other than complement possibly play a part in the destruction of some pathogenic organisms or their products. This remains to be more definitely established.

6. It is possible that in natural immunity there might be no receptors in the body cells to take up the organisms or their products, or the receptors might be present in certain cells but of a very low chemical affinity, so that combination does not occur. It is even highly probable that many substances formed by invading organisms which might injure specialized cells, such as those of glandular, nervous or muscle tissue, have a more rapid rate of reaction with, or a stronger affinity for, lower unspecialized cells, such as connective and lymphoid tissue, and unite with these so that their effects are not noticed.

The importance of these different factors varies in different diseases and need not be considered in this connection.

The question "which of the body cells are engaged in the production of antibodies" is not uncommonly asked. On physiological grounds it would not seem reasonable that the highly specialized tissues above mentioned could take up

this work, even though they are the ones which suffer the greatest injury in disease. Hence it is to be expected that the lower or unspecialized cells are the source, and it has been shown that the antibodies are produced by the phagocytes (though not entirely as Metchnikoff maintained), by lymphoid tissue generally, by the bone-marrow and also by connective-tissue cells, though in varying degrees.

Since immunity depends on the activity of the body cells, it is evident that one of the very best methods for avoiding infectious diseases is to keep these cells up to their highest state of efficiency to keep in "good health." Hence good health means not only *freedom from disease* but also *protection against disease*.

## CHAPTER XXXII.

### A BRIEF HISTORY OF BACTERIOLOGY UP TO 1881.

BACTERIOLOGY as a science is a development of the latter half of the nineteenth century. Pasteur's epoch-making work on fermentation in the fifties, on a silk worm disease (protozoan) in 1865, on "diseases" of wine and their prevention by "pasteurization," 1860-1865 were laying a firm foundation. Lister's antiseptis, 1867, Koch's (1876) and Pasteur's (1877) proof that bacteria cause anthrax, Koch's (1878) discovery that wound infections are due to microorganisms were important mile stones. The main reasons for the *sudden and world-wide interest* in bacteriology in the early eighties were certain important methods which made it comparatively easy to study bacteria. These were the introduction of anilin dyes for staining by Weigert in 1877, the great improvements in the microscope by Abbé and the adaptation of gelatin plates for isolating bacteria in pure culture by Koch in 1881.

However as in all sciences what one can call preliminary work had been going on for about two hundred years in the course of which some of the fundamental principles of bacteriological study were established. The chronological table at the end of this section indicates that isolated observations in different lines probably had their effects on other lines. For the purpose of discussion these fields must be considered separately. They are: I. **Spontaneous Generation.** II. **Causation of Disease.** III. **Putrefaction and Fermentation.** IV. **The Study of Forms.**

#### SPONTANEOUS GENERATION.

Speculation as to the first origin of life is as old as history and doubtless older. Every people of antiquity has its own

PLATE IV



ANTHONY VON LEEUWENHOEK

Who first saw bacteria



legends, as, for example, the account in Genesis. This question never can be definitely settled, even though living matter should be made in the laboratory.

The doctrine of the "spontaneous origin" of particular animals or plants from dead material under man's own observation is a somewhat different proposition and may be subjected to experimental test. The old Greek philosophers believed it. Anaximander (B. C. 610-547) taught that some animals are derived from moisture. Even Aristotle (B. C. 384-322) said that "animals sometimes arise in soil, in plants or in other animals," *i. e.*, spontaneously. It can be stated that this belief was general from his day down through the Dark and Middle Ages and later. Cardano (A. D. 1501-1576) wrote that water gives rise to fish and animals and is also the cause of fermentation. Van Helmont (1578-1644) gives directions for making artificial mice. Kircher (1602-1680) describes and figures animals *produced under his own eyes* by water on plant stems.

However, many thinkers of the seventeenth century doubted the truth of this long-established belief. Francesco Redi (1626-1698) made a number of experiments which tended to prove that maggots did not arise spontaneously in meat, as was generally believed, but developed only when flies had an opportunity to deposit their eggs on the meat. It seems that by the latter part of this century the idea that organisms large enough to be seen with the naked eye could originate spontaneously was generally abandoned by learned men.

The work of Leeuwenhoek served to suspend for a time the subject of spontaneous generation, only to have it revived more vigorously later on. He is usually called "The Father of the Microscope," though the compound microscope was invented probably by Hans Zanzs or his son Zacharias, of Holland, about 1590. Leeuwenhoek used a simple lens, but his instruments were so much more powerful that they opened up an entirely new and unknown world (Fig. 169).

Anthony van Leeuwenhoek (1632-1723) was apprenticed to a linen draper and accumulated a comfortable fortune in this business. He became interested in the grinding of

spectacle lenses, then an important industry in Delft, Holland, where he lived, and did a great deal of experimental work in this line, mainly for his own enjoyment. Finally he succeeded in making a lens so powerful that he could see in water and various infusions very minute living bodies never before observed. Leeuwenhoek contributed 112 papers to the Royal Society of Great Britain, the first in 1673, many of them accompanied by such accurate descriptions

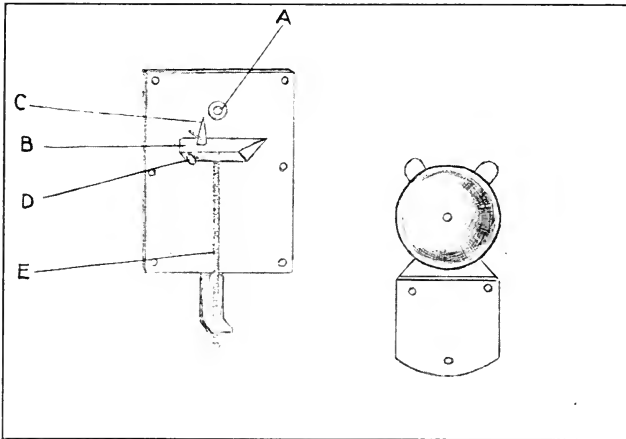

FIG. 169.—Leeuwenhoek's microscope. A is the simple biconvex lens held firmly in place. In front of this is the small table, B, with the support, C, on the tip of which the object to be examined was held. This support could be brought nearer to or removed further away from the lens and held firmly in place by the screw D. E is a second screw for raising or lowering the entire table. A concave mirror that Leeuwenhoek sometimes used to focus more light on the object under examination, is shown at the right.

and drawings, for example a paper submitted September 12, 1683, that there is no doubt that he really saw bacteria and was the first to do so (Fig. 170). Rightly may he be styled "The Father of Bacteriology," if not of the microscope. He says in one paper, "With the greatest astonishment I observed that everywhere through the material I was examining were distributed *animalcules* of the most microscopic dimness which moved themselves about in a remark-



ably energetic way." Thus he considered these living objects to be animals, from their motion, and this belief held sway for nearly two hundred years.

Leeuwenhoek was a pure observer of facts and made no attempt at speculation, but his discoveries soon started the theorists to discussing the origin of these minute organisms. Most observers, as was probably to be expected, believed that they arose spontaneously. Needham, in 1749, described the development of microorganisms around grains of barley in water. Bonnet, in 1768, suggested that probably Needham's animalcules came from ova in the liquid. The Abbot

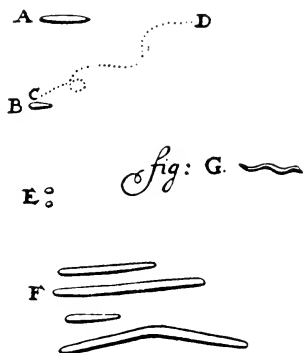

FIG. 170.—The first drawings of bacteria by Leeuwenhoek. The dotted line *C* to *D* indicates the movement of the organism.

Spallanzani, in 1769, called attention to the crudeness of Needham's methods and later, in 1776, attempted to disprove spontaneous origin by heating infusions of organic material in flasks and then *sealing* them. His critics raised the objections that heating the liquids destroyed their ability to support life, and that sealing prevented the access of fresh air which was also necessary. The first objection was disproved by the accidental cracking of some of the flasks which thereafter showed an abundant growth. This accident seemed also to support the second objection, and Spallanzani did not answer it. Though Spallanzani's experiments failed to convince his opponents, they led to important

practical results, since François Appert, in 1810, applied them to the preserving of fruits, meats, etc., and in a sense started the modern canning industry. Spallanzani was the first to boil an infusion to kill the "germs" in it, the first to sterilize purposely by boiling, and the first to seal to keep the germs out.

From Spallanzani to Schultze there were no further experiments to prove or disprove spontaneous generation. Schultze, in 1836, attempted to meet the second objection to Spallanzani's experiment, *i. e.*, the exclusion of air, by

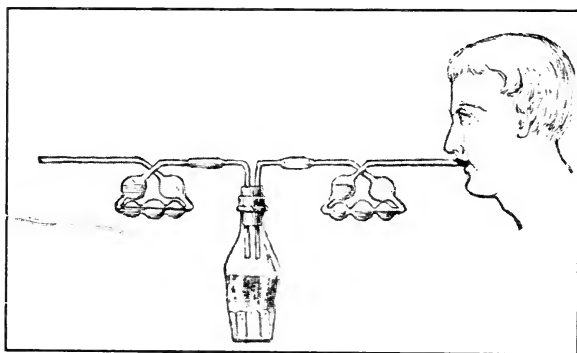

FIG. 171.—Schultze's experiment. The set of bulbs next to the face contained KOH and the other set concentrated  $H_2SO_4$ . Air was drawn through at frequent intervals from May until August, but no growth developed in the boiled infusion.

drawing air through his boiled infusions, first causing it to bubble through concentrated sulphuric acid to kill the "germs" (Fig. 171). His flasks fortunately showed no growths, but his critics claimed that the strong acid changed the properties of the air so that it would not support life. This experiment of Schultze's, though devised for a different purpose, was really the first *experiment* in the use of *chemical disinfectants*, though Thaeer (page 311) had used chemicals in a practical way. Schwann, in 1837, modified this experiment by drawing the air through a tube heated to destroy the living germs (Fig. 172). His experiments were successful,

but the "spontaneous generation" theorists raised the same objection, *i. e.*, the change in the air by heating. This was

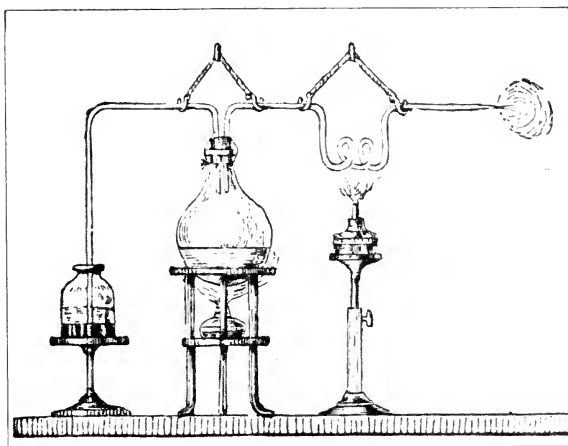

FIG. 172.—Schwann's experiment. After boiling, as shown in the diagram, and cooling, air was drawn into the flask by aspiration while the coiled tube was kept hot with the flame.

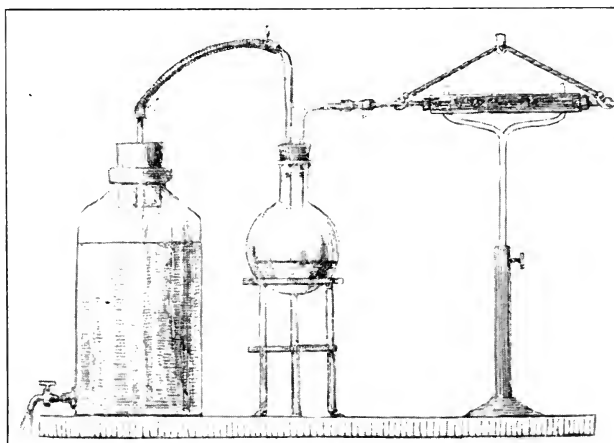

FIG. 173.—Schroeder and Dusch's experiment. The aspirating bottle drew the air through the flask after it had been filtered by the cotton in the tube.

the first *experiment* in which the principle of “*dry heat*” or “*hot air*” sterilization was used. Similar arguments were brought forward, also to the use of *cotton plugs* as filters, by Schroeder and Dusch in 1859 (Fig. 173). This was the first use of the principle of *sterilization by filtration*. It remained for Chevreuil and Pasteur to overcome this objection in 1861 by the use of flasks with long necks drawn out to a point and bent over. These permitted a full access of air by diffusion but kept out living germs, since these cannot fly but are carried mechanically by air currents or fall of their own weight (Fig. 174). Hoffman, the year before (1860), had made similar experiments but these remained unnoticed. The Pasteur flasks convinced most scientists that “spontaneous generation” has never been observed by man, though some few, notably Dr. Charlton Bastian, of England, vigorously supported the theory from the early seventies until his death in November, 1915.

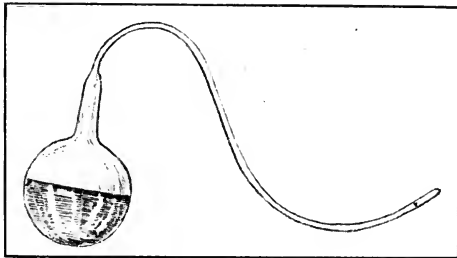

FIG. 174.—Pasteur's flask.

John Tyndall, in combating Bastian's views, showed that boiled infusions left open to the air in a closed box, through which air circulated, did not show any growth of organisms provided the air was so free of particles that the path of a ray of light sent through it from side to side could not be seen (Fig. 175). Or if such sterilized infusions were exposed to dust-free air, as in the high Alps, the majority showed no growth, while all infusions in dusty air did show an abundance of organisms. Tyndall's experiments confirmed those of Pasteur and his predecessors and showed that the organ-

isms developed from "germs" present in the air falling into the liquids and not spontaneously.

While Tyndall's experiments were of great value as indicated, they probably were harmful in another way. These "germs in the air" were considered by bacteriologists as

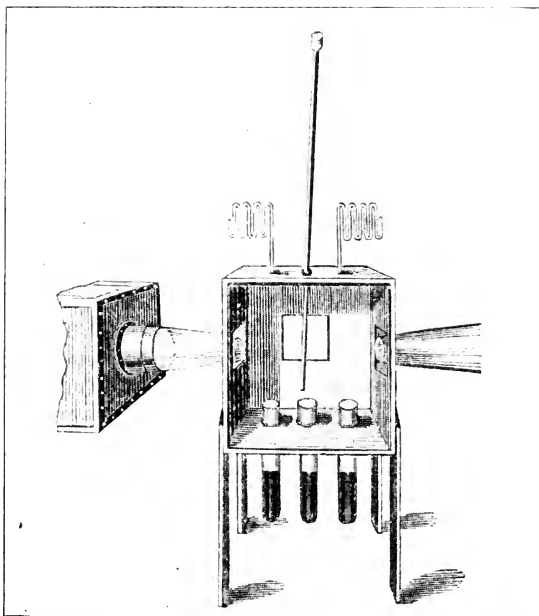

FIG. 175.—Tyndall's box. One side is removed to show the construction. The bent tubes at the top are to permit a free circulation of air into the interior. The window at the back has one corresponding in the front (removed). Through these the beam of light sent through from the lamp at the side was observed. The three tubes received the infusion and were then boiled in an oil bath. The pipette was for filling the tubes. (Popular Science Monthly, April, 1877).

well as laymen to include necessarily many *disease germs* and to indicate the very general, if not universal, presence of these latter *in the air*. This idea led to many erroneous practices in sanitation and disinfection which even to this day are not eliminated.

## CAUSATION OF DISEASE.

The transmission of disease from person to person was recognized by the ancients of European and Asiatic countries. Inoculation of smallpox was practiced in China and India probably several thousand years ago and was introduced by Lady Mary Wortley Montague into England in 1721 from Constantinople. These beliefs and practices do not seem to have been associated with any speculations or theories as to the cause of the disease.

Apparently the first writer on this subject was Varo, about B. C. 70, who suggested that fevers in swampy places were due to invisible organisms. The treatment of wounds during the thirteenth and fourteenth centuries by hot wine fomentations and by the application of plasters was based on the theory that the *air* brought about conditions in the wounds which led to suppuration. These practices were indeed primitive antisepsis, yet were not based on a *germ theory* of the conditions which were partially prevented.

Fracastorius (1484–1553), in a work published in 1546, elaborated a theory of "disease germs" and "direct and indirect contagion" very similar to modern views, though based on no direct pathological knowledge. Nevertheless, Kircher (mentioned already) is usually given undeserved credit for the "contagium vivum" theory. In 1657, by the use of simple lenses, he observed "worms" in decaying substances, in blood and in the pus from bubonic plague patients (probably rouleaux of corpuscles in the blood, certainly not bacteria in any case). Based on these observations and possibly also on reading the work of Fracastorius, his theory of a "living cause" for various diseases was published in 1671, but received little support.

The discoveries of Leeuwenhoek, which proved the existence of microscopic organisms, soon revived the "contagium vivum" idea of Kircher. Nicolas Andry in a work published in 1701 upheld this view. Lancisi in 1718 advanced the idea that "animalcules" were responsible for malaria, a view not proved until Laveran discovered the malarial para-

site in 1880.<sup>1</sup> Physicians ascribed the plague which visited Southern France in 1721 to the same cause, and many even went so far as to attribute all disease to animalcules, which brought the theory into ridicule. Nevertheless the "contagium vivum" theory survived, and even Linnaeus, in his *Systema Naturæ* (1753-1756), recognized it by placing the organisms of Leeuwenhoek, the contagia of diseases and the causes of putrefaction and fermentation in one class called "Chaos."

Plenciz, a prominent physician and professor in the Vienna Medical School, published in 1762 a work in which he gave strong arguments for the "living cause" theory for transmissible diseases. He taught that the agent is evidently transmitted through the air and that there is a certain period of incubation pointing to a multiplication within the body. He also believed that there was a specific agent for each disease. His writings attracted little attention at the time and the "contagium vivum" theory seems to have been almost lost sight of for more than fifty years. Indeed, Oznam, in 1820, said it was no use to waste time in refuting hypotheses as to the animal nature of contagium.

Isolated observers were, however, keeping the idea alive, each in his own locality. In 1787, Wollstein, of Vienna, showed that the pus from horses with glanders could infect other horses if inoculated into the skin. Abilgaard, of Copenhagen, made similar experiments at about the same time. In 1797, Eric Viborg, a pupil of Abilgaard's, published experiments in which he showed the infectious nature not only of the pus but also of the nasal discharges, saliva urine, etc., of glandered horses. Jenner in 1795-1798 introduced vaccination as a method of preventing smallpox. This epoch-making discovery attracted world-wide attention and led to the overcoming of this scourge which had devastated Europe for centuries, but contributed little or nothing to the question of the causation of disease. Prevost's discovery of the cause of grain rust (*Puccinia graminis*) in 1807 was

<sup>1</sup> Sir H. A. Blake has called attention to the fact that the "mosquito theory" of malaria is mentioned in a Sanscrit manuscript of about the sixth century A. D.

the *first instance of an infectious disease of plants* shown to be *due to a microscopic plant organism*, though not a bacterium in this case.

Doubtless one reason why the work on glanders and grain rust attracted little attention among the practitioners of human medicine was owing to the prevalent belief in man's complete separation from all lower forms of life. The evolutionists had not yet paved the way for experimental medicine.

In 1822, Gaspard showed the poisonous nature of material from infected wounds by injecting it into animals and causing their death. Tiedemann (1822) and Peacock (1828) described "little bodies" in the muscles of human cadavers which Hilton (1832) considered to be parasitic in nature. Paget (1835) showed that these bodies were round worms and Owen (1835) described them more accurately and gave the name *Trichina spiralis* to them. Leidy (1846) found organisms in the muscles of hogs which he considered to be the same as Owen's *Trichina* and paved the way for the work of Zenker (1860) in showing the pathological relation between the *Trichina* of pork and human Trichinosis. Bearing on the "contagium vivum" theory was the rediscovery of the "itch mite" (*Sarcoptes scabiei*) by Renucci (1834), an Italian medical student. This had been declared several hundred years before, but had been lost sight of. Chevreuil and Pasteur, in 1836, showed that putrefaction did not occur in meat protected from contamination, and suggested that wound infection probably resulted from entrance of germs from without. Bassi, investigating a disease of silkworms in Italy, demonstrated that a certain mould-like fungus (*Botrytis bassiana*) was the cause in 1837. This was the *first instance of a microscopic vegetable organism* proved to be capable of *causing disease in an animal*.

Boehm, in 1838, observed minute organisms in the stools of cholera patients and conjectured that they might have a causal connection with the disease. Dubini, of Milan, in 1838 discovered the *Ankylostoma duodenale*, which later was further described by Omodei in 1843 and shown to be the cause of Egyptian chlorosis by Griesinger (1851). The



fungous nature of favus, a scalp disease, was recognized by Schönlein in 1839, and the organism was afterward called *Achorion schoenleinii*. Berg, in 1839-1841, showed that thrush is likewise due to a fungus, *Oidium albicans*.

These discoveries led Henle in 1840 to publish a work in which he maintained that all contagious diseases must be due to living organisms, and to propound certain postulates (afterward restated by Koch and now known as "Koch's postulates," page 229) which must be demonstrated before one can be sure that a given organism is the specific cause of a given disease. The methods then in vogue and the instruments of that period did not enable Henle to prove his claims, but he must be given the credit for establishing the "contagium vivum" theory on a good basis and pointing the way for men better equipped to prove its soundness in after years.

In 1842-1843, Gruby showed that herpes tonsurans, a form of ringworm, is due to the fungus *Trichophyton tonsurans*. Klencke, in 1843, produced generalized tuberculosis in a rabbit by injecting tuberculous material into a vein in the ear, but did not carry his researches further. In 1843, Dr. Oliver Wendell Holmes wrote a paper in which he contended that puerperal fever was contagious. Liebert identified the *Peronospora infestans* as the cause of one type of potato rot in 1845. The skin disease pityriasis (tinea) versicolor was shown to be due to the *Microsporon furfur* by Eichstedt in 1846. In 1847, Semmelweiss, of Vienna, recommended disinfection of the hands with chloride of lime by obstetricians because he believed with Holmes in the transmissibility of puerperal fever through poisons carried in this way from the dissecting room, but his theories were ridiculed.

Pollender, in 1849, and Davaine and Rayet, in 1850, independently observed small rod-like bodies in the blood of sheep and cattle which had died of splenic fever (anthrax). That Egyptian chlorosis, afterward identified with Old World "hookworm disease," is caused by the *Ankylostoma duodenale* was shown by Griesinger in 1851. In the same year the *Schistosomum hematobium* was shown to be the

cause of the "Bilharzia disease" by Bilharz. Küchenmeister discovered the tapeworm, *Tænia solium*, in 1852, Cohn, an infectious disease of flies due to a parasitic fungus (*Empusa muscæ*) in 1855, and Zenker showed the connection between trichinosis of pork ("measley pork") and human trichinosis (1860) as indicated above. The organisms just mentioned are, of course, not bacteria, but these discoveries proved conclusively that *living things of one kind or another, some large, most of them microscopic, could cause disease in other organisms* and stimulated the search for other "living contagiums." In 1863, Davaine, already mentioned, showed that anthrax could be transmitted from animal to animal by inoculation of blood, but only if the blood contained the minute rods which he believed to be the cause. Davaine later abandoned this belief because he transmitted the disease with old blood in which he could find no rods. It is now known that this was because the bacilli were in the "spore" form, which Davaine did not recognize. He thus missed the definite proof of the bacterial nature of anthrax because he was not familiar with the life history of the organism, which was worked out by Koch thirteen years later. In 1865, Villemin repeatedly caused tuberculosis in rabbits by subcutaneous injection of tuberculous material and showed that this disease must be infectious also. In the same year Lord Lister introduced antiseptic methods in surgery. He believed that wound infections were due to microorganisms getting in from the air, the surgeon's fingers, etc., and without proving this, he used carbolic acid to kill these germs and prevent the infection. His pioneer experiments made modern surgery possible. In this year also, Pasteur was sent to investigate a disease, Pebrine, which was destroying the silkworms in Southern France. He showed the cause to be a protozoan which had been seen previously by Cornalia and described by Nägeli under the name *Nosema bombycis* and devised preventive measures. This was the *first infectious disease* shown to be *due to a protozoon*. In 1866, Rindfleisch observed small pin-point-like bodies in the heart muscle of persons who had died of wound infection. Klebs, in 1870-1871, published descriptions and

PLATE V

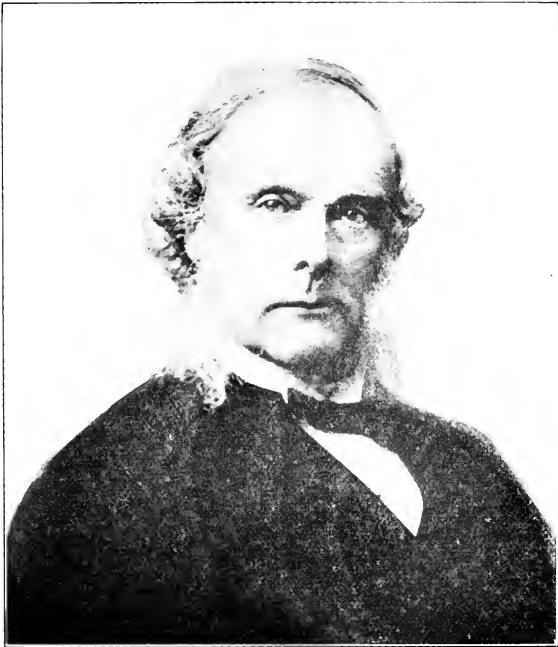

SIR JOSEPH LISTER



PLATE VI



ROBERT KOCH



names of organisms he had found in the material from similar wounds, though he did not establish their causal relation. Bollinger, in 1872, discovered the spores of anthrax and explained the persistence of the disease in certain districts as due to the resistant spores. In 1873, Obermeier observed in the blood of patients suffering from recurrent fever long, flexible spiral organisms which have been named *Spirochæta obermeieri* (more recently *Borrelia recurrentis*). Lösch ascribed tropical dysentery to an ameba, named by him *Amæba coli* (now named *Entamæba histolytica*), in 1875. Finally, Koch, in 1876, isolated the anthrax bacillus, worked out the life history of the organism and reproduced the disease by the injection of pure cultures and recovered the organism from the inoculated animals, thus establishing beyond reasonable doubt its causal relationship to the disease. This was the *first instance of a bacterium* proved to be the cause of a *disease in animals*. Pasteur, working on the disease at the same time, confirmed all of Koch's findings, though his results were published the next year, 1877. Bollinger determined that the *Actinomyces bovis* (*Streptothrix bovis*) is the cause of actinomycosis in cattle in 1877. Woronin in the same year discovered a protozoan (*Plasmodiophora brassicæ*) to be the cause of a disease in cabbage, the *first proved instance of a unicellular animal causing a disease in a plant*. In 1878, Koch published his researches on wound infection in which he showed beyond question that microorganisms are the cause of this condition, though Pasteur in 1837 had suggested the same thing and Lister had acted on the theory in preventing infection.

Burrill at the University of Illinois in the years 1878 to 1881 demonstrated the cause of "fire blight" of apple and pear trees to be due to a bacterium, *the first instance of a plant disease proved to be due to a bacterium*.

These discoveries, especially those of Koch, immediately attracted world-wide attention and stimulated a host of workers, so that within the next ten years most of the bacteria which produce disease in men and animals were isolated and described. It is well to remember that the first *specific* disease of man proved to be caused by a *bacterium* was *tuberculosis* by Koch in 1882.

Progress was greatly assisted by the introduction of anilin dyes as suitable stains for organisms by Weigert in 1877, by Koch's application of special technic and gelatin cultures for isolation and study, 1881, and the great improvements in the microscope by Prof. Abbé, of Jena.

Laveran's discovery of the malarial parasite in 1880 turned attention to protozoa as the causes of disease and led to the discovery of the various piroplasmoses and trypanosomiasis in man and the lower animals.

Pasteur's protective inoculations in chicken cholera and anthrax directed attention to the possibility of using bacteria or their products as a specific protective or curative means against particular diseases. This finally led to the discovery of diphtheria antitoxin by Behring, and independently by Roux, in 1890, a discovery which opened up the wide field of immunity which is so persistently cultivated at the present time.

While the causation of disease by bacteria has probably attracted most attention, especially in the popular mind, it should not be forgotten that this is but one of the numerous ways in which these organisms manifest their activities, and in a sense it is one of their least-important ways, since other kinds are essential in many industries (dairying, agriculture) and processes (sewage purification), and are even *indispensable for the very existence of all green plants and hence of animals, including man himself.*

### PUTREFACTION AND FERMENTATION.

The idea that there is a certain resemblance between some infectious diseases and the processes of putrefaction and fermentation seems to have originated during the discussion on spontaneous generation and the "contagium vivum" theory which followed Leeuwenhoek's discoveries. Plenciz (1762) appears to have first formulated this belief in writing. He considered putrefaction to be due to the "animalcules," and said that it occurred only when there was a coat of organisms on the material and only when they increased and multiplied. Spallanzani's experiments



tended to support this view, since his infusions did not "spoil" when boiled and sealed. Appert's practical application of this idea has been mentioned.

Thaer, in his *Principles of Rational Agriculture*, published in the first quarter of the nineteenth century, expressed the belief that the "blue milk fermentation" was probably due to a kind of fungus that gets in from the air, and stated that he had prevented it by treating the milk cellars and vessels with sulphur fumes or with "oxygenated hydrochloric acid" (hypochlorous acid).

In 1836, Chevreul and Pasteur showed that putrefaction did not occur in meat protected from contamination. In 1837, Caignard-Latour in France and Schwann in Germany independently showed that alcoholic fermentation in beer and wine is due to the growth of a microscopic plant, the yeast, in the fermenting wort. C. J. Fuchs described the organism which is commonly called the "blue milk bacillus" in 1841 and conjectured that the souring of milk was probably bacterial in origin. It remained for Pasteur to prove this in 1857. During the following six or seven years Pasteur also proved that acetic acid fermentation, as in vinegar making, butyric acid fermentation (odor of rancid butter and old cheese) and the ammoniacal fermentation of urea, so noticeable around stables, were each due to different species of bacteria. Pasteur also, during the progress of this work, discovered the class of organisms which can grow in the absence of free oxygen—the anaërobic bacteria. There is no question that Pasteur from 1857 on did more to lay the foundations of the science of bacteriology than any other one man. Influenced by Pasteur's work von Hesselting, in 1866, stated his belief that the process of cheese ripening, like the souring of milk, was associated with the growth of fungi, and Martin also, in 1867, stated that cheese ripening was a process which was akin to alcoholic, lactic and butyric fermentations. Kette, in 1869, asserted the probability of Pasteur's researches furnishing a scientific basis for many processes of change in the soil. In 1873, Schlösing and Müntz showed that nitrification must be due to the action of microorganisms, though the discovery of the particular

ones remained for Winogradsky in 1889. Thus the belief that fermentation and putrefaction are due to microorganisms was as well established by the early eighties of the last century as that similar organisms are the causes of infectious diseases.

### STUDY OF FORMS.

An important part of the scientific knowledge of living organisms is dependent on a study of their forms and relationships. As has been stated, Leeuwenhoek considered bacteria to be "animalcules" because they showed independent movement. But little attention was paid to the natural history of these animalcules for nearly a hundred years after Leeuwenhoek. During the last quarter of the eighteenth century, however, workers busied themselves chiefly with the discovery and description of new forms. Among these students were Baron Gleichen, Jablot, Lesser, Reaumur, Hill and others. Müller, of Copenhagen, in 1786 published the first attempt at classification, a most important step in the study of these organisms: Müller introduced the terms *Monas*, *Proteus* and *Vibrio*, which are still in use. Ehrenberg, in his work on *Infusoria*, or the organisms found in infusions, published in 1838, introduced many generic names in use at present, but still classed the bacteria with protozoa. Joseph Leidy, the American naturalist, considered that the "vibrios" of previous writers were plants and not "animalcules." He seems to have been the first to have made this distinction (1849). Perty (1852) recognized the presence of spores in some of his organisms. Ferdinand Cohn (1854) classed the bacteria among plants. Nägeli (1857) proposed the name "Schizomycetes" or "fission fungi," which is still retained for the entire class of bacteria. Cohn in the years 1872-1875 established classification on a modern basis and added greatly to the knowledge of morphology and natural history of bacteria. He described spore formation and the development of spores into active bacteria, and showed the close relationships as well as differences between the bacteria and the lower algæ. Robert Koch was a pupil of Cohn.

An examination of the accompanying chronological table will show how the investigations and discoveries in connection with "spontaneous generation," the "contagium vivum" theory and putrefaction and fermentation must have been mutually suggestive:

- 1546. Fracastorius, disease germs theory and direct and indirect contagion.
- 1671. Kircher, "contagium vivum" theory.
- 1675. Leeuwenhoek, first saw bacteria, "animalcules."
- 1701. Andry, "animalcules," cause of diseases.
- 1718. Lancisi, "animalcules," cause of malaria.
- 1749. Needham, described development of organisms in water around barley grains.
- 1762. Plenciz, arguments for "living cause" theory and that "animalcules" cause putrefaction.
- 1768. Bonnet, suggested that probably Needham's organisms came from germs in the liquid.
- 1776. Spallanzani, boiled and sealed infusions.
- 1786. Müller, first classified "animalcules."
- 1787. Wollstein, glanders pus infectious.
- 1795-1798. Jenner, vaccination against smallpox.
- 1797. Viborg, transmitted glanders repeatedly.
- 1807. Prevost, grain rust, *Puccinia graminis*. *The first instance of a microscopic plant organism shown to be the cause of a disease in a higher plant.*
- 1810. Appert, directions for "canning."
- 1822. Gaspard, infectiousness of material from wounds.
- 1834. Renucci, itch—itch mite (*Sarcoptes scabiei*).
- 1835. Paget and Owen, *Trichina spiralis*.
- 1836. Schultze, air through acid to kill "germs."
- 1837. Chevreuil and Pasteur, protected meat did not putrefy; suggested wound infection due to entrance of germs from without.
- 1837. Caignard-Latour, Schwann, alcoholic fermentation—yeast.
- 1837. Schwann, air through heated tubes to kill germs.
- 1837. Bassi, muscardine of silkworms, *Botrytis bassiana*. *The first instance of a microscopic plant organism shown to be the cause of a disease in an animal.*

1838. Boehm, cholera, saw organisms in stools (not the cause).
1838. Dubini, discovered *Ankylostoma duodenale*.
1838. Ehrenberg, study of forms.
1839. Schönlein, Favus, *Achorion schoenleinii*.
- 1839–1841. Berg, Thrush, *Oidium albicans*.
1840. Henle, theory of contagious diseases.
1841. Fuchs, bacterial cause of blue milk.
- 1842–1843. Gruby, Herpes tonsurans, *Trichophyton tonsurans*.
1843. Klencke, inoculations of tuberculous material into rabbit.
1843. Holmes, puerperal fever contagious.
1845. Liebert, a potato rot, *Peronospora infestans*.
1846. Leidy, Joseph (American Naturalist), *Trichina spiralis* in pork.
1846. Eichstedt, Pityriasis versicolor, *Microsporon furfur*.
1847. Semmelweiss, recommended disinfection to prevent puerperal fever. Not followed.
1849. Leidy, considered "vibrios" to be plants.
1849. Pollender, Anthrax, saw rods in blood.
1850. Davaine and Rayer, Anthrax, saw rods in blood.
1851. Griesinger, Egyptian chlorosis, *Ankylostoma duodenale*.
1851. Bilharz, Bilharzia disease, *Schistosomum hematobium*.
1852. Kückenmeister, tapeworm, *Tænia solium*.
1852. Perty, saw spores in bacteria.
1854. Cohn, classed bacteria as plants.
1855. Cohn, disease of flies, *Empusa muscæ*.
1857. Nägeli, named bacteria, Schizomycetes.
1857. Pasteur, lactic, acetic, butyric acid fermentation.
1860. Zenker, Trichinosis, *Trichinella spiralis*.
1861. Pasteur, disproof of spontaneous generation.
1863. Davaine, transmitted anthrax by blood injection.
1865. Pasteur, Pebrine of silkworms, *Nosema bombycis*.  
*The first instance of a protozoan shown to be the cause of a disease in a higher animal.*
1865. Villemin, repeatedly transmitted tuberculosis to rabbits.

1865. Lister, introduced antiseptis in surgery.
1866. Rindfleisch, Pyemia, organisms in the pus.
1866. Von Hesselting, cheese ripening.
1867. De Martin, cheese ripening akin to alcoholic fermentation.
1869. Kette, Pasteur's researches a scientific basis for many processes in the soil.
1871. Klebs, Pyemia, organisms in the pus.
1872. Bollinger, spores in anthrax.
- 1872-1875. Cohn, definite classification.
1873. Obermeier, recurrent fever, *Spirochæta obermeieri*.
1873. Schlösing and Münz, nitrification due to organisms.
1875. Lösch, amebic dysentery, *Amæba coli*.
- 1875-1876. Tyndall, germs in the air.
1876. Robert Koch, anthrax, *Bacillus anthracis*. *The first instance of a bacterium shown to be the cause of disease in an animal.*
1877. Bollinger, actinomycosis, *Actinomyces bovis* (*Streptothrix bovis*).
1877. Weigert, used anilin dyes for staining.
1877. Woronin, cabbage disease, *Plasmodiophora brassicæ*. *The first instance of a protozoon shown to be the cause of a disease in a plant.*
1878. Koch, wound infections, bacterial in origin.
- 1878-1881. Burrill, bacterial cause of "fire blight."
1881. Koch, gelatin plate cultures, Abbé, improvements in the microscope.



LIST OF LABORATORY EXERCISES GIVEN IN CONNECTION WITH  
THE CLASS WORK INCLUDED IN THIS TEXT-BOOK.

- Exercise 1. Cleaning glassware.
- Exercise 2. Slides showing relationships.
- Exercise 3. Slides showing cell structures.
- Exercise 4. Slides for cell forms and groupings.
- Exercise 5. Preparation of broth medium from meat juice.
- Exercise 6. Preparation of gelatin from broth.
- Exercise 7. Preparation of agar medium from broth.
- Exercise 8. Potato media.
- Exercise 9. Milk tubes.
- Exercise 10. Sugar broths.
- Exercise 11. Blood serum tubes.
- Exercise 12. Inoculation of tubes. Making of plate cultures.
- Exercise 13. Chromogenesis: Illustrates nicely variation with environment.
- Exercise 14. Thermal death-point.
- Exercise 15. Action of sunlight.
- Exercise 16. Acid and gas from carbohydrates.
- Exercise 17. Action on certain proteins.
- Exercise 18. Production of indol.
- Exercise 19. Reduction of nitrates.
- Exercise 20. Enzyme production.
- Exercise 21. Action of disinfectants.
- Exercise 22. Hanging-drop slides.
- Exercise 23. Staining, introductory.
- Exercise 24. Staining for cell forms and cell groupings.
- Exercise 25. Staining of spores.
- Exercise 26. Staining of acid-fast bacteria.
- Exercise 27. Staining of capsules.
- Exercise 28. Staining of metachromatic granules.
- Exercise 29. Staining of flagella.
- Exercise 30. Study of species.
- Exercise 31. Preparation of fruit juice agar: Isolation of yeasts.
- Exercise 32. Study of yeasts and molds.
- Exercise 33. Study of yeasts and molds.
- Exercise 34. Plating of water.
- Exercise 35. Plating of milk.

# INDEX.

## A

- ABBÉ, 296  
condenser, 197  
microscope, improvements in,  
310, 315
- ABILGAARD, 305
- Abortion agglutinin, 261  
contagious, 244, 264, 274
- Abrin, 114, 258
- Abrus precatorius*, 114
- Abscesses, 239
- Absence of receptors, 294
- Absorption of free nitrogen, 103  
tests, 263
- Accessory substances, growth, 77
- Accidental carriers, 233, 235, 236,  
237  
structures, 27
- Acetic acid, 84  
bacteria, carbon oxidation, 100  
fermentation, 311, 314
- Acetobacter*, 47  
*acidi oxalici*, 63  
*xylinum*, 63
- Acetone, 86
- Achorion schoenleinii*, 307, 314
- Acid, acetic, 84  
fermentation, 311, 314  
agglutination, 262  
amino, relation to green plants,  
106  
butyric, 84  
fermentation, 311, 314  
carbolic, disinfectant action of,  
145  
first used, 308  
fast bacteria, fat content, 64, 65  
stains of, 201, 206  
fermentation, 78  
acetic acid, 84, 311, 314
- Acid, fermentation, Bulgarian fer-  
mented milk, 83  
butyric, 84, 311, 314  
ensilage, 83  
industrial uses, 82, 83  
lactic acid, 82, 83, 84, 311, 314  
sauerkraut, 83  
free, 161  
hydrochloric, 242  
per cent of, 160  
production of, 96  
soils, 61
- Acids, as disinfectants, 144
- Acquired immunity, 247, 248
- Actinobacillus*, 48
- Actinomyces*, 48  
*bovis*, 309, 315
- Actinomycetaceæ*, 46, 48
- ACTINOMYCETALES, 45, 46, 48
- Actinomycosis, cause of, 309, 315  
path of entrance of, 240
- Action of chemical agents, 142  
stains, 201  
reducing, 99
- Activating enzymes, 111
- Active immunity, definition of,  
247, 248  
production of, 248
- Activities of bacteria, biochemical,  
78  
importance of, 310  
physiological, definition of, 68,  
78  
in identification, 213  
overproduction, of cells, 254
- Acute coryza, 240  
disease, 229
- Adulteration of food, anaphylactic  
test in detecting, 293  
complement-fixation test in,  
277

- Adulteration of food, immunity reactions in, 251  
 precipitin test in, 265
- Aëdes, 238
- Aërated sludge, 102
- Aërobes, facultative, 56  
 strict, 56
- Aërobic, 56, 212
- Agar, composition of, 175  
 gelatinizing temperature, 176  
 medium, preparation of, 176  
 melting point of, 175  
 plating in, 185  
 sterilization of, 176
- Agents, chemical, for disinfection, 142-148  
 choice of, for disinfection, 149  
 physical, for disinfection, 117
- Agglutinating group, 262
- Agglutination, 261  
 acid, 262  
 diagnostic value of, 262, 263, 264  
 in identification of bacteria, 263, 264  
 macroscopic, 261  
 microscopic, 261  
 phenomenon, 261
- Agglutinin, 261  
 abortion, 261  
 absorption test for, 263  
 action of, 262  
 anti-, 266  
 antigenic action of, 266  
 bacterial, 261  
 chief, 263  
 co-, 263  
 function of, 262  
 glanders, 261  
 hem-, 261  
 normal, 262  
 partial, 263  
 relation to precipitins, 265  
 specificity of, 263  
 theory of formation, 261  
 typhoid, 261  
 use of, 262
- Agglutinogen, 262
- Agglutinoid, 266
- Aggressins, 287
- Aids to isolation, 195
- Air, bacteria in, 49  
 filtration of, 139
- Air, "germ free," 139
- Albumin in bacteria, 64
- Alcaligenes abortus*, 261
- Alcohol, antiseptic, 146  
 butyl, 86  
 disinfectant, 146  
 oxidation of, 100  
 production of, by bacteria, 96  
 by yeasts, 85, 86
- Alcoholase, 110, 111
- Alcoholic fermentation, 85, 311, 313
- Aldehydes, production of, 96
- Alexin, 267, 269
- Alge, relation to bacteria, 18, 19
- Alimentary tract as path of entrance, 242
- Alkali, per cent of, 160
- Alkalies as disinfectants, 144
- Allergic, 289
- Allergie, 289
- Allergy, 289
- Aluminum, 62
- Amboceptor, 269  
 anti-, 272  
 anticomplementophil, 272  
 anticytophil, 272  
 chief, 270  
 co-, 270  
 in cobra, 272  
 formation of, 269  
 hemolytic, 275  
 partial, 270  
 in rattlesnake, 272  
 specificity of, 270, 274  
 theory of formation, 269  
 test, "unknown," 274
- Amboceptorogen, 270
- Ameba, 309
- Amebic dysentery, 309, 315
- Ameboid cells, 243  
 colonies, 221
- Amino-acids, formation of, by bacteria, 92  
 relation to green plants, 106
- Ammonia, formation of, 90, 93  
 oxidation of, 92, 95, 100  
 reduction to, 99  
 structural formula, 90
- Ammoniacal fermentation, 311
- Amæba coli*, 309, 315
- Amphitrichic, 30



- Amylase, 110  
 Anaërobes, 56  
   cultivation, methods of, 185  
   principles underlying, 185  
   energy, source of, 69  
   facultative, 56  
   isolation of, 187  
   oxygen pressure, 57  
   relation to elements, 66  
 Anaërobic bacteria, 56, 311  
   molecular respiration, 69  
   fermentation, butyric acid, 84  
   lactic acid, 83  
   of polysaccharides, 79  
 Analysis of ash, 62  
   chemical, of tubercle bacilli, 65  
 Anaphylactic, anti-, 289  
   immunity, 289  
   phenomena, 292  
   reaction, uses of, 293  
 Anaphylatoxin, 289  
 Anaphylaxis, 288  
   anti-, explanation of, 289  
   antibodies in, 290  
   incubation period, 289  
   specificity of, 289  
   theory of, 290  
 ANAXIMANDER, 297  
 ANDERSON, 288  
 ANDERSON and McCLINTIC, phenol  
   coefficient, 150, 151  
 ANDRY, NICOLAS, 304, 313  
 Anilin dyes, as antiseptic, 148  
   as disinfectant, 148  
   introduction of, 296, 310, 315  
   as stains, 202  
   selective action of, 196  
   stock solutions of, 202  
   Weigert, 296, 310, 315  
   fuchsin, 202  
   gentian violet, 202  
   water, 203  
 Animalcules, 298  
 Animals as carriers, accidental,  
   233, 237  
   necessary intermediate hosts,  
   233, 238  
   disinfection of, 155  
   energy relationships, 23  
   experimental, 224  
   food relationships of, 23  
   inoculation of, 224  
 Animals, inoculation of, uses of,  
   224  
   resemblances to, 23  
   securing material for examina-  
   tion, 225  
   transporting material for exam-  
   ination, 225  
*Ankylostoma duodenale*, discovery  
   of, 307, 314  
   Egyptian chlorosis, cause of,  
   307, 314  
   hookworm disease, cause of,  
   307  
 Anthrax, 296, 307, 314, 315  
   bacterium, a facultative sapro-  
   phyte, 234  
   isolation of, 309, 315  
   due to a bacterium, 309  
   immunity to, 247  
   path of elimination, 244  
   of entrance, 239, 241, 242  
   persistence due to spores, 309  
   protective inoculation, 310  
   spores, 309, 315  
   transmission, first, 308, 314  
   by flies, 238  
   to human beings, 234  
   vaccine, 250  
 Antiagglutinins, 266  
 Antiaggressins, 287  
 Antiamboceptors, 272  
   antisera in snake poisoning, 272  
 Antianaphylactic, 289  
 Antianaphylaxis, due to intracellu-  
   lar digestion, 291  
   protein immunity compared to,  
   291  
 Antibacterial immunity, 251  
 Antibodies, 255  
   and antigens, tabulation of, 294  
   place of production, 295  
 Antibody, action of, 256  
   chemical composition of, 256  
   definition of, 255  
   formation of, 115, 256  
   function of, 255  
 Anticomplement, 271  
 Anticomplementophil amboceptor,  
   272  
 Anticytophil amboceptor, 272  
 Antidiphtheritic serum, 260  
 Antienzyme, 109, 258

- Antienzyme, function of, 258  
 Antigen, 255  
   chemical composition of, 256  
   definition of, 256  
   in complement-fixation, 256, 274, 275, 276  
   syphilitic, 256, 274  
   in Wassermann test, 276  
 Antigens and antibodies, tabulation of, 294  
   fats and fatty acids as, 256  
   in preparation of a vaccine, 284  
 Antimeningococcus serum, 273  
 Antipollenin, 259  
 Antiprecipitins, 266  
 Antisepsis, 117  
   Lister introduced, 308, 314  
   primitive, 304  
 Antiseptic, 117  
   action of anilin dyes, 148  
   carbolic acid, 145  
   cold, 134  
   formaldehyde, 146  
   osmotic pressure, 135  
 Antisera in snake poisoning, 272  
 Antiserum, definition of, 249  
 Antisnake venoms, 272  
 Antitetanic serum, 260  
 Antitoxic immunity, 251  
 Antitoxin, 257  
   collection of, 259  
   concentration of, 259, 260  
   diphtheria, 250, 258, 260, 310  
   formation, 113, 257  
   function of, 258  
   preparation of, 259  
   standard, 260  
   tetanus, 260  
   unit of, 260  
 Antitoxins, 257-260  
   as factors in immunity, 294  
   preservatives in, 260  
   specific, 257  
 Antivenin, 259  
 Apes, 224  
 Apparatus of Barber, 193, 194  
 Appearance of growth on culture media, 214  
 APPERT, 300, 311, 313  
 Aqueous gentian violet, 202  
 Arborescent growth, 218  
 ARISTOTLE, 297  
 Arnold steam sterilizer, 120  
 Aromatic compounds, production of, 91, 97  
 Arrak, 86  
 Arsenates, reduction of, 100  
 Arsenites, oxidation of, 102  
 ARTHUS, 288  
   phenomenon, 288  
 Articles, unwashable, disinfection of, 154  
   washable, disinfection of, 154  
 Articular rheumatism, 240  
 Ase, termination of name of enzyme, 110  
 Asepsis, 117  
 Aseptic, 117  
 Ash, analysis of, 62  
 Asiatic cholera, 306, 314  
   moisture requirement, 51  
   outside the body, 234, 235  
   path of elimination, 244  
   of entrance, 242  
   specificity of location, 245  
   transmission of, 238  
 Aspergillus, 21  
 Attenuated, 249  
 Autoclave, air-pressure sterilizer, 124  
   pressure sterilizer, 123  
 Autogenous vaccines, 283  
   in epidemic, 237  
 Autoinfection, 230  
 Autolysis, 112  
   self-digestion, 112  
 Autotrophic, 66  
 Available nitrogen, loss of, 99  
*Azotobacter*, 47, 104  
 AZOBACTEREÆ, 47
- B**
- B. C. G., 250  
 BABES-ERNST corpuscles, 29  
 BACILLACEÆ, 45, 47  
 Bacilli, 38  
   "acid fast," 206  
   butter, 206  
   colon, 244, 284  
   glanders, 241, 245  
   grass, 206  
   influenza, 241

- Bacilli, plague, 241  
 size and shape, 37  
 tubercle, 241  
   chemical analysis of, 65  
 typhoid, 244
- Bacillus, 37, 43, 47  
*anthracis*, 296, 315  
   capsule formation, 28  
   spore staining of, 206  
 blue milk, 311  
 of contagious abortion, 241  
 definition of, 37  
 diphtheria, 29  
 Ducrey's, 241  
 glanders, 46  
*subtilis*, 63  
   cellulose in, 63  
   oxygen requirement, 57  
   spore staining, 206  
 tubercle, 249  
 typhoid, 29
- BACTERIEÆ, 47
- Bacteria, absorption of N by, 103  
 acid fast, 64, 65, 206  
 adaptability, range of, 71  
 aërobic, 56, 212  
 aids in isolation of, 195  
 anaërobic, 56, 311  
   molecular respiration of, 69  
 analysis of ash of, 62  
 anilin dyes, action of, on, 148  
 cause of disease in animals, 309  
   of souring of milk, 311  
 cell forms of, 37  
   groupings of, 40  
   structures of, 25  
 chains of, 19  
 chemical composition of, 18, 61  
 classed as fungi, 312  
   as plants, 312, 314  
 dangerous, relatively few, 50  
 definition of, 24  
 dissemination of, 243  
 distribution of, 49  
 elimination of, 243  
 energy relationships of, 23  
 entrance of, 239  
 environmental conditions for  
   growth, 49  
 first classification of, 312, 313  
   drawings of, 299  
   seen, 298, 313
- Bacteria, food relationships of, 19  
 fossil, 50  
 growth curve of, 74  
 higher thread, 20, 23  
 in feces, 50  
 iron, 66, 70  
 isolation of, 191  
 lactic acid, 82  
 measurement of, 20, 200  
 mechanism of entrance, 243  
 metabolism of, 66  
 methods of study of, 158  
 morphology of, 25  
 motile, 29  
 nitric, 101  
 nitrous, 101  
 nucleus of, 26  
 occurrence of, 49  
 pathogenic outside body, 233  
 phosphorescent, 97  
 position of, 17  
 rate of division of, 71, 72  
   of movement of, 29  
 relation to algæ, 18, 19  
   to animals, 22, 23  
   to elements, 66  
   to gas and oil, 80  
   to molds, 20, 23  
   to phosphate rock, 102  
   to plants, 23  
   to protozoa, 22, 23  
   to soil fertility, 105, 106  
   to sulphur deposits, 102  
   to yeasts, 18, 23  
 reproduction of, 18, 40  
 root tubercle, 66, 67, 95  
 shape of, 37  
 size of, 24  
 soil, function of, 105  
 sources of N for, 70, 95  
 speed of, 29  
 spiral, 37  
 staining of, 201-209  
 study of, 158  
 sulphur, 66, 70  
 surface reactions in, 73  
 thermophil, 53, 103  
 true, 20  
 universal distribution of, 71  
 in urine, 50  
 in vinegar, 84
- BACTERIACEÆ, 45, 47

- Bacterial agglutinin, 261  
 vaccine, 281  
   autogenous, 283  
   commercial, 284  
   dosage of, 285  
   lipo-, 283  
   mixed, 284  
   polyvalent, 284  
   preparation of, 282, 284  
   standardization of, 283  
   stock, 283  
   theory of, 285  
   use of, 285
- Bacterin, 249
- Bacteriocidin, 268
- Bacteriological culture tubes, 181  
 examination, material for, 225  
 microscope, 197, 199
- Bacteriology, pathogenic, definition of, 227  
 reasons for study of, 157  
 as a science, 296, 311
- Bacteriolysin, 268
- Bacteriophage, 278
- Bacterio-purpurin, 98
- Bacteriotropin, 280
- BAIL, 287
- Balloon pipette, 190
- Balsam, mounting in, 205
- BARBER, 249  
 apparatus, 193, 194, 195  
 pipette, 193
- Barnyards, disinfection of, 152
- Baskets, wire, 181, 182
- BASSI, 306, 313  
 silkworm disease, 306, 313
- BASTIAN, 302
- BAUMGARTNER, 252
- Beaded growth, 216
- Bean, castor oil, 258  
 jequirity, 258
- Bed-bugs, 237
- Beds, contact, 102  
 hot, 102, 103
- Beer, pasteurization of, 127, 131
- BEHRING, 310
- BELFANTI, 267
- BERG, 307, 314
- BERGEY, 45
- Berkefeld filter candles, 140
- Bichloride of mercury as disinfectant, 144
- BILHARZ, 308, 314
- Bilharzia disease, 308, 314
- Biochemical activities, 78
- Biological relationships, immunity reactions in, 251
- Bipolar germination, 34
- Bismarck brown as counter stain, 209
- Black-leg as facultative saprophyte, 234  
 immunity to, 247  
 moisture requirements of, 52  
 path of entrance of, 239  
 persistence of, 35  
 vaccine, 250
- Bladder, gall, bacteria in, 244
- Bleaching powder as disinfectant, 144
- Block, comparator, 170
- Blood, collection of, 225  
 cytolytic power of, 268  
 serum, liquid, sterilization of, 179  
   Löffler's, 179  
   medium, preparation of, 178  
   sterilization of, 179  
 test, 265
- Bloodvessels in dissemination of organisms, 243
- Blue, Gabbet's, 203  
 Löffler's, 203  
 methylene, 202  
 milk bacillus, 311  
   cause of, 314  
   fermentation, 311, 314
- BOEHM, 306, 314
- Boiling as disinfectant, 118
- Boils, 231, 236, 239
- BOLLINGER, 309, 315
- BONNET, 299, 313
- BORDET, 267
- Borrelia recurrentis*, 309
- Botrylis bassiana*, 306
- Bottles, pasteurization in, 126, 130, 131  
 staining, 203
- Bougies, 140
- Bouillon, 159
- BOYER, 256
- Bread, salt rising, 81, 82
- Bronchitis, 236
- Bronchopneumonia, 229

- Broth, appearance of growth in,  
 215  
 glycerine, 173  
 meat extract, 172  
 preparation of, 159  
 standardization of, 160  
 sterilization of, 160  
 sugar, 173
- Brownian movement, 31, 200
- Brushes, disinfection of, 154
- Bubonic plague, 234
- BUCHANAN, 45, 74
- BUCHNER, 267
- Budding of yeasts, 19, 22
- Buffer, 165
- Bulgarian fermented milk, 83
- Burning as disinfectant, 118
- Burying as disinfectant, 140
- BÜTSCHLE, 25, 27
- Butter bacilli, staining of, 206  
 rancidity of, 87  
 washing of, 88
- Butyl alcohol, 86
- Butyric acid fermentation, 84, 311,  
 314
- Buzzards as accidental carriers, 238  
 turkey, 238
- C**
- CABBAGE disease, protozoal, 309,  
 315
- Cadaverin, 91
- CAIGNARD-LATOUR, 311, 313
- Calcium hypochlorite as disinfectant, 144  
 oxide, 144
- CALMETTE, 250
- Candles, filter, 139  
 Berkefeld, 140  
 Mandler, 140  
 Pasteur-Chamberland, 140
- Canned goods, food poisoning by,  
 91  
 spoilage of, 35
- Canning, introduced, 300, 313  
 principles involved in, 119
- Capsule, 28  
 of spores, 32  
 staining of, 207
- Carbohydrates in bacterial cell, 64  
 fermentation of, 78-87
- Carbol-fuchsin, 203
- Carbolic acid as antiseptic, 145  
 as disinfectant, 145  
 first used, 308  
 produced by bacteria, 91
- Carbol-xylool, 206
- Carbon cycle, 94  
 dioxide for building purposes,  
 69  
 production of, 79  
 function of, 68, 86  
 metabolism, 68  
 oxidation of, 100  
 in proteins, 91, 92  
 respiratory function of, 68  
 source of, 68, 69  
 uses of, 68, 86
- CARBONE, 267
- Carboxydomonas*, 47
- CARDANO, 297
- Carrier problem, solution of, 235  
 universal, 236
- Carriers, 233, 235  
 accidental, 233, 235, 236, 237  
 carrion eaters as, 237  
 control of, 235  
 intermediate hosts as, 238  
 protective measures against, 235,  
 238  
 universal, 236  
 of unknown organisms, 235
- Cars, stock, disinfection of, 155
- Cases, medico-legal, 265, 293
- Castor oil bean, 258
- Catalase, 111
- Catalytic agent, 109
- Catalyzer, 109
- Cattle, 233
- Causation of disease, 114, 304
- Cell, chief, 263  
 constituents of, 63  
 contents of, 25, 63  
 forms of, 37  
 staining for, 209  
 typical, 37  
 grouping, 40  
 staining for, 209  
 metabolism, 68  
 structures, 25  
 wall, 25  
 composition of, 63
- Cells, chemical stimuli of, 253

- Cells, overproduction activity of, 253, 254  
 receptors of, in immunity, 294  
 specific chemical stimuli in, 253  
 specificity of location in, 245
- Cellular theory of immunity, 252
- Cellulose, definition of, 63  
 fermentation of, 79  
 occurrence of, 63
- Chain, 40, 41
- Change of reaction on sterilization, 171
- Channels of infection, 239  
 alimentary tract, 242  
 conjunctiva, 240  
 external auditory meatus, 240  
 genitalia, 241  
 intestines, 242  
 lungs, 241  
 mouth cavity, 240  
 mucosæ, 240  
 nasal cavity, 240  
 pharynx, 241  
 skin, 239  
 stomach, 242  
 tonsils, 240
- Chaos, 305
- Characteristic cell groupings, 43
- Characteristics, cultural, 115  
 of enzymes, 107  
 of toxins, 113
- CHARRIN, 261
- Chart, descriptive, 214
- CHAUVEAU, 252
- Cheese, eyes in, 81, 82  
 failures, 96  
 Limburger, 87  
 odor of, 85, 87  
 ripening of, 311, 315  
 poisoning, 91  
 Swiss, 81, 82
- Chemical agents as disinfectants, 142  
 action of, 142  
 composition, 18, 61  
 cell wall, 63  
 tubercle bacilli, 65  
 disinfectants, first used, 300  
 elements, 62  
 environment, 61  
 normal solution, 161  
 stimuli, 253, 254, 255
- Chemical, stimuli, specific, 253, 254, 255  
 theory, fundamentals of, 252-256
- Chemotherapy, 245, 251
- CHEVREUIL, 302, 311, 313
- Chicken cholera, protective, inoculation, 310  
 pox, 235, 241
- Chief agglutinin, 263  
 cell, 263
- Chitin, 63
- CHLAMYDOBACTERIACEÆ, 48
- CHLAMYDOBACTERIALES, 45, 48
- Chloride of lime as disinfectant, 144  
 mercuric, as disinfectant, 144
- Chlorine as disinfectant, 143
- Chloroform as antiseptic, 148  
 as disinfectant, 148
- Chlorophyl, 18
- Chlorosis, Egyptian, 306, 307, 314
- Choice of agent in disinfection, 149
- Cholera, Asiatic carriers of, 235  
 . accidental, 238  
 . organisms in, 306, 314  
 . facultative saprophytes, 234  
 . path of elimination of, 244  
 . relation to moisture, 51  
 . specific location of, 245  
 . hog, carriers of, 235  
 . accidental, 238  
 . immunity to, 246  
 . path of elimination, 244  
 . serum-simultaneous method in, 249
- Choleras, 242, 244, 245
- Cholesterins as cell constituents, 64
- CHROMOBACTEREÆ, 47
- Chromobacterium*, 47
- Chromogenesis, 98
- Chromoparic, 98
- Chromophoric, 98
- Chronic disease, 229
- Chronological table, 313
- Chymosin, 111
- Circulation of carbon, 94  
 of nitrogen, 94  
 of phosphorus, 94  
 of sulphur, 95
- Classes of enzymes, 110
- Classification, advantage of, 44

- Classification, Bergey's, 45  
 first, 312, 313  
 Müller's, 44, 313  
 S.A.B., 47
- Cleaning of slides, 204
- Clearing of sections, 206
- Closed space disinfection, 146, 147
- Clostridium*, 34, 47  
*acetobutylicum*, 86  
*botulinum*, exotoxin, 114  
 food and forage poisoning, 67, 91  
 poisoning due to toxin, 114  
 as saprophyte, 234  
 specificity of antitoxin, 257, 259
- pasteurianum*, 104
- tetani*, antitoxin, specificity of, 259  
 exotoxin production, 114  
 as saprophyte, 234  
 specific action of, 229
- Clothing, for disinfection, 155
- Coagglutinins, 263
- Coagulases, 111
- Coagulating enzymes, 111
- Coagulation temperature of proteins, 35
- Coal, spontaneous heating of, 69
- Coamboceptor, 270
- Cobra, 272
- COCCACEÆ, 45, 47
- Cocci, 37, 38
- Coccus, appearance after division, 37, 41  
 cell form, 37  
 grouping, 41, 42, 43  
 division of, 41
- Coefficient, phenol, of disinfectant, 150
- Coenzymes, 108
- COHN, 44, 308, 312, 314, 315
- Cold as antiseptic, 134  
 incubator, 212  
 storage, 134
- Colds due to universal carriers, 236  
 path of entrance of, 240  
 vaccines in, 237
- Colon bacilli, 244, 284
- Colonies, ameoid, 221  
 definition of, 159  
 effuse, 219, 221
- Colonies, punctiform, 220  
 rhizoid, 219, 220
- Colony, edge of, 221  
 mold, 223
- Color production, 98
- Colorimetric method of standardization, 171  
 of titration, 172
- Colors, standard, 167
- Combs, disinfection of, 154
- Combustion, spontaneous, 103
- Commensals, 67
- Commercial preparation of lactic acid, 84  
 products, why keep, 117  
 vaccines, 284
- COMMERCIAL SOLVENTS CORPORATION, 86
- Common colds, 236
- Communicable diseases, 228
- Comparator block, 170
- Complement, 269, 270  
 fixation test, 273  
 lecithin as, 270  
 relation to enzymes and toxins, 270  
 source of, 274
- Complementoid, 270
- Complementophil haptophore, 269
- Composition, chemical, of bacteria, 61  
 of enzymes, 107  
 related to fungi, 18, 20  
 relation to food, 61  
 of toxins, 112
- Compounds as disinfectants, 144  
 organic, 145
- Concave mirror, 197
- Concentration of antitoxin, 260  
 of hydrogen ions, 161
- Condenser, Abbé, 197
- Conditions affecting development, 50  
 disinfectants, 149  
 environmental, 50  
 existence, 50  
 for spore formation, 36  
 general, for growth, 50  
 maximum, 50  
 minimum, 50  
 optimum, 50
- Congenital immunity, 247

- Conidia, 21, 22  
 Conidiophore, 21, 22  
 Conjunctiva as path of entrance, 240  
 Connecting link, 18, 19  
 Constant temperature apparatus, 210  
 Contact beds, 102  
 Contagion, direct and indirect, 304, 313  
 Contagious abortion, agglutination test, 264  
     complement-fixation test, 274  
     path of elimination, 244  
     of entrance, 241  
     disease, 228  
 Contagium, definition, 228  
     vivum theory, 304, 305, 307, 313  
 Contamination of food by carriers, 237  
 Continuous pasteurization, 127  
 Contrast stains, 202  
 Convalescents, control of, 236  
 CORNALIA, 308  
 Corpuscles, Babes-Ernst, 29  
     red in complement-fixation test, 275  
     malaria in, 245  
 Corrosive sublimate as disinfectant, 144  
*Corynebacterium*, 46, 48  
     *diphtheriæ*, 46  
     antitoxins for, 259  
     in mixed infections, 230  
     specificity of, 229  
     toxin of, 114  
 Coryza, 240  
 Cotton plugs, 181  
     first used, 302  
 Coughing, 244  
 Crateriform liquefaction, 217  
 Cream ripening, 83  
 CREITE, 267  
 Creolin as disinfectant, 146  
 Cultural appearances, 214  
     characteristics, 115  
 Culture, definition of, 157  
     medium, 157  
     appearance of growth on, 214  
     definition of, 157  
     essentials of, 158  
     gelatin, 174, 310  
     Culture medium, inoculation of, 189  
         kinds of, 159  
         liquid, 158  
         methods of using, 181  
         optimum moisture for, 51  
         plating of, 185  
         reaction of, 161  
         selective, 195, 196  
         solid, 158  
         standardization of, 161-172  
         synthetic, 179  
         titration of, 166, 169, 172  
         use of, 158, 159  
     pure, 157, 191  
     tubes, 181, 182  
         deep, 187, 188  
 Cultures, anaërobic, 185-189  
     from blood, 225  
         internal organs, 226  
     mass, 185, 186  
     plate, 178, 185  
         gelatin, 315  
     potato, 183  
     puncture, 182  
     pure, definition of, 157  
         isolation of, 191-196  
     slant, 183  
     slope, 183  
         effuse, 219  
         rhizoid, 219  
         rugose, 219  
         verrucose, 219  
     stab, 182  
 Curled edge, 222  
 Curve, growth, of bacteria, 74  
 Cutaneous inoculation, 225  
 Cycle, carbon, 94  
     nitrogen, 94  
     phosphorus, 94  
     sulphur, 95  
 Cycles, life, of bacteria, 75  
 Cystitis, 231  
 Cytolysin, 268  
 Cytolysins, 267  
 Cytolytic, 268  
     power of blood, 268  
     serums, failure of, 272  
     substances in immunity, 294  
 Cytophil haptophore group, 269  
 Cytoplasm, 25  
 Cytotoxin, 268



## D

- DALLERA, 288  
 Dark-field illumination, 31, 201  
 DAVAINE, 307, 308, 314  
 Death point, thermal, 53  
   determination of, 212  
 Decomposition, how caused, 92, 93  
   importance of, 95  
   of urea, 93  
 Deep culture tubes, 187  
 Deficiency, vitamines, 246  
 Degeneration forms, 39  
 Delousing in typhus, 238  
 DE MARTIN, 315  
 Denitrification, 100  
 Deodorant, 117  
 Description of enzymes, 107  
 Descriptive chart, 214  
 Development, conditions for, 50  
 D'HERELLE, 278  
 Diagnosis, agglutination test in,  
   213  
   anaphylaxis in, 292  
   complement fixation in, 277  
   immunity reactions in, 251  
   material for bacteriological, 225  
   methods of, 251  
   precipitin test in, 265  
   Widal test in, 264  
 Diaphragm, 200  
 Diastase, 110  
 Diffusion of food through cell wall,  
   23  
 Digestion of proteins, 89  
 Dilution method of isolation, 191  
   plates, 191, 192  
 Dimethylamine, 90  
 Diphtheria antitoxin, 250, 310  
   unit of, 259, 260  
   bacilli, granules in, 29  
   involution forms of, 39  
   carriers in, 235  
   immunity to, 250  
   location of, 245  
   as mixed infection, 230  
   path of entrance, 240  
   specific disease, 229  
   toxin, M.L.D., 260  
 Diplobacillus, 40, 43  
*Diplococcus*, 41, 43, 47  
*Diplospirillum*, 40, 43  
 Discharges, 235  
   intestinal, 244  
   nasal, 244  
   urethral, 244  
   vaginal, 244  
 Discontinuous sterilization, 119  
 Disease, acute, 229  
   of animals to man, 228  
   Bilharzia, 307, 314  
   cabbage, 315  
   causation of, 114, 303  
   chronic, 229  
   communicable, 228  
   contagious, 228  
   of flies, 307, 314  
   foot-and-mouth, 240, 244  
   germs, 304, 306, 313  
   hookworm, 307, 314  
   identification of, 263  
   immunity to, factors in, 294  
   infectious, 228, 308  
     first, 305  
   Johne's, 242, 244  
   non-specific, 229  
   protozoal, eradication of, 238  
     transmission of, 240  
   silkworm, 306, 308, 313, 314  
   skin, 239  
   specific, 229, 306, 308  
   transmission, 228, 304, 305  
 Dish, Petri, 177, 178  
 Disinfectant, 117  
   action of anilin dyes, 148  
   closed space, 146, 147  
   conditions affecting, 149  
   dry heat as, 119  
   moist heat as, 119  
   phenol coefficient of, 150  
   standardization of, 150  
   steam as, 120  
 Disinfectants, action of chemical,  
   142  
   factors affecting, 149  
   first experiment in, 300  
 Disinfection, agents in, 116  
   choice of, 149  
   by boiling, 118  
   by burning, 118  
   by burying, 140  
   chemical, 142  
     first, 300  
   definition of, 116

- Disinfection, discontinuous, 119  
   by filtration, 139  
   by hot air, 119  
   by light, 131  
   by moist heat, 119  
   physical agents in, 117  
   practical, 151  
   precautions in, 151  
   in puerperal fever, 307, 314  
   by steam, 120  
   of surgeon's hands, 307  
   by tyndallization, 119  
 Dissemination of organisms, 243  
 DISTASO, 26-27  
 Distemper, 235  
 Distilling, sour mash, 83, 84  
 Division, planes of, 41, 42, 43  
   rate of, 72  
   transverse, 18, 41  
 DOBELL, 27  
 Dogs, in rabies transmission, 233  
 DORSET, 64  
 Dosage of vaccines, 285  
 Dose, minimum lethal, 260  
   standard test, 260  
 DOUGLAS, 26, 27, 279  
 Dourine, 241, 244  
 Drum-stick spore, 29  
 Dry heat, 119  
 Drying, 117  
 DUBINI, 306, 314  
 Ducrey's bacillus, 241  
 Dunham's peptone solution, 173  
 DURHAM, 261  
 Dyes, anilin, as antiseptics, 148  
   introduction of, 310, 315  
   as stains, 202  
   stock solution of, 202  
 Dysenteries, path of entrance of, 242  
   of elimination of, 244  
   specific location of, 245  
 Dysentery, amebic, 309, 315  
   carriers of, 238  
   tropical, 309
- E**
- Eberthella*, 47  
   *typhi*, 51  
   agglutinin, 261  
*Eberthella typhi* in phenol coefficient, 151  
   in pneumonia by, 242  
 Ectoplasm, 25, 219  
 Edema, malignant, path of entrance, 239  
   as saprophyte, 233  
 Edge of colony, 222  
 Effuse colony, 219, 221  
   slope culture, 219  
 Egg sensitization, 289  
 Egyptian chlorosis, 306, 307, 314  
 EHRENBERG, 312  
 EHRLICH, 252-254  
 Ehrlich's theory of immunity, 252-256  
 EICHSTEDT, 307, 314  
 Electric milk purifier, 137  
 Electricity, 59, 136  
 Electrolytes, 163  
   non-, 165  
   strong, 163  
   weak, 164, 165  
 Electrolytic method of standardization, 166  
 Elements in bacteria, 62  
   chemical, as disinfectants, 142  
 Elimination of organisms, 243  
   paths of, 243  
*Empusa muscæ*, 308, 314  
 Emulsion, 103  
 Encystment, 19  
 Endoenzymes, 112  
 Endogenous infections, 231  
 Endoplasm, 25  
 Endotoxines, 114  
 Energy relationships, 19  
   transformations, 66-72  
 English sparrows as carriers, 238  
 Ensilage, 83, 84  
*Entamoeba histolytica*, 309  
 Enteritis, 229  
 Entire edge, 222  
 Entrance of organisms, mechanism of, 243  
   paths of, 239  
 Environment, chemical, 61  
   theory, unfavorable, 252  
   variations with, 51  
 Environmental conditions, 50  
 Enzyme, activating, 111  
   in anaphylaxis, 290, 291

- Enzyme, anti-, 258  
 artificial, 107  
 characteristics of, 107  
 classes of, 110  
 co-, 103  
 coagulating, 111  
 composition of, 107  
 conditions affecting, 109  
 description of, 107  
 final test for, 109  
 in immunity, 294  
 naming of, 110  
 oxidizing, 107  
 production of, 107  
 reducing, 111  
 spelling of, 110
- Enzymoid, 258
- Eosin, 206
- Epidemics, 237
- Epitheliolysin, 268
- Equatorial spore, 34  
 germination of, 33
- Equivalent, hydrogen, 161
- Eradication of disease, 234, 238
- ERWINEÆ, 47
- Erwinia*, 47
- Erysipelas, hog, 244
- Erysipelothrix*, 48
- Escherichia*, 47  
*coli* antigens, 256  
 in autoinfections, 231  
 gas formed by, 79  
 oxygen limits for, 57  
 pneumonia by, 242  
 in sugar broths, 173
- Essential structures, 25
- Essentials of good culture medium,  
 158
- Esters, production of, 96
- Ether as disinfectant, 148
- EUBACTERIALES, 45, 47
- Examination of bacteriological ma-  
 terial, 225
- Exanthemata, 244
- Exhaustion in immunity, 247  
 theory of immunity, 252
- Existence, conditions for, 50
- Exoenzymes, 112
- Exogenous infections, 231
- Exotoxins, 114
- Experiment, Pasteur's, 302  
 Schroeder and Dusch's, 300, 301
- Experiment, Schultz's, 300  
 Schwann's, 300, 301  
 Spallanzani's, 299  
 Tyndall's, 302
- Experimental animals, 224  
 inoculation, 224  
 uses of, 224
- External auditory meatus, 240  
 genitalia, 245
- Extracellular enzymes, 112
- Extract broth, 172
- Eyes in cheese, 81, 82
- F**
- FACTORS affecting disinfectants,  
 149  
 immunity, 246, 247  
 in immunity to disease, 294
- Facultative, 56, 212  
 aërobes, 56  
 anaërobes, 56, 189  
 parasites, 67  
 saprophytes, 67, 234
- Failure of cytolytic serums, 272  
 vaccines, 284
- Farcy, 243
- Fat colors, 99  
 splitting enzymes, 110
- Father of bacteriology, 298  
 of microscope, 298
- Fats as antigens, 256  
 occurrence in bacterial cell, 64  
 rancidity of, 87  
 in sewage disposal, 87  
 splitting of, 87
- Favus, 306, 314  
 path of entrance of, 239
- Feces, bacteria in, 50
- Feeding as inoculation method, 225
- FEINBERG, 27
- Ferment, organized, 112  
 unorganized, 112
- Fermentation, 78, 310  
 acid, 79, 81, 82  
 acetic, 83, 84, 311, 314  
 butyric, 84, 311, 314  
 lactic, 82, 84, 314  
 alcoholic, 85, 86, 311, 314  
 ammoniacal, 311  
 anaërobic, 83, 84

- Fermentation, bacterial, 311  
   blue milk, 311, 314  
   of carbohydrates, 78  
   definition of, 78  
   gaseous, 79  
   of carbohydrates, 81  
   of polysaccharids, 79  
   tubes, 181, 183, 187  
   yeast, 84, 311, 313  
 Fermented milk, Bulgarian, 83  
 Fever due to invisible organisms, 304  
   hay, 291, 292  
   Malta, 264  
   puerperal, 307, 314  
   recurrent, 309, 315  
   Rocky Mountain spotted, 238  
   scarlet, children more susceptible to, 247  
   in epidemics, 237  
   path of elimination, 244  
   of entrance, 241  
   primary infection, 230  
   quarantine in, 235  
   Texas, eradication of, 238  
   specific disease, 229  
   trench, 238  
   typhoid, moisture requirement, 51  
   path of elimination, 244  
   pathogenic for human beings, 227  
   primary and secondary disease, 230  
   specific disease, 229  
   typhus, 238  
   yellow, eradication of, 238  
   immunity of negro to, 246  
 Fibrin ferment, 111  
 Filament, 41  
 Filiform growth, 218  
 Film, fixing of, 204  
   preparation of, 204  
 Filter, Berkefeld, 139, 140  
   candles, 140  
   Mandler, 140  
   Pasteur-Chamberland, 140  
   sprinkling, 102  
 Filterable, 230  
   virus, 230  
 Filtration, 138  
   of air, 139  
   Filtration, first experiment in, 300  
   First order, receptors of, 258  
   FISCHER, 26, 29  
   Fission yeasts, 18, 22  
   Fixation test, complement, 273  
   Fixed virus, 249  
   Fixing of film, 204  
   Flagella, 29-31  
   staining of, 207  
   Flash process of pasteurization, 131  
   Flask, toxin, 184, 185  
   Flat mirror, 197  
   Fleas, 237  
   FLEXNER, 272  
   Flies as carriers, 237, 238  
   infectious disease of, 308, 314  
   FLÜGGE, 266  
   Focal infection, 231  
   FODOR, VON, 267  
   Follicular tonsillitis, 240  
   Food adulteration, immunity reactions in, 251  
   precipitin test in, 265  
   of bacteria, 22  
   contamination by carriers, 237  
   poisoning, 67, 91, 234  
   relations, general, 66  
   requirements compared with man, 73, 74  
   spoilage of, 73  
   uses of, 68  
   Foot-and-mouth disease, 240, 244  
   Forage poisoning, 67  
   Foreign body pneumonia, 241  
   Formaldehyde as antiseptic, 147  
   as disinfectant, 146  
   generator, 146, 153, 154, 155  
   Formalin, 146  
   Formation of spores, 32  
   Formol, 146  
   Forms, cell, 37  
   degeneration, 39  
   growth, 40  
   involution, 39  
   study of, 312  
   Fossil bacteria, 50  
   Fox fire, 97  
   Foxes, 237  
   FRACASTORIUS, 304, 313  
   Free acid, 161  
   receptors, 255  
   spores, 32

- Fruiting organs, special, 21  
 FUCHS, 311, 314  
 Fuchsin, 202  
   anilin, 202  
   carbol, 203  
 Function, respiratory, 68  
 Fungi, bacteria as, 18, 23  
 Funnel-shaped liquefaction, 219  
*Fusiformis*, 46, 48
- G**
- GABBET'S blue, 203  
   method of staining, 206  
 Gall-bladder, 244  
 Galvanotaxis, 59  
 Gangrene, gas, 233  
 Gas formation in cheese, 81  
   marsh, 79  
   natural, 80  
   production of, 96  
 Gaseous fermentation, 79  
   anaërobic, 79, 81  
   of carbohydrates, 81  
   of polysaccharids, 79  
 Gasometer, 184  
 GASPARD, 306, 313  
 Gelatin, advantage of, 174  
   clearing of, 174  
   composition of, 174  
   cultures first used, 310  
   plate, 170, 315  
   liquefaction of, 174  
   medium, 174  
   plating of, 170  
   standardization of, 174  
   sterilization of, 175  
 Gemmation, 19  
 General conditions for growth, 49  
   food relationships, 66  
   infections, vaccines in, 285  
 Generation, spontaneous, 299  
 Generic names introduced, 312  
 Genitals, external, path of entrance, 241  
   specific localization on, 245  
 Gentian violet, selective action of, 148  
   stain, anilin, 202  
   aqueous, 202  
 Germ theory of disease, 304  
 German measles, 229, 235  
 Germ free air, 139  
 Germination, bipolar, 34  
   equatorial, 33  
   oblique, 34  
   polar, 33  
   spore, 33  
 Germs, 313  
   in the air, 302, 303, 304  
 GESCHEIDEL, 267  
 Giemsa stain, 27  
 Glanders, acute in man, 229  
   agglutination test for, 264  
   agglutinin, 261  
   anaphylactic reaction in, 292  
   bacilli, 245  
   bacillus, 46  
   complement-fixation test in, 274  
   infectious, 305, 313  
   mallease reaction in, 265  
   mallein test for, 292  
   path of elimination, 242, 243, 244  
     of entrance, 241  
   precipitin test in, 265  
   primary in nose, 240  
   specificity of location in, 265  
   transmission, 233, 234  
 Glands, mammary, as path of elimination, 244  
   of entrance, 239  
   salivary, 244  
   skin, 239  
 GLEICHEN, 312  
 Globulin in bacteria, 63  
 Glycerine broth, 173  
 Glycerinized potato, 178  
 Glycogen as cell constituent, 64  
 Goats, 224  
 Gonococcus, 241  
 Gonorrhœa, 244, 245  
 Good health, 295  
 Grain rust, 305, 314  
 Gram-negative organisms, 148, 205  
 Gram-positive organisms, 148, 205  
 Gram's method of staining, 205  
   solution, 205  
 Granular edge, 222  
 Granules, metachromatic, 29  
   Neisser's, 29  
   polar, 29  
 Granulose in bacteria, 64  
 Grape juice, pasteurization of, 127, 131

- Grass bacilli, 206  
 Green plants, N nutrition of, 105  
 GRIESINGER, 306, 307, 314  
 Group, agglutinating, 262  
   haptophore, 257, 258, 265, 266, 269  
   precipitating, 265, 266  
   toxophore, 257, 269  
   zymophore, 258, 266, 269  
 Groupings, cell, 40  
 Growth of anaërobic organisms, 185  
   accessory substances, 77  
   appearance in media, 214  
   arborescent, 218  
   beaded, 218  
   curve of bacteria, 74  
   filiform, 218  
   forms, 40  
   limitation of, 74  
   papillate, 218  
   villous, 218  
 GRUBER, 261  
 Gruber-Widal test, 264  
 GRUBY, 307, 314  
 GUERIN, 250  
 Gum-like substance in bacteria, 63
- H**
- HAECKEL, 279  
 Hanging drop slide, 198  
 Haptins, 254  
 Haptophore, complementophil, 269  
   cytophil, 269  
   group, 257, 258, 266, 269  
 Harness, disinfection of, 154  
 Hay fever, 291, 292  
 Health, good, 295  
 Heat as disinfectant, 118  
   dry, 119  
   moist, 119  
   due to oxidation, 102  
   production of, 102  
 Heated serum, 267, 274, 275  
 Heating of manure, 102  
 HELLMICH, 64  
 HELMONT, VAN, 297  
 Hemagglutinin, 261  
 Hemicellulose, 63  
 Hemolysin, 268  
 Hentolytic amboceptor, 275  
 Hemorrhagic septicemia, 242  
 HEMOPHILEÆ, 47  
*Hemophilus*, 47  
 HENLE, 229, 306, 314  
 HENRICI, 75  
 HERICOURT, 288  
 Herpes tonsurans, 307, 314  
 HESSELING, VON, 311, 315  
 Heterologous sera, 273  
 Heterotrophic, 66  
 High frequency vibrations, 60  
 Higher bacteria, 24  
   thread bacteria, 22  
 HILL, 312  
 HILTON, 306  
 HOFFMAN, 302  
 Hog cholera, 235, 238, 244, 246, 249  
   serum, 272, 273  
   erysipelas, 244  
 Holders, 129, 134  
 HOLMES, 307, 314  
 Homologous sera, 273  
 Hookworm disease, 307  
 Horses, 233  
 Host, 67  
 Hot air sterilization, 300  
   sterilizer, 118  
   beds, 102, 103  
 Hunger in immunity, 247  
 Hydrochloric acid, 242  
 Hydrogen, function of, 70  
   ion, 161  
   standardization, 161  
   equivalent, 161  
   metabolism, 70  
   oxidation, 100  
   peroxide, 143  
   sulphide, oxidation of, 101  
*Hydrogenomonas*, 47  
 Hydrolytic, 110  
 Hydrophobia, 245  
 Hydrostatic pressure, 59  
 Hygienic laboratory, 150, 260  
 Hypochlorite, 143, 144  
   calcium, 144  
   sodium, 144
- I**
- ICE-CREAM poisoning, 91  
 Identification of bacteria, 213, 214  
   of blood, 265  
   of meat, 265

- Identification of milk, 265  
 Illumination, dark field, 31  
 Immersion oil, 197  
 Immunity, 232  
   acquired, 248  
   active, 248  
   anaphylactic, 291  
   antibacterial, 251  
   antitoxic, 251  
   artificial, 248  
   classification of, 247  
   congenital, 247  
   definition of, 246  
   factors in, 294  
     modifying, 246  
   inherited, 248  
   modified by, 246  
   natural, 248  
   outline of, 246  
   passive, 248  
   problems, 251  
   production of, 249  
   to protein, 291  
   reactions, value of, 251  
   relative, 246  
   summary of, 294  
   theories of, 252  
 Immunized, 264  
 Inactivated, 268, 275  
 Incubation period, 228  
   of anaphylaxis, 289  
 Incubator, 210  
   cold, 210, 212  
   rooms, 210  
 Index, chronological, 313  
   opsonic, 280  
   normal, 280, 281  
   phagocytic, 280  
 Indicator, 166, 168, 275  
 Indol, 91  
 Infection, 228  
   auto-, 230  
   channels of, 239  
   endogenous, 231  
   exogenous, 231  
   focal, 231  
   generalized, 285  
   localized, 285  
   mixed, 230  
   primary, 230  
   secondary, 230  
   treatment of, 284  
   wound, 229, 230, 236,  
     239, 243, 296, 304, 306, 308,  
     309, 313, 315  
 Infectious diseases, 228, 308  
   control of, first, 305  
 Infective organisms, specificity of  
   localization of, 245  
 Infestation, 228  
 Infested, 228  
 Influenza, 230, 235, 237, 242, 244  
   bacillus, 241  
 Infusoria, 312  
 Inhalation, 225  
 Inherited immunity, 248  
 Inoculation of animals, 224  
   uses of, 224  
   of culture media, 189  
   first protective, 310  
   methods of, 224, 225  
   needles, 189  
   of smallpox, 303  
 Insects, 237, 238  
 Instruments, sterilization of, 122,  
   152  
 Intestine, 242, 245  
 Intracardiac, 225  
 Intracellular enzyme, 112  
 Invasion, 228  
 Invertase, 110  
 Involution forms, 39  
 Iodine, 143  
 Iron bacteria, 66  
   functions of, 70  
   metabolism of, 70  
 Irregular forms, 38, 39  
 Isolation, aids to, 195, 196  
   of anaërobes, 172  
   of pure cultures, 191  
   methods, 191-194  
 Itch, 313  
   mite, 306
- J**
- JABLOT, 312  
 Jack o'lanterns, 92  
 Jar, Novy, 188, 189  
 JENNER, 249, 305, 313  
 John's disease, 242, 244
- K**
- KETTE, 311, 315  
 Kidney as path of elimination, 244

Kinases, 111  
 KIRCHER, 297, 304, 313  
 KLEBS, 308, 315  
 KLENCKE, 307, 314  
 KOCH, 229, 267, 296, 307, 308, 309,  
 312, 315  
 Koch's postulates, 229, 307  
 KOHN, 73  
 KRAUS, 264  
 KRUSE, 250  
 KÜCHENMEISTER, 307, 314

## L

LAB, 111  
 Lacrimal canal, 240  
 Lactacidase, 110, 111  
 Lactic acid bacteria, 82  
   fermentation, 82, 83, 314  
 LANCISI, 267  
 LANDOIS, 267  
 LATOUR, 311, 313  
 LAVERAN, 304, 310  
 LACTOBACILLÆ, 47  
*Lactobacillus*, 47  
 Leachings, 154  
 Lecithin as antigen, 270  
   cell constituent, 64  
   complement, 270  
 LEEUWENHOEK, 297, 312, 313  
   microscope, 298  
 Legal cases, medico-, 265, 293  
 Legumes, 103, 104  
 LEIDY, 306, 312, 314  
 LE MOIGNAC, 283  
 Leprosy, 229, 240, 245  
*Leptotrichia*, 48  
 LESSER, 312  
 Lethal dose, 260  
*Leuconostoc*, 47  
 Leukocytes, washing of, 280  
 Lice as carriers, 237  
 LIEBERT, 307, 314  
 Life cycles of bacteria, 75  
 Light, action on bacteria, 54  
   as disinfectant, 134  
   production of, 98  
 Limburger cheese, 87  
 Lime, chloride of, 144  
 Limitation of growth, 74  
 Links, connecting, 18, 20

LINNAEUS, 305  
 Lipase, 110  
 Lipochromes, 99  
 Lipoids as antigens, 270  
 Lipovaccine, 283  
 Liquefaction of blood serum, 89  
   of gelatin, 90, 174  
     crateriform, 219  
     funnel-shaped, 219  
     saccate, 219  
     stratiform, 219  
   of proteins, 89, 90  
 Liquefied, 90  
 Liquid blood serum, 179  
   manure, disinfection of, 154  
   media, 158  
 Liquids, sterilization of, 139  
 LISTER, 308, 315  
 Litmus milk, 174  
 Living bacteria, examination of,  
   198, 200  
   cause theory, 305  
 Lobar pneumonia, 242  
 Localized infections, vaccines in,  
   285  
 Location of organisms, specificity  
   of, 245  
 Lockjaw, 227, 229  
 Locust tree, toxin of, 258  
 Löffler's blood serum, 179  
   blue, 203  
 Loop needles, 190  
 Lophotrichic, 30  
 LÖSCH, 309, 315  
 Louisiana sulphur deposits, 102  
 Lung, 241, 245  
 Lye washes as disinfectants, 145  
 Lymph channels in dissemination,  
   243  
 Lysol as disinfectant, 146

## M

McCLINTOCK, 151  
 McCoy, 146  
 Macrococcus, 37  
 Macroscopic agglutination, 261  
 Malaria, 238, 304, 313  
 Malarial parasite, 245, 304, 310  
 Malignant edema, 233, 239  
 Mallease reaction, 265



- Mallein test, 292  
 Malta fever, 264  
 Mammary glands, 244  
 Mandler filter candles, 140  
 Manure, heating of, 102  
   liquid, disinfection of, 154  
*Margaropus annulatus*, 238  
 Marsh gas, 79  
 MARTIN, 311, 315  
 Mass cultures, 185, 186  
 MASSART, 26  
 Material for bacteriological examination, 225  
 Maximum conditions, 50, 51, 52, 57  
 Measles, 235, 241, 244, 246  
   German, 229, 235  
 Measly pork, 307  
 Measurement of bacteria, 200  
   special unit of, 24  
 Meat broth, 159  
   extract broth, 172  
   identification of, 265  
   juice, 159  
   poisoning, 91  
 Mechanical vibration, 60  
 Mechanism of entrance of organisms, 243  
 Medicated soaps, 146  
 Medico-legal examinations, 265, 277, 293  
 Medium, agar, 175  
   blood serum, 178  
   broth, 158  
   culture, 157  
     essentials of, 158  
   gelatin, 174  
   inoculation of, 189  
   liquid, 158  
   methods of using, 181  
   potato, 176  
   reaction of, 61, 161  
   solid, 158  
   standardization of, 161, 166, 169  
   synthetic, 158, 179  
   titration of, 160, 172  
   use of, 159  
 Meningitis, 235, 240  
 Meningococcus, 240  
 Mercuric chloride, 144  
 Mercury, bichloride of, 144  
 Merismopedia, 42  
 Metabiosis, 90  
 Metabolism, 66  
   bacteria and man compared, 74  
   and fungous plants, 18  
   of carbon, 68  
   of hydrogen, 70  
   of iron, 70  
   of nitrogen, 70  
   of oxygen, 69  
   of phosphorus, 71  
   of sulphur, 70  
   within the cell, 71  
 Metachromatic granules, 27, 28, 29  
   staining of, 209  
 Metastases, 231  
 Metatrophic, 66  
 METCHNIKOFF, 252, 267, 279  
*Methanomonas*, 47  
 Methods, dilution, 191  
   of inoculating animals, 224, 225  
   cultures, 181-190  
   of obtaining pure cultures, 191-196  
   serum-simultaneous, 249  
   of staining, 205-207  
   standard, 214  
   for standardization of disinfectants, 150  
   of media, 160-172  
     colorimetric, 167, 171  
     electrolytic, 166  
     phenolphthalein, 161  
   sterilization, 117-155  
   of using culture media, 181  
 Methylamine, 90  
 Methylene blue, 202  
 Mice, white, 224  
 Microbiology, 227  
 MICROCOCCÆ, 47  
 Micrococcus, 37  
*Micrococcus*, 47  
 Micrometer, 200  
 Micromillimeter, 23  
 Micon, 23  
 Microorganisms, cause of nitrification, 311  
 Microscope, improvements in, 311, 315  
   invention of, 297  
   Leeuwenhoek's, 298  
   use of, 197, 199  
 Microscopic agglutination, 261  
*Microsporion furfur*, 307, 314

- Middle ear infection, 237  
 MİGULA, 26  
 Milk, blue, bacillus of, 311, 314  
   fermentation of, 311  
   Bulgarian fermented, 83  
   digestion of, 89  
   flavors in, 96  
   glands, 239  
   identification of, 265  
   litmus, 174  
   pasteurization of, 125-133  
   as path of elimination, 244  
   preparation of, 173  
   purifier, electric, 137  
   souring of, 311  
   sterilization of, 173  
   tuberculous, 244  
 Minimum conditions, 50, 51, 52, 56  
   lethal dose, 260  
 Mirror, use of, 197  
 Mixed infection, 230  
   vaccine, 284  
 Mixotrophic, 63  
 M.L.D., 260  
 MOHLER, 152  
 Moist heat, 119  
 Moisture, 51  
 Mold colonies, 223  
   spores, 20, 21  
 Molds in alcoholic fermentation, 86  
   in relation to bacteria, 20, 21  
 Molecular respiration, 69  
 Monas, 312  
 Monkeys, 224  
 Monotrichic, 29  
 MONTAGUE, 304  
 Mordants, 201, 208  
 Morphology, 25  
   in identification, 158, 209  
 Mosquitoes and malaria, 238, 304  
 Motile bacteria, 31  
 Motion of bacteria, 29, 32  
   Brownian, 31  
   rate of, 29  
 Mounting in balsam, 205  
 Mouth cavity, 240  
 Movement, rate of, 29  
 Mu, 24  
 Mucor, 20  
 Mucosæ, channels of infection, 240  
 MÜLLER, 44, 312, 313  
 Mumps, 235  
 Municipal disinfection, 155  
 MÜNTZ, 311, 315  
 Muscardine, 306, 313  
 Mutation, 75  
 Mycelia, 20, 223  
 Mycetoza, 17, 23  
 MYCOBACTERIACEÆ, 46, 48  
*Mycobacterium*, 48  
   of Johne's disease, 206  
   *lepræ*, 206  
   *smegmatis*, 206  
   *tuberculosis*, 46, 63, 173, 206  
 Mycoproteid, 63  
 Mycorrhiza, 105  
 MYXOBACTERIALES, 48  
 Myxomycetes, 23
- N**
- NÄGELI, 308, 312, 314  
 Naming of enzymes, 110  
 Nasal cavity, path of entrance, 240  
   discharges, 244  
 Natural gas, 80  
   immunity, 247, 248, 294  
 NEEDHAM, 299, 313  
 Needles, inoculating, 189  
   platinum, 189  
 Negative, Gram, 205  
   phase, 286  
   test, 277  
 NEISSERIEÆ, 47  
*Neisseria*, 47  
 Neisser's granules, 29  
   stain, 208  
 NENCKI, 63  
 Nephrolysin, 268  
 Nerve cells, 245  
 NEUFELD, 280  
 Neurin, 91  
 Neurotoxin, 268  
 Neutral solution, 162  
 NEUVEL, 27  
 Nichrome wire, 190  
 Nitrate broth, 173  
   formers, 70  
   oxidation to, 100  
   reduction of, 99  
   in soil, 101  
 Nitric bacteria, 66, 101, 104  
 Nitrification, 311, 315

Nitrite formers, 70  
 oxidation, 100  
 NITROBACTERIÆ, 47  
*Nitrobacter*, 47  
 Nitrogen, absorption, 103  
 in bacterial cell, 62, 70  
 circulation of, 95, 105  
 cycle, 94  
 fertilizers, 105, 106  
 liberation of, 91, 100  
 metabolism of, 70  
 nutrition of green plants, 105  
*Nitrosomonas*, 47  
 Nitrous bacteria, 66, 101, 104  
 Non-electrolytes, 165  
 Non-pathogenic, 67  
 Non-specific disease, 229  
 Normal agglutinins, 262  
 chemical solution, 161  
 opsonic index, 280, 281  
 serum, 268  
 solution, 161  
*Nosema bombycis*, 308, 314  
 NOVY, 179  
 jar, 188, 189  
 mass cultures, 185, 186  
 Noxious retention theory, 252  
 Nuclein, 27, 64  
 Nucleoprotein, 27  
 Nucleus, 26, 27  
 Nutrition of green plants, 105  
 NUTTAL, 267

## O

OBERMEIER, 309, 315  
 Objective, oil immersion, 197  
 Oblique germination of spore, 34  
 Occurrence of bacteria, 49  
 Official classification, 45  
*Oidium albicans*, 306, 314  
 Oil, essential, for clearing, 206  
 immersion objective, 197  
 paraffin, 187  
 relation of bacteria to, 80  
 OMODEI, 306  
 Opsonic index, 280, 281, 285, 286  
 normal, 280, 281  
 method, 281, 285  
 power, 280  
 Opsonin, 279  
 Opsonins, 279, 280, 294

Optimum conditions, 50  
 Order, receptors of first, 257  
 of second, 261  
 of third, 267  
 Organic acids, 64, 96  
 catalyzers, 109  
 compounds, 145  
 Organisms, dissemination in body,  
 243  
 filterable, 230  
 mechanism of entrance of, 243  
 nitric, 66  
 nitrous, 66  
 pathogenic, elimination of, 243  
 entrance of, 239  
 Organized ferments, 112  
 Origin of antibodies, 294  
 Osmotic pressure, 58, 135, 213  
 Otitis media, 240  
 OTTO, 288  
 Overproduction theory, 253, 254  
 OWEN, 306, 313  
 Oxidation, 100  
 of alcohol, 100  
 of arsenites, 102  
 of carbon, 68, 100  
 of nitrites, 100  
 of sulphide of hydrogen, 101  
 of sulphur, 101  
 Oxidizing enzymes, 111  
 Oxygen, compressed, 57  
 as disinfectant, 142, 143  
 function of, 69  
 limits, 57  
 metabolism, 69  
 nascent, 57, 143  
 relationships, 212  
 requirement, 69  
 source of, 56  
 Oyster sensitization, 291  
 OZNAM, 305  
 Ozone, 57, 136, 143

## P

PANCREAS, 244  
 Papillate, 218  
 PAGET, 306, 313  
 Paraffin oil, 187  
 Parasites, definition of, 67  
 facultative, 67

- Parasites, malarial, 245  
 strict, 67
- PARODKO, 57
- Parrots, 233
- Partial agglutinin, 263  
 amboceptor, 270
- PASTEUR, 250, 252, 282, 296, 301,  
 306, 308, 309, 311, 313, 314  
 treatment, 249
- Pasteur-Chamberland filter can-  
 dles, 140
- Pasteurella*, 47
- PASTEURELLE, 47
- Pasteurization, 125-133  
 continuous, 127  
 flash process, 131
- Pasteur's flask, 190, 302
- Pathogenic, 67  
 bacteria outside body, 233  
 bacteriology, 227, 231  
 definition of, 67, 303  
 organisms, elimination of, 243,  
 244  
 entrance of, 239  
 protozoa, 245  
 relative, 227
- Paths of elimination, 243, 244  
 of entrance, 239
- PEACOCK, 306
- Pebrine, 308, 314
- Pedesis, 31
- Penicillium, 23
- Peptone solution, Dunham's, 173
- Percentage of acid, 160  
 of alkali, 160
- Period of incubation, 228  
 anaphylactic, 289
- Peritonitis, 231
- Peritrichic, 30
- Peronospora infestans*, 307, 314
- PERTY, 312, 314
- Pet animals, 237
- Petri dishes, 177, 178
- Petroleum, 80
- PFEIFFER, 267
- Pfeiffer's phenomenon, 267
- Pfeifferella*, 46, 48
- PH, 162
- Phagocytes, 243
- Phagocytic index, 280
- Phagocytosis, 239, 279, 287, 294  
 theory of, 252
- Pharynx, 241
- Phase, negative, 286  
 positive, 286
- Phenol coefficient, 150, 151  
 as disinfectant, 145  
 production of, 91, 97
- Phenolphthalein, 160  
 standardization to, 160, 165  
 titration to, 160, 167
- Phenomenon, anaphylactic, 291  
 Arthus, 288  
 Pfeiffer's, 267  
 Twort-D'Herelle, 278
- Phosphate reduction, 100  
 rock, 102
- Phosphorescence, 97
- Phosphorus cycle, 94  
 metabolism, 71  
 in proteins, 92
- Photogenesis, 97
- Physical agents for disinfection,  
 117
- Physiological activities, 78-115  
 definition of, 68, 78  
 study of, 213
- Physiology of bacteria, 49-115  
 study of, 210
- Phytotoxins, 114
- Pickling, 84
- Pigeons, 238
- Pigments, 64, 98, 99
- Pimples, 231, 236, 239
- PINOY, 283
- Pipette, Barber, 193
- Pipettes, inoculation, 190
- Piroplasma bigeminum*, 229, 238
- Piroplasm, 245
- Piroplasmoses, 238, 239
- PIRQUET, VON, 288
- Pityriasis versicolor*, 307, 314
- Plague, 233, 234, 241, 242
- Planes of division, 41, 42, 43
- Plants and animals, 17  
 resemblances to, 23
- Plasmodiophora brassicae*, 309, 315
- Plasmolysis, 25, 26
- Plasoptysis, 26
- Plate colonies, study of, 221-223  
 cultures, 178, 185
- Plates, dilution, 191, 192  
 gelatin first used, 315  
 use of, 191

- Platinum needles, 189  
 Plectridium, 35  
 PLENCIZ, 305, 310, 313  
 Plugs, cotton, 181  
 Pneumococci, 236, 284  
 Pneumococcus, 236  
 Pneumonia, 230, 236, 237, 241, 244,  
     247  
     broncho-, 242  
     foreign body, 241  
     lobar, 242  
     vaccination against, 237  
 Poisoning, cheese, 91  
     food, 67  
     forage, 67  
     ice-cream, 91  
     meat, 91  
 Polar germination, 33  
     granules, 29  
 Poliomyelitis, 240  
 POLLENDER, 307, 314  
 Pollens, 292  
 Polysaccharids, fermentation of, 79  
 Polyvalent vaccines, 284  
 Pork, measly, 307  
 Position of bacteria, 17  
     of flagella, 29, 30  
     of spore, 33, 34  
 Positive, Gram-, 205  
     phase, 286  
     test, 277  
 Post partum, 247  
 Postulates, Koch's, 229, 307  
 Potato, acidity of, 178  
     glycerinized, 178  
     media, 176  
     plates, 177, 178  
     rot, 314  
     tubes, 176  
         glycerinized, 176  
 Potentiometer, 166  
 Powder, bleaching, 144  
 Power, opsonic, 280  
 Practical sterilization and disin-  
     fection, 151-155  
 Precipitating group, 266  
 Precipitin, 264, 265  
     test, 265  
 Precipitinogen, 265  
 Precipitinoid, 266  
 Precipitins, 265  
     anti-, 266  
     Preparation of antitoxin, 259  
         of bacterial vaccine, 283  
         of film, 204  
 Preservation of slides, 205  
 Preservative, alcohol as, 146  
     in vaccines, 283  
 Pressure, hydrostatic, 59  
     osmotic, 58, 135  
     oxygen, 56-58  
     steam, 122  
     sterilization, 120-133  
 Prevention of disease, 232, 249,  
     251, 281  
 Preventive vaccination in colds,  
     237  
     in pneumonia, 237  
     in rabies, 249  
     in smallpox, 249, 305, 313  
     in tuberculosis, 250  
     vaccines, autogenous, 284  
     stock, 284  
 PREVOST, 305, 313  
 Primary infection, 230  
 Problems, immunity, 251  
 Process kettle, 123-126  
 Production of acids, 96  
     of alcohols, 85, 86, 96  
     of aldehydes, 96  
     of aromatic compounds, 97  
     of enzymes, 107  
     of esters, 96  
     of gases, 96  
     of heat, 102  
     of pigment, 98  
     of toxins, 112  
 Proenzyme, 107  
 Prophylaxis, 288  
 Protamine in bacteria, 64  
 Protease, 110  
 Protective inoculation, first, 310  
 Protein, 64, 251  
     in bacteria, 63, 64  
     coagulation temperature, 35  
     composition of, 89  
     decomposition of, 91  
     differentiation of, 251  
     foreign, 288  
     identification of, 293  
     immunity, 289  
     putrefaction of, 89  
     split products, 290  
     splitting of, 93

Protein, structure of, 290  
 synthesis of, 99  
*Proteus*, 47  
 Protista, 17  
 Protoautotrophic, 66  
 Protophyta, 17  
 Protoplasm, 25  
 Prototrophic, 66  
 Protozoa, 22, 23, 233, 238  
   cause disease, 308  
   cell wall in, 25  
   in intermediate hosts, 238  
   pathogenic, 245  
   relation to bacteria, 22, 23  
   specificity of localization, 245  
 Protozoal diseases, transmission of, 238  
*Pseudomonas*, 47  
   *aëruqinosa*, 114, 261  
 Ptomaines, 90  
*Puccinia graminis*, 305, 313  
 Puerperal fever, 307, 314  
 Punctiform colonies, 220  
 Puncture cultures, 182  
 Pure culture, 157-191  
 Purification of streams, 51  
   of water, 136  
 Purin bases in bacteria, 64  
 Pus cocci, 51  
   infectious, 306  
   organisms, 308, 315  
 Putrefaction, 89, 310  
   definition of, 89  
   end products, 90  
   of proteins, 89  
   in soil, 93  
 Putrescin, 91  
 Pyemia, 19

## Q

QUARANTINE, 235  
   disinfection, 155  
 Quick lime as disinfectant, 141, 144  
 Quinsy, 240

## R

RABBITS, 224  
 Rabies, bacteriological examination for, 226  
   Pasteur treatment of, 249

Rabies, path of elimination of, 244  
   specificity of localization, 245  
   transmission of, 234  
 Räßiger's method of staining, 207  
 Radiations, 59  
 Radium, 59  
 Rancidity of butter, 87  
 Rashes, serum, 288  
   urticarial, 291  
 Rate of division, 27, 72  
   of movement, 29  
 Rats, 224, 233, 237  
 RAYER, 307, 314  
 Reaction, 161  
   change on sterilization, 171  
   mallease, 265  
   of medium, 61, 161  
   precipitin, 265  
 Reactions, immunity, 251  
   surface of bacteria, 73  
 Reasons for staining, 201  
 REAUMUR, 312  
 Receptors, 253, 254  
   absence of, 294  
   of first order, 257, 258  
   free, 255  
   of second order, 261, 266, 280  
   of third order, 267, 269  
 Recurrent fever, 315  
 Red corpuscles, in complement-fixation test, 275, 276  
   specificity of localization in, 245  
 REDI, 297  
 Reducing actions, 99  
   enzymes, 111  
 Reduction of arsenates, 100  
   of nitrates, 99  
   of sulphates, 100  
 Refrigeration as antiseptic, 134  
 REINKE, 165  
 Relapses, 231  
 Relation to oxygen, 212  
 Relationships of bacteria, 17  
   biological, 251  
   energy, 23  
   general food, 66  
 Relative immunity, 246  
 RENAULT, 50  
 Rennet, 111  
 RENUCCI, 306, 313  
 Reproduction of bacteria, 18

- Resemblances to plants, 23  
 Resistance, 246  
   to disease, 237, 246  
   of spores, 35  
 Respiration, molecular, 74  
 Respiratory function, 68  
 Retarders, 129  
 Rheumatism, 240  
*Rhizobium*, 47  
 Rhizoid colonies, 219, 220  
*Rhizopus nigricans*, 223  
*Rhodococcus*, 47  
 RICHEL, 288  
 Ricin, 114, 258  
*Ricinus communis*, 114  
 RIDEAL, 150  
 Rideal-Walker method, 150  
 RIMPAU, 280  
 RINDFLEISCH, 308, 315  
 Ringworm, 307  
 Ripening of cheese, 311, 315  
   of cream, 83  
 Robin, 114, 258  
*Robinia pseudacacia*, 114  
 Rock phosphate, 102  
 Rocky Mountain spotted fever, 238  
 ROGERS, 261  
 Röntgen rays, 59  
 Room temperature, 210  
 Rooms, disinfection of, 152  
   incubator, 210  
 Root tubercle bacteria, 66, 67, 95  
   tubercles, 104  
 ROSENAU, 288  
 Rot, potato, 314  
 Round worm, 220  
 Roup, 235, 240  
 Roux, 310  
 Rubbing as inoculation, 192  
 Rugose slope cultures, 219  
 Rust, grain, 305, 313  
 RUZICKA, 26
- S**
- SACCATE liquefaction, 219  
 Safranin, 202  
 Saliva, 244  
 Salivary glands, 244  
*Salmonella*, cause of food poisoning,  
   91  
 Saké, 86  
 Salt-rising bread, 81, 82  
 Saprogenic, 89  
 Saprophylic, 90  
 Saprophyte, 67, 233  
*Sarcina*, 42, 43, 47  
   *lutea*, 57  
   *ventriculi*, 63  
*Sarcoptes scabiei*, 306, 313  
 Sauerkraut, 83  
 Scarlet fever, 230, 235, 237, 241,  
   244, 247  
 Scavengers, bacteria as, 95  
 SCHICK, 288  
*Schistosomum hematobium*, 307, 314  
 SCHIZOMYCETES, 45, 312, 314  
 SCHIZOSACCHAROMYCETES, 18, 20  
 SCHLÖSING, 311, 315  
 SCHÖNLEIN, 306, 314  
 SCHROEDER and DUSCH, 300, 301,  
   302  
   experiment, 301  
 SCHULTZE, 300, 313  
   experiment, 300  
 SCHWANN, 300, 301, 311, 313  
   experiment, 301  
 SCHWEINITZ, DE, 64  
 Scope of pathogenic bacteriology,  
   231  
 Sea, bacteria in the, 51, 97  
 Sealing air tight, 299  
 Secondary infection, 230  
 Sections, staining of, 206  
 Selective media, 195, 196  
 Self-limited, 229  
 SEMMELWEISS, 307, 314  
 Sensitization, 289  
 Sensitized animal, 289  
   bacteria, 250  
   vaccine, 250  
 Sensitizing, 250  
 Septicemia hemorrhagica, 242  
 Sero-bacterins, 250  
*Serratia*, 47  
   *marcescens*, O limits for, 57  
   temperature effects, 99  
 Serum, anti-, 249  
   antidiphtheritic, 260  
   antimeningococcal, 272  
   antitetanic, 260  
   heated, 267, 274, 275  
   hog cholera, 272  
   Löffler's, 179

- Serum, rashes, 288  
   sickness, 288, 291  
   simultaneous method, 249  
   therapy, 249  
 Serums, cytolytic, failure of, 272  
 Sewage, disposal of, 87, 102  
   sulphate reduction in, 100  
 Shape of bacteria, 37, 38  
   spore, 34  
 Sickness, serum, 288, 291  
 Side-chain theory, 252  
 Silkworm disease, 308, 314  
 Size of bacteria, 24, 38  
 Skatol, 91  
 Skin, channel of infection, 239  
   diseases, 239  
   glanders, 243  
   lesions, 225  
   pocket, 224  
 Slant cultures, 183  
 Slide, cleaning of, 204  
   hanging drop, 198, 200  
   staining on, 204  
 Slope cultures, 183  
   effuse, 219  
   rhizoid, 219  
   rugose, 219  
   verrucose, 219  
 Sludge tanks, aerated, 102  
 Small intestine, 245  
 Smallpox, 235, 241, 244, 303, 305,  
   313  
   babies, 248  
   inoculation, 303  
   vaccine, 249  
 SMITH, THEOBALD, 288  
 Snake poison, 259, 272  
   venoms, 114  
 Sneezing, 244  
 Soap, 146  
   medicated, 146  
 Society of American Bacteriologists,  
   classification, 45  
   descriptive chart, 214  
   key, 45  
 Sodium hypochlorite, 144  
 Soil, acid, 61  
   bacteria, 49, 105  
   bacteriology, 311, 315  
   enrichment, 103  
   fertility, 106  
   organisms, 53  
 Solid media, 158  
 Solution, chemical normal, 161  
   Dunham's peptone, 173  
   Gram's, 205  
   neutral, 162  
   normal, 161  
   stock, 202  
 Sore throat, 236  
 Sound, 60  
 Sour mash, 83  
 Source of complement, 274  
 Souring, 299, 311, 314  
 Sparrows, English, 238  
 Specific amboceptor, 270, 274, 275  
   antibody, 290  
   chemical stimuli, 253, 254, 255  
   disease, 229, 307, 309  
 Specificity of agglutinins, 263  
   of amboceptor, 270  
   of anaphylaxis, 288, 289  
   of location, 245  
   of opsonins, 280  
   of serum, 263  
 Spermotoxin, 268  
 Spherical form, 37  
 SPIRILLACEÆ, 45, 47  
 Spirilloles, 237, 239  
*Spirillum*, 38, 47  
   *rubrum*, 99  
*Spirochæta obermeieri*, 309, 315  
 Spirochetes, 38, 39, 238  
 Splenic fever, 307  
 Split products of proteins, 290  
 Splitting enzymes, 110  
   of fats, 87  
 Spoilage of canned goods, 35, 56  
 Spoiling of food, 73  
 Spontaneous combustion, 92, 103  
   generation, 296, 303, 313, 314  
   outbreaks of disease, 235  
 Sporangia, 233  
 Sporangiphore, 20  
 Sporangium, 20, 21  
 Spore, 32-36  
   anthrax, 309, 315  
   capsule, 32  
   definition of, 35  
   germination, 33  
 Spores, 27, 32-36, 312, 314  
   cause spoiling of canned goods,  
   35  
   conditions for formation of, 36



- Spores, destroyed by boiling, 119  
 first recognized, 312, 314  
 forms of, 32  
 light on, 54  
 mold, 21, 23, 24  
 in pasteurization, 132  
 position of, 33, 34, 35  
 resistance of, 35  
 shape of, 34  
 staining of, 206  
 two in bacterium, 35
- Sprinkling filters, 102
- Stab cultures, 182
- Stables, disinfection of, 152
- Stain, anilin fuchsin, 202  
 gentian violet, 202  
 aqueous gentian violet, 202  
 Bismarck brown, 209  
 carbol-fuchsin, 203  
 contrast, 202  
 Gabbet's blue, 203  
 Löffler's blue, 203  
 Neisser's, 209
- Stains, action of, 201
- Staining, 115, 201-209  
 acid-fast bacteria, 206  
 bottles, 203  
 capsules, 207  
 cell forms, 209  
 groupings, 209  
 flagella, 207  
 Gram's method, 205  
 metachromatic granules, 209  
 Neisser's method, 209  
 Rübiger's method, 207  
 reasons for, 201  
 sections, 206  
 set, Author's, 203  
 spores, 206  
 Welch's method, 207  
 Ziehl-Neelson method, 207
- Standard antitoxin, 260  
 colors, 171  
 methods, 214  
 test dose, 260  
 toxin, 260
- Standardization, 160, 161, 163, 169  
 colorimetric method, 167, 171  
 of culture media, 160-172  
 of disinfectants, 150  
 H-ion method, 161-172
- Standardization, phenolphthalein  
 method, 160, 165  
 of vaccines, 283
- Staphylococci, 236, 241, 244, 284
- Staphylococcus*, 24, 43, 47
- STARIN, 194
- Steam, 120  
 at air pressure, 120  
 sterilizer, 121  
 streaming, 120  
 under pressure, 122
- Sterigmata, 21
- Sterile, 117
- Sterilization, 116  
 of air, 300  
 in canning, 119  
 change of reaction on, 171  
 definition of, 116  
 discontinuous, 119  
 by filtration, 138, 301  
 first experiment on, by boiling,  
 299  
 by chemicals, 300  
 by dry heat, 300  
 by filtration, 301  
 practical, 151
- Sterilizers, pressure, 122-124  
 steam, 121
- Stimuli, chemical, specific, 253,  
 254, 255
- Stock cars, disinfection of, 155  
 solutions, 202  
 vaccines, 284  
 failure of, 284
- Stomach, 242
- Straight needles, 189
- Stratiform liquefaction, 217, 219
- Strawberry poisoning, 291
- Streak methods of isolation, 193  
 plates, 185
- Streptobacillus*, 40, 41, 43
- STREPTOCOCCÆ, 47
- Streptococci, 236, 284
- Streptococcus*, 41, 43, 241
- Streptococcus*, 47
- Streptosporillum*, 40, 43
- Streptothrix bovis*, 309, 315
- Strict aërobe, 56  
 anaërobe, 56  
 parasite, 67
- Strong electrolytes, 163
- Structures, accidental, 27

- Structures, cell, 25  
 essential, 25
- Study of bacteria, 157, 158  
 of forms, 312  
 of physiological activities, 213  
 of physiology, 210
- Subcutaneous inoculation, 224
- Subdural inoculation, 225
- Subepithelial, 225
- Sublimate, corrosive, 144
- Substances, cytolytic, 294
- Substrate, 110
- Successive existence, 90
- Sugar broth, 173
- Sulphate reduction, 100
- Sulphur bacteria, 66, 70  
 cycle, 95  
 deposits, 102  
 function of, 70  
 metabolism of, 70  
 oxidation of, 101  
 in proteins, 92
- Summary of immunity, 294  
 of Ehrlich's theory, 255
- Sunning, 134
- Surface reactions, 73
- Surgical instruments, 152
- Susceptibility, 231
- Swine, 233
- Swiss cheese, 81, 82
- Symbionts, 67
- Symbiosis, 67, 90
- Symbiotic parasites, 67
- Synthetic media, 158, 179
- Syphilis, 229, 244, 245, 274  
 Wassermann test in, 274, 276
- Syphilitic antigen, 275, 276
- T**
- TABULATION of antigens and antibodies, 293
- Tania solium*, 307, 314
- Tapeworm, 228, 307, 314
- Taxes, 200
- Temperature, 52, 210  
 coagulation, 35  
 conditions, 52  
 effect on growth, 210  
 factor in immunity, 246  
 room, 210
- Test, absorption, 263  
 blood, 265  
 complement fixation, 273  
 dose, 260  
 for enzymes, 109  
 for toxins, 113  
 Gruber-Widal, 264  
 mallein, 292  
 negative, 277  
 positive, 277  
 precipitin, 265  
 tuberculin, 292  
 Wassermann, 275, 276  
 Widal, 265
- Testicle, 245
- Tetanus, 227, 233, 239, 245, 247, 248  
 antitoxin, 248  
 toxin, 113
- Tetracoccus, 42, 43
- Tetrad, 42, 43
- Texas fever, 229, 237
- THAER, 300, 311
- Theories of immunity, 252
- Theory, anaphylaxis (Author's), 290  
 cellular, 252  
 chemical, 252, 253  
 contagious disease, 313  
 contagium vivum, 304, 305, 306, 307, 313  
 Ehrlich's, 252-256  
 exhaustion, 252  
 germ, 304  
 of immunity, 252  
 living cause, 305  
 mosquito, 304  
 noxious retention, 252  
 overproduction, 253, 254  
 phagocytosis, 252  
 side chain, 252  
 spontaneous generation, 296  
 unfavorable environment, 252
- Therapy, serum, 249
- Thermal death point, 53, 212
- Thermophil, 53, 57  
 bacteria, 53, 57, 103
- Thermoregulator, 210
- Thermostat, 210
- THIOBACTERIALES, 45, 48
- Thread, 44
- Throats, sore, 236

- Thrombin, 111  
 Thrush, 240, 306, 314  
 Thunderstorms, 73  
 Ticks, 237  
 TIEDMANN, 306  
 Tinea, 307  
 Tissue contrast stains, 202  
 Titer, 264  
 Titration, 163, 169, 172  
   phenolphthalein, 160, 167  
 Tonsil, 240, 245  
 Tonsillitis, follicular, 240  
 TOUSSANT, 282  
 Toxin, 245  
   diphtheria, 114, 260  
   effect of temperature on, 113  
   final test for, 113  
   flask, 184, 185  
   in food poisoning, 91, 114  
   molecule, 257  
   standard, 260  
   test for, 113  
   tetanus, 245, 260  
 Toxin-antitoxin method, 250  
 Toxins, 245  
   and enzymes compared, 114  
   animal, 114  
   as cell constituents, 64  
   characteristics of, 113  
   composition of, 112  
   endo-, 114  
   exo-, 114  
   of other organisms, 114  
   production of, 112  
   specific localization of, 245  
   specificity of, 113  
   true, 114  
   vegetable, 114  
 Toxoid, 258  
 Toxophore group, 257, 258, 269  
 Tract, alimentary, 242  
 Transmission, accidental carriers  
   in, 237, 238  
   agency of, 228  
   of contagious diseases, 228  
   of disease, 234, 305, 307, 314  
   of glanders, 305, 313  
   of protozoal diseases, 238  
   of tuberculosis, 234, 307, 308, 314  
   universal carriers in, 236, 237  
 Transverse division, 18, 41  
 TRAUBE, 267  
 Treatment for infection, 284  
   Pasteur, 249  
 Trench fever, 238  
*Treponema pallidum*, 240, 276  
 Trichina, 306  
*Trichina spiralis*, 306, 313, 314  
*Trichinella spiralis*, 314  
 Trichinosis, 306, 307, 314  
 Trichophyton, 239  
*Trichophyton tonsurans*, 307, 314  
 Trimethylamine, 90  
 Tropical dysentery, 309  
   lands, 234, 238  
 Tropisms, 200  
 True, bacteria, 20  
   toxins, 114  
 Trypanosomes, 238  
 Trypanosomiasis, 237, 238, 239  
 Tubercle bacilli, 241, 249  
   chemical composition of, 64,  
   65  
 Tubercles, root, 104  
 Tuberculin test, 292  
 Tuberculosis, 229, 230  
   diagnosis of, 292  
   due to bacteria, 309  
   organism, 241  
   elimination of, 244  
   entrance of, 241, 242  
   outside the body, 234  
   preventive inoculation, 250  
   produced experimentally, 307,  
   314  
   proved infectious, 308, 314  
   specificity of location, 245  
 Tuberculous milk, 234  
 Tubes, culture, 181, 182  
   deep, 187, 188  
   fermentation, 181, 183, 187  
   milk, 181, 183  
   Vignal, 186, 187  
 Tularemia, 234  
 Turkey buzzards, 238  
 Two spores in a bacterium, 35  
 Twort, 278  
 Twort-D'Herelle phenomenon, 278  
 TYNDALL, 302, 315  
 Tyndallization, 119  
 Tyndall's box, 303  
   experiment, 302  
 Typhoid agglutinin, 261  
   bacilli, 244

Typhoid bacillus, 29, 234  
 carriers, 235  
 fever, 51, 229, 230, 244, 250, 261,  
 264  
 transmission by flies, 238  
 vaccine, 250  
 Typhus, prevention of, 238  
 Typical cell forms, 37

## U

ULTRAMICROSCOPE, 230  
 Ultramicroscopic organisms, 230  
 Ultraviolet rays, 131  
 Unfavorable environment theory,  
 252  
 Unit of antitoxin, 259, 260  
 of measurement, 24  
 Universal carrier, 236  
 Unorganized ferments, 115  
 Unwashed articles, 154  
 Urea, 93  
 Urease, 111  
 Urethral discharges, 244  
 Urine, bacteria in, 50  
 as path of elimination, 243  
 Urticarial rashes, 291  
 Uschinsky's medium, 180  
 Use of agglutinins, 262, 263  
 of vaccine, 282

## V

VACCINATION in chicken cholera,  
 310  
 negative phase in, 286  
 in pneumonia, 237  
 in smallpox, 249, 305, 313  
 Vaccine, 249  
 age of, 284  
 anthrax, 250  
 antigens in, 282, 284  
 autogenous, 283  
 black-leg, 250  
 deprivation of, 281  
 lipo-, 283  
 mixed, 284  
 polyvalent, 284  
 preservative in, 283  
 sensitized, 270

Vaccine, smallpox, 249  
 standardization of, 283  
 stock, 283, 284  
 Vaccines, bacterial, 281  
 in colds, 237  
 dosage of, 285  
 in epidemics, 237  
 failure of, 284, 285  
 in infections, 285  
 lipo-, 283  
 preparation of, 282, 283  
 standardization of, 282, 283  
 stock, 283  
 failure of, 284  
 theory of, 285  
 use of, 285, 299  
 Vacuoles, 26, 27, 28, 206  
 Vaginal discharges, 244  
 VAN HELMONT, 297  
 Variation with environment, 51  
 VARO, 304  
 VAUGHAN, 290  
 and Novy's mass cultures, 185,  
 186  
 Vegetable toxins, 114  
 Vegetables, forcing of, 103  
 Vehicles, disinfection of, 154  
 Venoms, antisnake, 272  
 Verrucose slope cultures, 219  
 VIBORG, 305, 313  
 Vibration, mechanical, 60  
 Vibrations, high frequency, 60  
 Vibrio, 38, 312, 314  
*Vibrio*, 47  
 Vignal tubes, 186, 187  
 VILLEMEN, 306, 314  
 Villous growth, 216, 218  
 Vinegar, 84, 85, 100, 311  
 Virulence, 231  
 Virus, 230  
 filterable, 230  
 fixed, 249  
 Vitamine deficiency, 246  
 VON PIRQUET, 288  
 Vultures, 237, 238

## W

WALKER, 150  
 Wall, cell, 25  
 composition of, 63

Wall, cell, selective action of, 61  
 WARDEN, 256  
 Washable articles, 154  
 Washing leukocytes, 280  
 Wassermann test, 275, 276  
 Water, anilin, 203  
   bacteria in, 49  
   filtration of, 138, 139  
   percentage of, 62  
   purification of, 57, 136  
   sterilization of, 143  
 Weak electrolytes, 164  
 WEBB, 249  
 WEIGERT, 253, 254, 296, 310, 315  
 Welch's method of staining, 207  
 WELLS, 293  
 Whooping cough, 241, 247  
 WIDAL, 261  
 Will o'the wisp, 92  
 Wine, pasteurization of, 127  
 WINOGRADSKY, 66, 312  
 Wire baskets, 181, 182  
   nichrome, 190  
 WOLLSTEIN, 305, 313  
 WORONIN, 309, 315  
 Wound infections, 229, 230, 236,  
   239, 243, 296, 304, 306, 308, 309,  
   313, 315  
 WRIGHT, 279

## X

X-RAYS, 59  
*Xylinum*, *Acetobacter*, 63

## Y

YEASTS in fermentation, 84, 85,  
   100, 311, 313  
   fission, 18  
   relation to bacteria, 18, 20, 23  
   reproduction of, 19  
 Yellow fever, 238, 246

## Z

ZANZ, HANS, 297  
 ZACHARIAS, 297  
 ZENKER, 306, 307, 314  
 ZETTNOW, 27  
 ZIEMANN, 27  
 Ziehl-Neelson method of staining,  
   207  
 Ziehl's solution, 203  
 Zoöglæa, 28  
 Zoötoxins, 114  
 Zymases, 111  
 Zymogen, 107, 111  
 Zymophore group, 258, 266, 269











